



# basic education

Department:  
Basic Education  
**REPUBLIC OF SOUTH AFRICA**

**NASIONALE  
SENIOR SERTIFIKAAT**

**GRAAD 12**

**FISIESE WETENSKAPPE: CHEMIE (V2)**

**NOVEMBER 2019**

**PUNTE: 150**

**TYD: 3 uur**

**Hierdie vraestel bestaan uit 14 bladsye en 4 gegewensblaaië.**

**INSTRUKSIES EN INLIGTING**

1. Skryf jou sentrumnommer en eksamennommer in die toepaslike ruimtes op die ANTWOORDEBOEK neer.
2. Hierdie vraestel bestaan uit TIEN vrae. Beantwoord AL die vrae in die ANTWOORDEBOEK.
3. Begin ELKE vraag op 'n NUWE bladsy in die ANTWOORDEBOEK.
4. Nommer die antwoorde korrek volgens die nommeringstelsel wat in hierdie vraestel gebruik is.
5. Laat EEN reël oop tussen twee subvrae, bv. tussen VRAAG 2.1 en VRAAG 2.2.
6. Jy mag 'n nieprogrammeerbare sakrekenaar gebruik.
7. Jy mag toepaslike wiskundige instrumente gebruik.
8. Jy word aangeraai om die aangehegte GEGEWENSBLAAIE te gebruik.
9. Toon ALLE formules en vervangings in ALLE berekeninge.
10. Rond jou FINALE numeriese antwoorde tot 'n minimum van TWEE desimale plekke af.
11. Gee kort (bondige) motiverings, besprekings, ens. waar nodig.
12. Skryf netjies en leesbaar.

**VRAAG 1: MEERVOUDIGEKEUSE-VRAE**

Vier opsies word as moontlike antwoorde op die volgende vrae gegee. Kies die antwoord en skryf slegs die letter (A–D) langs die vraagnommers (1.1 tot 1.10) in die ANTWOORDEBOEK neer, bv. 1.11 D.

1.1 Watter EEN van die volgende verbindings het die HOOGSTE dampdruk?

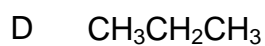
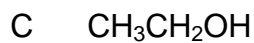
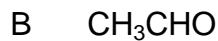

(2)

1.2 Watter EEN van die formules hieronder verteenwoordig die produk van 'n POLIMERISASIE-reaksie?

<b>A</b>	$\begin{array}{c} \text{H} \quad \text{H} \\   \quad   \\ \text{H}-\text{C}-\text{C}-\text{O}-\text{H} \\   \quad   \\ \text{H} \quad \text{H} \end{array}$	<b>B</b>	$\begin{array}{c} \text{H} \\   \\ \text{H}-\text{C}-\text{C}=\text{O} \\   \quad   \\ \text{H} \quad \text{H} \end{array}$
<b>C</b>	$\left[ \begin{array}{c} \text{H} \quad \text{H} \\   \quad   \\ -\text{C}-\text{C}- \\   \quad   \\ \text{H} \quad \text{H} \end{array} \right]_n$	<b>D</b>	$\begin{array}{c} \text{H} \quad \text{H} \quad \text{O} \quad \text{H} \\   \quad   \quad    \quad   \\ \text{H}-\text{C}-\text{C}-\text{O}-\text{C}-\text{C}-\text{H} \\   \quad   \quad \quad \quad   \\ \text{H} \quad \text{H} \quad \quad \quad \text{H} \end{array}$

(2)

1.3 Watter EEN van die volgende kombinasies is BEIDE ONVERSADIGDE KOOLWATERSTOWWE?



(2)

- 1.4 Watter EEN van die volgende stelle waardes vir aktiveringsenergie ( $E_a$ ) en reaksiewarmte ( $\Delta H$ ) is moontlik vir 'n reaksie?

	<b>AKTIVERINGSENERGIE</b> ( $E_a$ ) ( $\text{kJ}\cdot\text{mol}^{-1}$ )	<b>REAKSIEWARMTE</b> ( $\Delta H$ ) ( $\text{kJ}\cdot\text{mol}^{-1}$ )
A	100	+100
B	50	+100
C	50	+50
D	100	-50

(2)

- 1.5 Beskou die volgende gebalanseerde vergelyking vir 'n sisteem in ewewig:

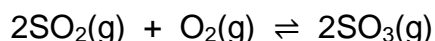

Hoe sal die byvoeging van 'n katalisator by die reaksiemengsel die OPBRENGS en REAKSIETEMPO beïnvloed?

	<b>OPBRENGS</b>	<b>REAKSIETEMPO</b>
A	Toeneem	Toeneem
B	Bly dieselfde	Bly dieselfde
C	Bly dieselfde	Toeneem
D	Afneem	Toeneem

(2)

- 1.6 'n Hipotetiese reaksie bereik ewewig by 'n sekere temperatuur in 'n geslote houer volgens die volgende gebalanseerde vergelyking:

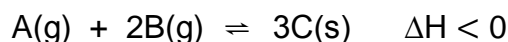

Watter EEN van die volgende veranderinge aan die ewewigtoestande sal tot 'n TOENAME in die ewewigskonstante,  $K_c$  lei?

- A Verhoging in temperatuur
- B Verlaging in temperatuur
- C Toename in druk by konstante temperatuur
- D Afname in druk by konstante temperatuur

(2)

- 1.7 'n Soutsuuroplossing,  $\text{HCl}(\text{aq})$ , en 'n asynsuuroplossing,  $\text{CH}_3\text{COOH}(\text{aq})$ , met GELYKE KONSENTRASIES word vergelyk.

Hoe vergelyk die  $\text{H}_3\text{O}^+(\text{aq})$ -konsentrasie van  $\text{HCl}(\text{aq})$  en die pH van  $\text{HCl}(\text{aq})$  met dié van  $\text{CH}_3\text{COOH}(\text{aq})$ ?

	$[\text{H}_3\text{O}^+]$ van $\text{HCl}(\text{aq})$	pH van $\text{HCl}(\text{aq})$
A	Hoër as	Hoër as
B	Hoër as	Laer as
C	Gelyk aan	Gelyk aan
D	Hoër as	Gelyk aan

(2)

- 1.8 Twee hipotetiese halfreaksies en hulle onderskeie reduksiepotensiale word hieronder getoon:

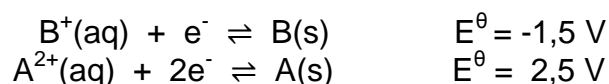

Die stowwe hierbo word gebruik om 'n galvaniese sel op te stel.

Watter EEN van die volgende stellings is KORREK vir hierdie galvaniese sel?

- A B(s) is die reduseermiddel.
- B A(s) is die oksideermiddel.
- C Die massa van B(s) sal toeneem.
- D Die massa van A(s) sal afneem.

(2)

- 1.9 In 'n elektrolitiese sel ...

- A is die anode die positiewe elektrode.
- B vind oksidasie by die katode plaas.
- C vloeie elektrone vanaf die katode na die anode.
- D neem die massa van die anode toe.

(2)

- 1.10 Watter EEN van die volgende word as 'n katalisator in die Ostwaldproses gebruik ?

- A Yster
- B Koper
- C Platinum
- D Vanadium(V)oksied

(2)

**[20]**

**VRAAG 2 (Begin op 'n nuwe bladsy.)**

- 2.1 Die IUPAC-naam van 'n organiese verbinding is 4,4-dimetielpent-2-yn.
- 2.1.1 Skryf die ALGEMENE FORMULE neer van die homoloë reeks waaraan hierdie verbinding behoort. (1)
- 2.1.2 Skryf die STRUKTUURFORMULE van hierdie verbinding neer. (3)
- 2.2 Die organiese verbinding hieronder het een posisionele isomeer en een funksionele isomeer.

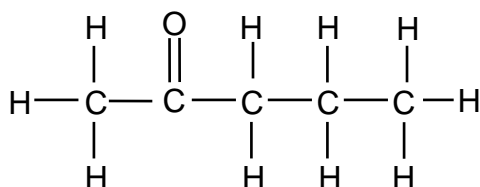

- 2.2.1 Definieer die term *posisionele isomeer*. (2)
- Vir hierdie verbinding, skryf neer die:
- 2.2.2 IUPAC-naam van sy POSISIONELE isomeer (2)
- 2.2.3 Struktuurformule van sy FUNKSIONELE isomeer (2)
- 2.3 Beskou die gekondenseerde struktuurformule van 'n organiese verbinding hieronder.

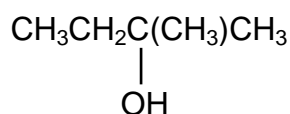

- 2.3.1 Is dit 'n PRIMÊRE, SEKONDÊRE of TERSIÊRE alkohol? Gee 'n rede vir die antwoord. (2)
- 2.3.2 Skryf die IUPAC-naam van die verbinding hierbo neer. (2)
- 2.3.3 Skryf die IUPAC-naam neer van die HOOF ORGANIESE PRODUK gevorm wanneer hierdie verbinding 'n eliminasie reaksie ondergaan. (2)

**[16]**

**VRAAG 3 (Begin op 'n nuwe bladsy.)**

Die kookpunte van vyf organiese verbindings (**P**, **Q**, **R**, **S** en **T**) word bestudeer.

VERBINDING	IUPAC-NAAM
<b>P</b>	Pentanaal
<b>Q</b>	2,2-dimetielbutaan
<b>R</b>	3-metielpentaaan
<b>S</b>	Heksaan
<b>T</b>	Pentan-1-ol

3.1 Definieer die term *kookpunt*. (2)

Die kookpunte van verbindings **Q**, **R** en **S** word vergelyk.

3.2 Gee 'n rede waarom dit 'n regverdige vergelyking is. (1)

Die kookpunte van **Q**, **R** en **S** word hieronder gegee (NIE noodwendig in die korrekte volgorde NIE).

55 °C	49,7 °C	68 °C
-------	---------	-------

3.3 Watter EEN van hierdie drie kookpunte is mees waarskynlik die kookpunt van verbinding **R**? Verduidelik die antwoord. (4)

3.4 'n Mengsel van gelyke hoeveelhede van **P** en **T** word in 'n fles geplaas en verhit tot 'n temperatuur laer as hulle kookpunte. Aanvaar dat geen reaksie of kondensasie plaasvind nie. Die damp wat gevorm word, word in 'n spuit versamel.

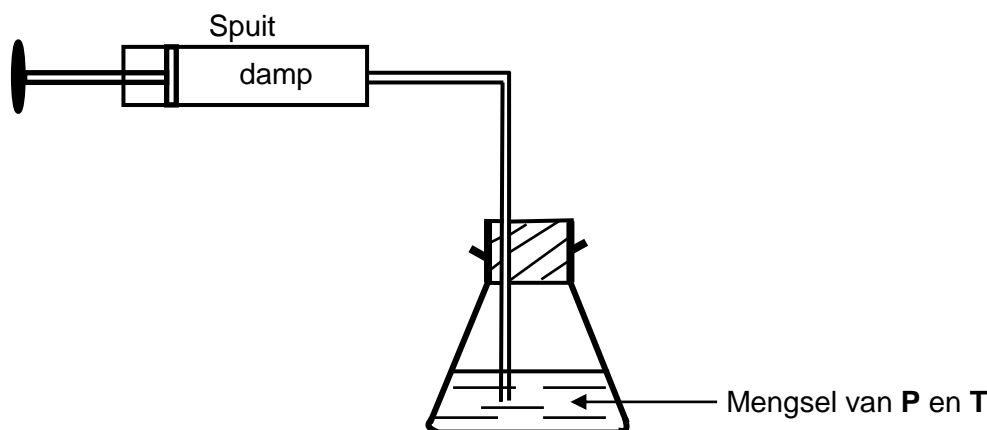

3.4.1 Watter verbinding (**P** of **T**) sal in 'n groter hoeveelheid in die SPUIT teenwoordig wees? (2)

3.4.2 Verduidelik die antwoord op VRAAG 3.4.1 deur na die TIPES en STERKTE van intermolekulêre kragte te verwys. (3)

**VRAAG 4 (Begin op 'n nuwe bladsy.)**

Die vloeiagram hieronder toon hoe verbinding **A** gebruik kan word om ander organiese verbindings te berei. Die nommers **I**, **II**, **III** en **IV** stel verskillende organiese reaksies voor.

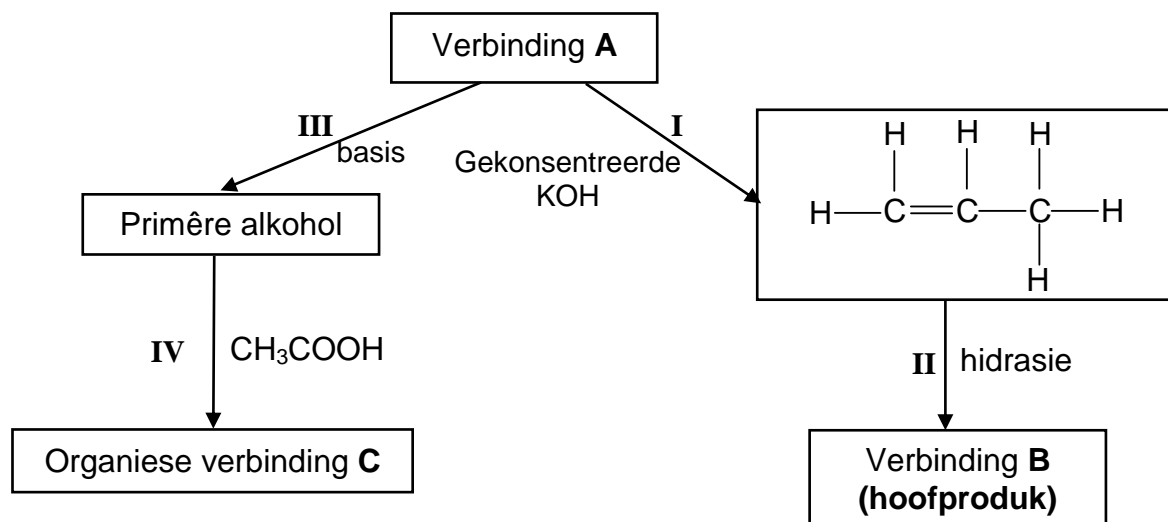

Gebruik die inligting in die vloeiagram om die volgende vrae te beantwoord.

- 4.1 Noem die homoloë reeks waaraan verbinding **A** behoort. (1)
- 4.2 Skryf die TIPE reaksie neer voorgestel deur:
- 4.2.1 **I** (1)
- 4.2.2 **III** (1)
- 4.2.3 **IV** (1)
- 4.3 Beskou **reaksie III**. Skryf neer:
- 4.3.1 TWEE reaksietoestande vir hierdie reaksie (2)
- 4.3.2 Die IUPAC-naam van die primêre alkohol wat gevorm word (2)
- 4.4 Teken die STRUKTUURFORMULE vir verbinding **B**. (2)
- 4.5 Beskou **reaksie IV**. Skryf neer die:
- 4.5.1 Struktuurformule van organiese verbinding **C** (2)
- 4.5.2 NAAM of FORMULE van die katalisator wat gebruik word (1)

**[13]**

**VRAAG 5 (Begin op 'n nuwe bladsy.)**

Die kalsiumkarbonaat ( $\text{CaCO}_3$ ) in teensuurtablette reageer met verdunde soutuur ( $\text{HCl}$ ) volgens die volgende gebalanseerde vergelyking:

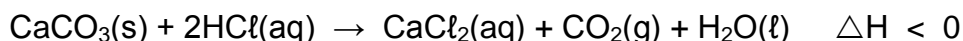

- 5.1 Is die reaksie hierbo EKSOTERMIES of ENDOTERMIES? Gee 'n rede vir die antwoord. (2)

'n Teensuurtablet met massa 2 g word in  $\text{HCl}(\text{aq})$  geplaas. Na 30 s word gevind dat die massa van die tablet 0,25 g is.

- 5.2 Bereken die gemiddelde tempo (in  $\text{g}\cdot\text{s}^{-1}$ ) van die reaksie hierbo. (3)

Die teensuurtablet bevat 40% kalsiumkarbonaat. Nog 'n teensuurtablet met massa 2 g word toegelaat om volledig met  $\text{HCl}(\text{aq})$  te reageer.

- 5.3 Bereken die volume koolstofdoksied,  $\text{CO}_2(\text{g})$  wat by STD versamel sal word. Aanvaar dat al die  $\text{CO}_2(\text{g})$  geproduseer van die kalsiumkarbonaat is. (5)

Die reaksietempo van soortgelyke teensuurtablette met oormaat  $\text{HCl}(\text{aq})$  met 'n konsentrasie van  $0,1 \text{ mol}\cdot\text{dm}^{-3}$  by **VERSKILLENDE TEMPERATURE** word gemeet. Die grafiek hieronder is verkry.

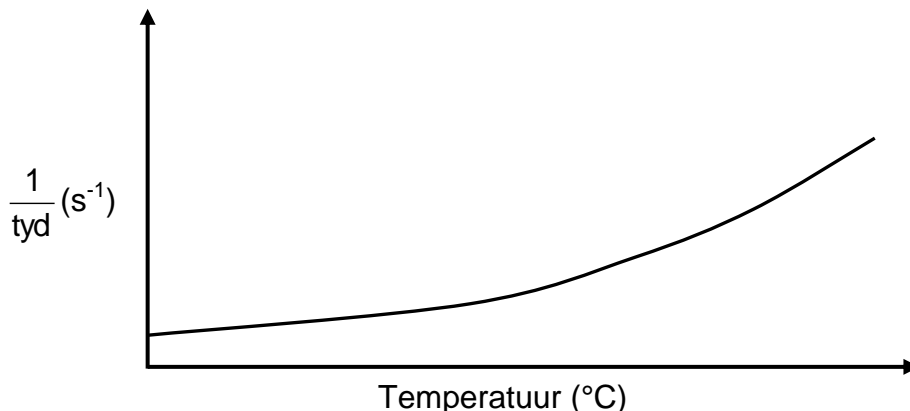

Gebruik die inligting in die grafiek om die volgende vrae te beantwoord.

- 5.4 Skryf EEN gekontroleerde veranderlike vir hierdie ondersoek neer. (1)

- 5.5 Skryf 'n gevolgtrekking neer wat van die grafiek gemaak kan word. (2)

- 5.6 Gebruik die botsingsteorie om die antwoord op VRAAG 5.5 volledig te verduidelik. (3)

- 5.7 Teken die grafiek hierbo in die ANTWOORDEBOEK oor. Op dieselfde assestelsel, skets die kurwe wat verkry sal word indien  $\text{HCl}(\text{aq})$  met 'n konsentrasie van  $0,2 \text{ mol}\cdot\text{dm}^{-3}$  nou gebruik word. Benoem hierdie kurwe Y. (2)

**[18]**

**VRAAG 6 (Begin op 'n nuwe bladsy.)**

Aanvanklik word 60,8 g suiwer koolstofdiksied,  $\text{CO}_2(\text{g})$ , met koolstof,  $\text{C}(\text{s})$ , in 'n verseelde houer met 'n volume van  $3 \text{ dm}^3$  gereageer. Die reaksie bereik ewewig by temperatuur **T** volgens die volgende gebalanseerde vergelyking:

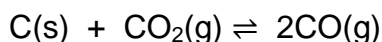

6.1 Definieer die term *chemiese ewewig*. (2)

6.2 By ewewig word daar gevind dat die konsentrasie van die koolstofdiksied  $0,054 \text{ mol}\cdot\text{dm}^{-3}$  is.

Bereken die:

6.2.1 Ewewigskonstante,  $K_c$ , vir hierdie reaksie by temperatuur **T** (7)

6.2.2 Minimum massa  $\text{C}(\text{s})$  wat in die houer teenwoordig moet wees om hierdie ewewig te verkry (3)

6.3 Hoe sal ELK van die volgende veranderinge die HOEVEELHEID  $\text{CO}(\text{g})$  by ewewig beïnvloed?

Kies uit TOENEEM, AFNEEM of BLY DIESELFDE.

6.3.1 Meer koolstof word by die houer gevoeg (1)

6.3.2 Die druk word verhoog deur die volume van die houer by konstante temperatuur te verlaag.  
Gebruik Le Chatelier se beginsel om die antwoord te verduidelik. (3)

6.4 Die tabel hieronder toon die persentasies  $\text{CO}_2(\text{g})$  en  $\text{CO}(\text{g})$  in die houer by verskillende temperature.

TEMPERATUUR ( $^{\circ}\text{C}$ )	% $\text{CO}_2(\text{g})$	% $\text{CO}(\text{g})$
827	6,23	93,77
950	1,32	98,68
1 050	0,37	99,63
1 200	0,06	99,94

6.4.1 Is die reaksie EKSOTERMIES of ENDOTERMIES?  
Verwys na die data in die tabel en verduidelik die antwoord. (3)

6.4.2 Gebruik die inligting in die tabel en bepaal temperatuur **T**.  
Toon duidelik hoe jy die antwoord gekry het. (3)

**[22]**

**VRAAG 7 (Begin op 'n nuwe bladsy.)**

'n Waterstofbromiedoplossing,  $\text{HBr(aq)}$ , reageer met water volgens die volgende gebalanseerde chemiese vergelyking:

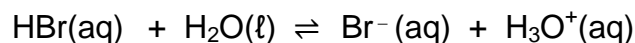

Die  $K_a$ -waarde van  $\text{HBr(aq)}$  by  $25\text{ }^\circ\text{C}$  is  $1 \times 10^9$ .

7.1 Is waterstofbromied 'n STERK SUUR of 'n SWAK SUUR? Gee 'n rede vir die antwoord. (2)

7.2 Skryf die FORMULES van die TWEE basisse in reaksie hierbo neer. (2)

7.3  $\text{HBr(aq)}$  reageer met  $\text{Zn(OH)}_2(\text{s})$  volgens die volgende gebalanseerde vergelyking:

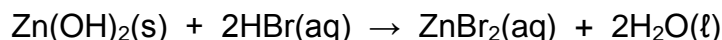

'n Onbekende hoeveelheid  $\text{Zn(OH)}_2(\text{s})$  word met  $90\text{ cm}^3$   $\text{HBr(aq)}$  in 'n fles gereageer. (Aanvaar dat die volume van die oplossing nie tydens die reaksie verander nie.)

Die OORMAAT  $\text{HBr(aq)}$  word dan deur  $16,5\text{ cm}^3$   $\text{NaOH(aq)}$  met 'n konsentrasie van  $0,5\text{ mol}\cdot\text{dm}^{-3}$  geneutraliseer. Die gebalanseerde vergelyking vir die reaksie is:

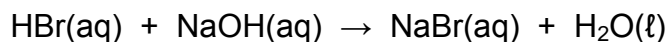

7.3.1 Bereken die pH van die  $\text{HBr}$ -oplossing wat in die fles oorbly NA die reaksie met  $\text{Zn(OH)}_2(\text{s})$ . (7)

7.3.2 Bereken die massa  $\text{Zn(OH)}_2(\text{s})$  wat AANVANKLIK in die fles verteenwoordig is indien die aanvanklike konsentrasie  $\text{HBr(aq)}$ ,  $0,45\text{ mol}\cdot\text{dm}^{-3}$  was. (6)  
**[17]**

**VRAAG 8 (Begin op 'n nuwe bladsy.)**

'n Standaard elektrochemiese sel word opgestel deur twee standaardhalfselle te gebruik, soos in die diagram hieronder getoon.

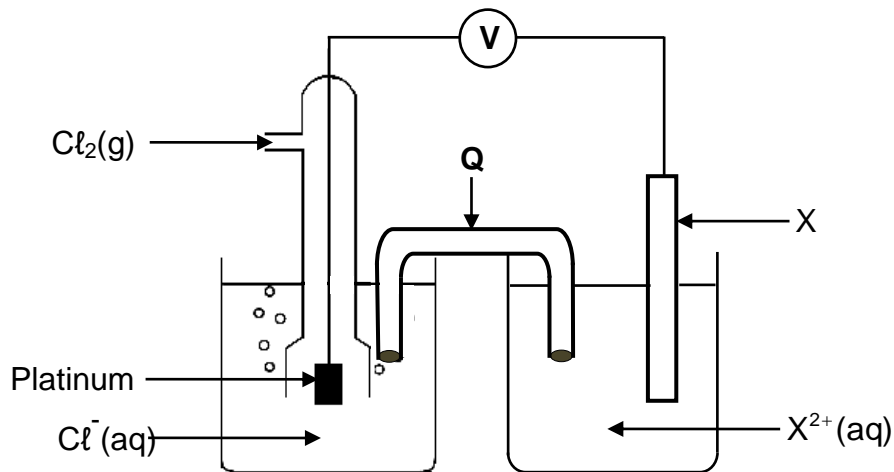

- 8.1 Noem die energie-omsetting wat in hierdie sel plaasvind. (1)
- 8.2 Wat is die funksie van komponent **Q**? (1)
- X** is 'n metaal. 'n Voltmeter wat oor die sel verbind is, registreer aanvanklik 1,49 V.
- 8.3 Gebruik 'n berekening om metaal **X** te identifiseer. (5)
- 8.4 Skryf die NAAM of FORMULE van die reduseermiddel neer. (1)
- 8.5 Nadat die sel vir verskeie ure gebruik is, verander die lesing op die voltmeter na NUL.
- 8.5.1 Gee 'n rede vir hierdie lesing deur te verwys na die tempo's van oksidasie- en reduksiehalfreaksies wat in die sel plaasvind. (1)
- 'n Silwernitratoplossing,  $\text{AgNO}_3(\text{aq})$ , word NOU by die chloorhalfsel gevoeg en 'n neerslag vorm.
- 8.5.2 Hoe sal die lesing op die voltmeter beïnvloed word? (Kies uit TOENEEM, AFNEEM of BLY DIESELFDE) (1)
- 8.5.3 Gebruik Le Chatelier se beginsel om die antwoord op VRAAG 8.5.2 te verduidelik. (2)

**[12]**

**VRAAG 9 (Begin op 'n nuwe bladsy.)**

Chloor word in die nywerheid berei deur die elektrolise van 'n gekonsentreerde natriumchloriedoplossing, NaCl(aq).

Die gebalanseerde vergelyking vir die netto (algehele) selreaksie is soos volg:

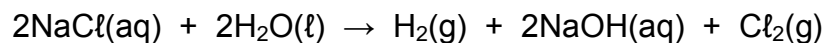

- 9.1 Definieer die term *elektrolise*. (2)
- 9.2 Vir die reaksie hierbo, skryf neer die:
- 9.2.1 Halfreaksie wat by die katode plaasvind (2)
- 9.2.2 NAAM of FORMULE van die oksideermiddel (1)
- 9.3 Verwys na die Tabel van Standaardreduksie-potensiale om te verduidelik waarom natriumione nie tydens hierdie proses gereduseer word nie. (3)

**[8]**

**VRAAG 10 (Begin op 'n nuwe bladsy.)**

Die vloeddiagram hieronder toon die prosesse wat betrokke is by die nywerheidsbereiding van 'n ammoniumkunsmiss.

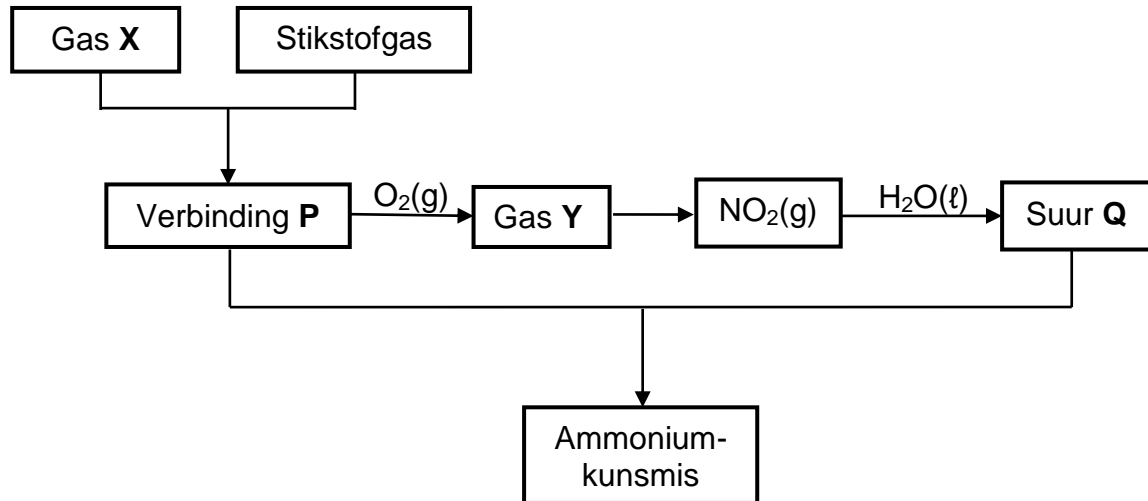

10.1 Skryf die NAAM of FORMULE neer van:

10.1.1 Gas **X** (1)

10.1.2 Gas **Y** (1)

10.1.3 Suur **Q** (1)

10.2 Skryf neer die:

10.2.1 TIPE chemiese reaksie wat verbinding **P** na gas **Y** omskakel (1)

10.2.2 Gebalanseerde vergelyking vir die reaksie tussen verbinding **P** en suur **Q** (3)

10.3 Twee aparte sakke met kunsmiss is soos volg gemerk:



10.3.1 Wat stel die getalle (21) en (27) op die sakke voor? (1)

10.3.2 Gebruik 'n berekening om te bepaal watter sak (**A** of **B**) die grootste massa fosfor bevat. (4)  
[12]

**TOTAAL: 150**

**DATA FOR PHYSICAL SCIENCES GRADE 12  
PAPER 2 (CHEMISTRY)**

**GEGEWENS VIR FISIESTE WETENSKAPPE GRAAD 12  
VRAESTEL 2 (CHEMIE)**

**TABLE 1: PHYSICAL CONSTANTS/TABEL 1: FISIESTE KONSTANTES**

NAME/NAAM	SYMBOL/SIMBOOL	VALUE/WAARDE
Standard pressure <i>Standaarddruk</i>	$p^\theta$	$1,013 \times 10^5 \text{ Pa}$
Molar gas volume at STP <i>Molêre gasvolume by STD</i>	$V_m$	$22,4 \text{ dm}^3 \cdot \text{mol}^{-1}$
Standard temperature <i>Standaardtemperatuur</i>	$T^\theta$	273 K
Charge on electron <i>Lading op elektron</i>	$e$	$-1,6 \times 10^{-19} \text{ C}$
Avogadro's constant <i>Avogadro-konstante</i>	$N_A$	$6,02 \times 10^{23} \text{ mol}^{-1}$

**TABLE 2: FORMULAE/TABEL 2: FORMULES**

$n = \frac{m}{M}$	$n = \frac{N}{N_A}$
$c = \frac{n}{V}$ or/of $c = \frac{m}{MV}$	$n = \frac{V}{V_m}$
$\frac{c_a v_a}{c_b v_b} = \frac{n_a}{n_b}$	$\text{pH} = -\log[\text{H}_3\text{O}^+]$
$K_w = [\text{H}_3\text{O}^+][\text{OH}^-] = 1 \times 10^{-14}$ at/by 298 K	
$E_{\text{cell}}^\theta = E_{\text{cathode}}^\theta - E_{\text{anode}}^\theta$ / $E_{\text{sel}}^\theta = E_{\text{katode}}^\theta - E_{\text{anode}}^\theta$	
or/of	
$E_{\text{cell}}^\theta = E_{\text{reduction}}^\theta - E_{\text{oxidation}}^\theta$ / $E_{\text{sel}}^\theta = E_{\text{reduksie}}^\theta - E_{\text{oksidasie}}^\theta$	
or/of	
$E_{\text{cell}}^\theta = E_{\text{oxidisingagent}}^\theta - E_{\text{reducingagent}}^\theta$ / $E_{\text{sel}}^\theta = E_{\text{oksideermiddel}}^\theta - E_{\text{reduseermiddel}}^\theta$	

**TABLE 3: THE PERIODIC TABLE OF ELEMENTS**  
**TABEL 3: DIE PERIODIEKE TABEL VAN ELEMENTE**

1 (I)	2 (II)	3	4	5	6	7	8	9	10	11	12	13 (III)	14 (IV)	15 (V)	16 (VI)	17 (VII)	18 (VIII)
1 2,1 <b>H</b>																	2 4 <b>He</b>
3 1,0 <b>Li</b>	4 1,5 <b>Be</b>											5 2,0 <b>B</b>	6 2,5 <b>C</b>	7 3,0 <b>N</b>	8 3,5 <b>O</b>	9 4,0 <b>F</b>	10 20 <b>Ne</b>
11 0,9 <b>Na</b>	12 1,2 <b>Mg</b>											13 1,5 <b>Al</b>	14 1,8 <b>Si</b>	15 2,1 <b>P</b>	16 2,5 <b>S</b>	17 3,0 <b>Cl</b>	18 40 <b>Ar</b>
19 0,8 <b>K</b>	20 1,0 <b>Ca</b>	21 1,3 <b>Sc</b>	22 1,5 <b>Ti</b>	23 1,6 <b>V</b>	24 1,6 <b>Cr</b>	25 1,5 <b>Mn</b>	26 1,8 <b>Fe</b>	27 1,8 <b>Co</b>	28 1,8 <b>Ni</b>	29 1,9 <b>Cu</b>	30 1,6 <b>Zn</b>	31 1,6 <b>Ga</b>	32 1,8 <b>Ge</b>	33 2,0 <b>As</b>	34 2,4 <b>Se</b>	35 2,8 <b>Br</b>	36 84 <b>Kr</b>
37 0,8 <b>Rb</b>	38 1,0 <b>Sr</b>	39 1,2 <b>Y</b>	40 1,4 <b>Zr</b>	41 1,6 <b>Nb</b>	42 1,8 <b>Mo</b>	43 1,9 <b>Tc</b>	44 2,2 <b>Ru</b>	45 2,2 <b>Rh</b>	46 2,2 <b>Pd</b>	47 1,9 <b>Ag</b>	48 1,7 <b>Cd</b>	49 1,7 <b>In</b>	50 1,8 <b>Sn</b>	51 1,9 <b>Sb</b>	52 2,1 <b>Te</b>	53 2,5 <b>I</b>	54 131 <b>Xe</b>
55 0,7 <b>Cs</b>	56 0,9 <b>Ba</b>	57 1,39 <b>La</b>	72 1,6 <b>Hf</b>	73 1,81 <b>Ta</b>	74 1,84 <b>W</b>	75 1,86 <b>Re</b>	76 1,90 <b>Os</b>	77 1,92 <b>Ir</b>	78 1,95 <b>Pt</b>	79 1,97 <b>Au</b>	80 2,01 <b>Hg</b>	81 1,8 <b>Tl</b>	82 1,8 <b>Pb</b>	83 1,9 <b>Bi</b>	84 2,0 <b>Po</b>	85 2,5 <b>At</b>	86 209 <b>Rn</b>
87 0,7 <b>Fr</b>	88 0,9 <b>Ra</b>	89 226 <b>Ac</b>															
			58 <b>Ce</b>	59 <b>Pr</b>	60 <b>Nd</b>	61 <b>Pm</b>	62 <b>Sm</b>	63 <b>Eu</b>	64 <b>Gd</b>	65 <b>Tb</b>	66 <b>Dy</b>	67 <b>Ho</b>	68 <b>Er</b>	69 <b>Tm</b>	70 <b>Yb</b>	71 <b>Lu</b>	
			90 <b>Th</b>	91 <b>Pa</b>	92 <b>U</b>	93 <b>Np</b>	94 <b>Pu</b>	95 <b>Am</b>	96 <b>Cm</b>	97 <b>Bk</b>	98 <b>Cf</b>	99 <b>Es</b>	100 <b>Fm</b>	101 <b>Md</b>	102 <b>No</b>	103 <b>Lr</b>	

KEY/SLEUTEL

Atomic number  
*Atoomgetal*

Electronegativity  
*Elektronegatiwiteit*

Symbol  
*Simbool*

29 <b>Cu</b> 63,5
-------------------------

Approximate relative atomic mass  
*Benaderde relatiewe atoommassa*

**TABLE 4A: STANDARD REDUCTION POTENTIALS**  
**TABEL 4A: STANDAARD-REDUKSIEPOTENSIALE**

Increasing oxidising ability/Toenemende oksiderende vermoë

Increasing reducing ability/Toenemende reduserende vermoë

Half-reactions/Halfreaksies	E <sup>θ</sup> (V)
F <sub>2</sub> (g) + 2e <sup>-</sup> ⇌ 2F <sup>-</sup>	+ 2,87
Co <sup>3+</sup> + e <sup>-</sup> ⇌ Co <sup>2+</sup>	+ 1,81
H <sub>2</sub> O <sub>2</sub> + 2H <sup>+</sup> + 2e <sup>-</sup> ⇌ 2H <sub>2</sub> O	+1,77
MnO <sub>4</sub> <sup>-</sup> + 8H <sup>+</sup> + 5e <sup>-</sup> ⇌ Mn <sup>2+</sup> + 4H <sub>2</sub> O	+ 1,51
Cl <sub>2</sub> (g) + 2e <sup>-</sup> ⇌ 2Cl <sup>-</sup>	+ 1,36
Cr <sub>2</sub> O <sub>7</sub> <sup>2-</sup> + 14H <sup>+</sup> + 6e <sup>-</sup> ⇌ 2Cr <sup>3+</sup> + 7H <sub>2</sub> O	+ 1,33
O <sub>2</sub> (g) + 4H <sup>+</sup> + 4e <sup>-</sup> ⇌ 2H <sub>2</sub> O	+ 1,23
MnO <sub>2</sub> + 4H <sup>+</sup> + 2e <sup>-</sup> ⇌ Mn <sup>2+</sup> + 2H <sub>2</sub> O	+ 1,23
Pt <sup>2+</sup> + 2e <sup>-</sup> ⇌ Pt	+ 1,20
Br <sub>2</sub> (l) + 2e <sup>-</sup> ⇌ 2Br <sup>-</sup>	+ 1,07
NO <sub>3</sub> <sup>-</sup> + 4H <sup>+</sup> + 3e <sup>-</sup> ⇌ NO(g) + 2H <sub>2</sub> O	+ 0,96
Hg <sup>2+</sup> + 2e <sup>-</sup> ⇌ Hg(l)	+ 0,85
Ag <sup>+</sup> + e <sup>-</sup> ⇌ Ag	+ 0,80
NO <sub>3</sub> <sup>-</sup> + 2H <sup>+</sup> + e <sup>-</sup> ⇌ NO <sub>2</sub> (g) + H <sub>2</sub> O	+ 0,80
Fe <sup>3+</sup> + e <sup>-</sup> ⇌ Fe <sup>2+</sup>	+ 0,77
O <sub>2</sub> (g) + 2H <sup>+</sup> + 2e <sup>-</sup> ⇌ H <sub>2</sub> O <sub>2</sub>	+ 0,68
I <sub>2</sub> + 2e <sup>-</sup> ⇌ 2I <sup>-</sup>	+ 0,54
Cu <sup>+</sup> + e <sup>-</sup> ⇌ Cu	+ 0,52
SO <sub>2</sub> + 4H <sup>+</sup> + 4e <sup>-</sup> ⇌ S + 2H <sub>2</sub> O	+ 0,45
2H <sub>2</sub> O + O <sub>2</sub> + 4e <sup>-</sup> ⇌ 4OH <sup>-</sup>	+ 0,40
Cu <sup>2+</sup> + 2e <sup>-</sup> ⇌ Cu	+ 0,34
SO <sub>4</sub> <sup>2-</sup> + 4H <sup>+</sup> + 2e <sup>-</sup> ⇌ SO <sub>2</sub> (g) + 2H <sub>2</sub> O	+ 0,17
Cu <sup>2+</sup> + e <sup>-</sup> ⇌ Cu <sup>+</sup>	+ 0,16
Sn <sup>4+</sup> + 2e <sup>-</sup> ⇌ Sn <sup>2+</sup>	+ 0,15
S + 2H <sup>+</sup> + 2e <sup>-</sup> ⇌ H <sub>2</sub> S(g)	+ 0,14
<b>2H<sup>+</sup> + 2e<sup>-</sup> ⇌ H<sub>2</sub>(g)</b>	<b>0,00</b>
Fe <sup>3+</sup> + 3e <sup>-</sup> ⇌ Fe	- 0,06
Pb <sup>2+</sup> + 2e <sup>-</sup> ⇌ Pb	- 0,13
Sn <sup>2+</sup> + 2e <sup>-</sup> ⇌ Sn	- 0,14
Ni <sup>2+</sup> + 2e <sup>-</sup> ⇌ Ni	- 0,27
Co <sup>2+</sup> + 2e <sup>-</sup> ⇌ Co	- 0,28
Cd <sup>2+</sup> + 2e <sup>-</sup> ⇌ Cd	- 0,40
Cr <sup>3+</sup> + e <sup>-</sup> ⇌ Cr <sup>2+</sup>	- 0,41
Fe <sup>2+</sup> + 2e <sup>-</sup> ⇌ Fe	- 0,44
Cr <sup>3+</sup> + 3e <sup>-</sup> ⇌ Cr	- 0,74
Zn <sup>2+</sup> + 2e <sup>-</sup> ⇌ Zn	- 0,76
2H <sub>2</sub> O + 2e <sup>-</sup> ⇌ H <sub>2</sub> (g) + 2OH <sup>-</sup>	- 0,83
Cr <sup>2+</sup> + 2e <sup>-</sup> ⇌ Cr	- 0,91
Mn <sup>2+</sup> + 2e <sup>-</sup> ⇌ Mn	- 1,18
Al <sup>3+</sup> + 3e <sup>-</sup> ⇌ Al	- 1,66
Mg <sup>2+</sup> + 2e <sup>-</sup> ⇌ Mg	- 2,36
Na <sup>+</sup> + e <sup>-</sup> ⇌ Na	- 2,71
Ca <sup>2+</sup> + 2e <sup>-</sup> ⇌ Ca	- 2,87
Sr <sup>2+</sup> + 2e <sup>-</sup> ⇌ Sr	- 2,89
Ba <sup>2+</sup> + 2e <sup>-</sup> ⇌ Ba	- 2,90
Cs <sup>+</sup> + e <sup>-</sup> ⇌ Cs	- 2,92
K <sup>+</sup> + e <sup>-</sup> ⇌ K	- 2,93
Li <sup>+</sup> + e <sup>-</sup> ⇌ Li	- 3,05

**TABLE 4B: STANDARD REDUCTION POTENTIALS**  
**TABEL 4B: STANDAARD-REDUKSIEPOTENSIALE**

Half-reactions/ <i>Halfreaksies</i>	$E^\theta$ (V)
$\text{Li}^+ + e^- \rightleftharpoons \text{Li}$	-3,05
$\text{K}^+ + e^- \rightleftharpoons \text{K}$	-2,93
$\text{Cs}^+ + e^- \rightleftharpoons \text{Cs}$	-2,92
$\text{Ba}^{2+} + 2e^- \rightleftharpoons \text{Ba}$	-2,90
$\text{Sr}^{2+} + 2e^- \rightleftharpoons \text{Sr}$	-2,89
$\text{Ca}^{2+} + 2e^- \rightleftharpoons \text{Ca}$	-2,87
$\text{Na}^+ + e^- \rightleftharpoons \text{Na}$	-2,71
$\text{Mg}^{2+} + 2e^- \rightleftharpoons \text{Mg}$	-2,36
$\text{Al}^{3+} + 3e^- \rightleftharpoons \text{Al}$	-1,66
$\text{Mn}^{2+} + 2e^- \rightleftharpoons \text{Mn}$	-1,18
$\text{Cr}^{2+} + 2e^- \rightleftharpoons \text{Cr}$	-0,91
$2\text{H}_2\text{O} + 2e^- \rightleftharpoons \text{H}_2(\text{g}) + 2\text{OH}^-$	-0,83
$\text{Zn}^{2+} + 2e^- \rightleftharpoons \text{Zn}$	-0,76
$\text{Cr}^{3+} + 3e^- \rightleftharpoons \text{Cr}$	-0,74
$\text{Fe}^{2+} + 2e^- \rightleftharpoons \text{Fe}$	-0,44
$\text{Cr}^{3+} + e^- \rightleftharpoons \text{Cr}^{2+}$	-0,41
$\text{Cd}^{2+} + 2e^- \rightleftharpoons \text{Cd}$	-0,40
$\text{Co}^{2+} + 2e^- \rightleftharpoons \text{Co}$	-0,28
$\text{Ni}^{2+} + 2e^- \rightleftharpoons \text{Ni}$	-0,27
$\text{Sn}^{2+} + 2e^- \rightleftharpoons \text{Sn}$	-0,14
$\text{Pb}^{2+} + 2e^- \rightleftharpoons \text{Pb}$	-0,13
$\text{Fe}^{3+} + 3e^- \rightleftharpoons \text{Fe}$	-0,06
<b><math>2\text{H}^+ + 2e^- \rightleftharpoons \text{H}_2(\text{g})</math></b>	<b>0,00</b>
$\text{S} + 2\text{H}^+ + 2e^- \rightleftharpoons \text{H}_2\text{S}(\text{g})$	+0,14
$\text{Sn}^{4+} + 2e^- \rightleftharpoons \text{Sn}^{2+}$	+0,15
$\text{Cu}^{2+} + e^- \rightleftharpoons \text{Cu}^+$	+0,16
$\text{SO}_4^{2-} + 4\text{H}^+ + 2e^- \rightleftharpoons \text{SO}_2(\text{g}) + 2\text{H}_2\text{O}$	+0,17
$\text{Cu}^{2+} + 2e^- \rightleftharpoons \text{Cu}$	+0,34
$2\text{H}_2\text{O} + \text{O}_2 + 4e^- \rightleftharpoons 4\text{OH}^-$	+0,40
$\text{SO}_2 + 4\text{H}^+ + 4e^- \rightleftharpoons \text{S} + 2\text{H}_2\text{O}$	+0,45
$\text{Cu}^+ + e^- \rightleftharpoons \text{Cu}$	+0,52
$\text{I}_2 + 2e^- \rightleftharpoons 2\text{I}^-$	+0,54
$\text{O}_2(\text{g}) + 2\text{H}^+ + 2e^- \rightleftharpoons \text{H}_2\text{O}_2$	+0,68
$\text{Fe}^{3+} + e^- \rightleftharpoons \text{Fe}^{2+}$	+0,77
$\text{NO}_3^- + 2\text{H}^+ + e^- \rightleftharpoons \text{NO}_2(\text{g}) + \text{H}_2\text{O}$	+0,80
$\text{Ag}^+ + e^- \rightleftharpoons \text{Ag}$	+0,80
$\text{Hg}^{2+} + 2e^- \rightleftharpoons \text{Hg}(\ell)$	+0,85
$\text{NO}_3^- + 4\text{H}^+ + 3e^- \rightleftharpoons \text{NO}(\text{g}) + 2\text{H}_2\text{O}$	+0,96
$\text{Br}_2(\ell) + 2e^- \rightleftharpoons 2\text{Br}^-$	+1,07
$\text{Pt}^{2+} + 2e^- \rightleftharpoons \text{Pt}$	+1,20
$\text{MnO}_2 + 4\text{H}^+ + 2e^- \rightleftharpoons \text{Mn}^{2+} + 2\text{H}_2\text{O}$	+1,23
$\text{O}_2(\text{g}) + 4\text{H}^+ + 4e^- \rightleftharpoons 2\text{H}_2\text{O}$	+1,23
$\text{Cr}_2\text{O}_7^{2-} + 14\text{H}^+ + 6e^- \rightleftharpoons 2\text{Cr}^{3+} + 7\text{H}_2\text{O}$	+1,33
$\text{Cl}_2(\text{g}) + 2e^- \rightleftharpoons 2\text{Cl}^-$	+1,36
$\text{MnO}_4^- + 8\text{H}^+ + 5e^- \rightleftharpoons \text{Mn}^{2+} + 4\text{H}_2\text{O}$	+1,51
$\text{H}_2\text{O}_2 + 2\text{H}^+ + 2e^- \rightleftharpoons 2\text{H}_2\text{O}$	+1,77
$\text{Co}^{3+} + e^- \rightleftharpoons \text{Co}^{2+}$	+1,81
$\text{F}_2(\text{g}) + 2e^- \rightleftharpoons 2\text{F}^-$	+2,87

Increasing oxidising ability/*Toenemende oksiderende vermoë*

Increasing reducing ability/*Toenemende reduserende vermoë*



# basic education

Department:  
Basic Education  
**REPUBLIC OF SOUTH AFRICA**

**NATIONAL  
SENIOR CERTIFICATE  
NASIONALE  
SENIOR SERTIFIKAAT**

**GRADE/GRAAD 12**

**PHYSICAL SCIENCES: CHEMISTRY (P2)  
FISIESE WETENSKAPPE: CHEMIE (V2)**

**NOVEMBER 2019**

**MARKING GUIDELINES/NASIENRIGLYNE**

**MARKS/PUNTE: 150**

**These marking guidelines consist of 20 pages.  
*Hierdie nasienriglyne bestaan uit 20 bladsye.***

### QUESTION 1/VRAAG 1

- 1.1 D ✓✓ (2)
- 1.2 C ✓✓ (2)
- 1.3 B ✓✓ (2)
- 1.4 D ✓✓ (2)
- 1.5 C ✓✓ (2)
- 1.6 B ✓✓ (2)
- 1.7 B ✓✓ (2)
- 1.8 A ✓✓ (2)
- 1.9 A ✓✓ (2)
- 1.10 C ✓✓ (2)
- [20]**

### QUESTION 2/VRAAG 2

2.1

- 2.1.1  $C_nH_{2n-2}$  ✓ (1)

2.1.2

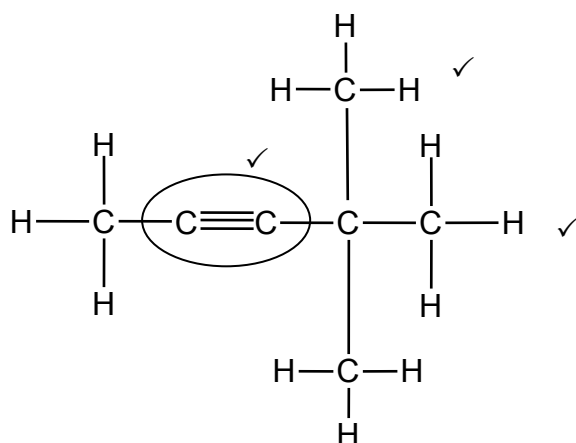

#### **Marking criteria/Nasiemriglyne**

- Functional group correct. ✓  
*Funksionele groep korrek.*
- 2 methyl substituents. ✓  
*2 metielsubstituente.*
- Whole structure correct: /Hele  
*struktuur korrek:*  $\frac{3}{3}$

(3)

2.2

2.2.1 Compounds with the same molecular formula, ✓ but different positions of the side chain/substituents/functional groups ✓ on the parent chain.  
*Verbindings met dieselfde molekulêre formule, maar verskillende posisies van die syketting/substituente/funksionele groepe op die stamketting.* (2)

2.2.2 Pentan-3-one/3-pentanone ✓✓  
 Pentan-3-oon/3-pentanoon

**Marking criteria/Nasienriglyne**

- Functional group and correct position i.e. 3 /Funksionele groep en korrekte posisie nl. 3. ✓
- Whole name correct/Hele naam korrek. ✓

**Accept for ONE mark/Aanvaar vir EEN punt**

Pentanone with the 3 in incorrect place, e.g. penta-3-none.  
 Pentanoon met die 3 in foutiewe plek, bv. penta-3-noon.

(2)

2.2.3

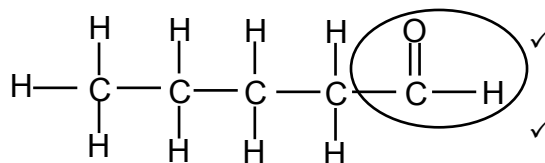

**Marking criteria/Nasienriglyne**

- Whole structure correct:/Hele struktuur korrek:  $\frac{2}{2}$
- Only functional group correct/Slegs funksionele groep korrek Max:  $\frac{1}{2}$

**OR: Any correct structure of an aldehyde with five carbon atoms.**

**OF: Enige korrekte struktuur van 'n aldehied met vyf koolstofatome.**

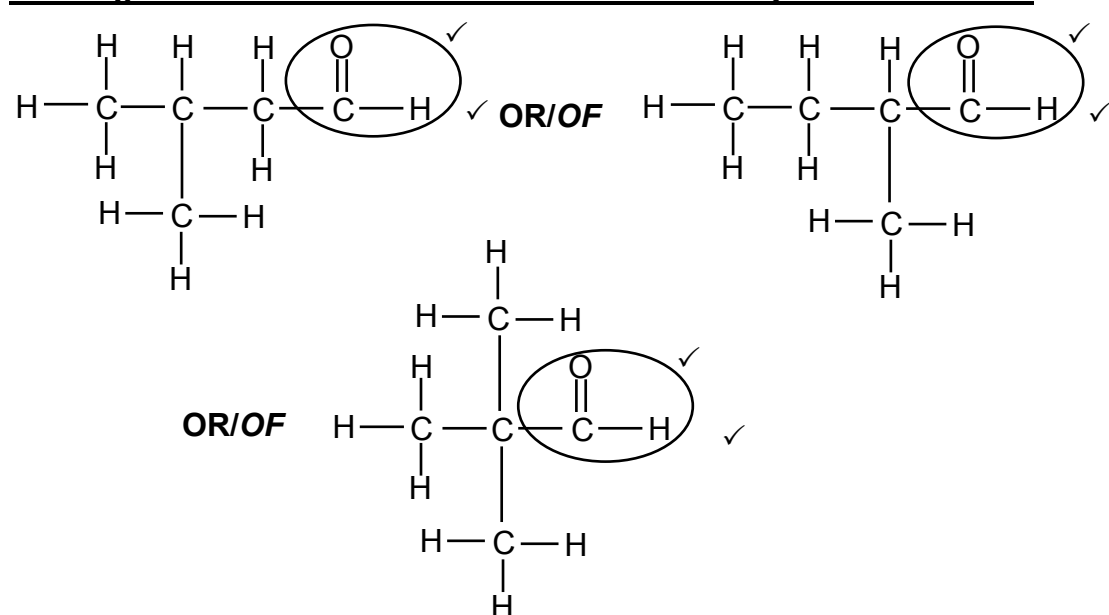

(2)

2.3

2.3.1 Tertiary (alcohol)/Tersiêre (alkohol) ✓

The C atom bonded to the functional group/hydroxyl (group)/-OH is bonded to three other C atoms. /The C-atom bonded to the hydroxyl (group) has no hydrogen atoms. ✓

*Die C-atoom gebind aan die funksionele groep/hidroksiel(groep)/-OH is gebind aan drie ander C-atome./ Die C-atoom gebind aan die hidroksiel (groep) het geen waterstofatome nie.*

(2)

2.3.2 2-methylbutan-2-ol/2-methyl-2-butanol/2-metielbutan-2-ol/2-metiel-2-butanol

**Marking criteria/Nasienriglyne**

- 2-methyl/2-metiel ✓
- Butan-2-ol/2-butanol ✓
- Any error e.g. hyphens omitted and/or incorrect sequence:

*Enige fout, bv. koppeltekens weggelaat en/of verkeerde volgorde: Max./Maks: 1/2*

(2)

2.3.3 2-methylbut-2-ene/2-methyl-2-butene/2-metielbut-2-ene/2-metiel-2-buteen

**Marking criteria/Nasienriglyne**

- 2-methyl/2-metiel ✓
- But-2-ene/2-butene/But-2-ene/2-buteen ✓
- Any error e.g. hyphens omitted and/or incorrect sequence:

*Enige fout, bv. koppeltekens weggelaat en/of verkeerde volgorde: Max./Maks: 1/2*

(2)

[16]

### QUESTION 3/VRAAG 3

3.1

**Marking guidelines/Nasienriglyne**

The underlined key phrases must be used in the **CORRECT CONTEXT (pressure/boiling)**. /Die onderstreepte frases moet gebruik word in die **KORREKTE KONTEKS (druk/kook)**.

The temperature ✓ at which the vapour pressure of a substance equals atmospheric/external pressure. ✓

*Die temperatuur waar die dampdruk van 'n stof gelyk is aan atmosferiese/eksterne druk.*

(2)

3.2 (Q, R and S) have same molecular mass/formulae/number of carbon and hydrogen atoms/are (chain) isomers. ✓  
*(Q, R en S) het dieselfde molekulêre massa/formule/aantal koolstof en waterstofatome/ is (ketting)isomere.*

**OR/OF**

The compounds are all alkanes /same homologous series and have the same number of carbon atoms.

*Die verbindings is almal alkane /dieselfde homoloë reeks en het die dieselfde aantal koolstofatome.*

(1)

**Marking guidelines/Nasienriglyne**

- 55 (°C) ✓
- Compare all three compounds or Q and S in terms of branches/chain lengths / surface area. ✓  
*Vergelyk al drie verbindings of Q en S in terme van vertakkings/kettinglengte/ oppervlakarea.*
- Compare strengths of all three or Q and S's IMF's / *Vergelyk sterkte van al drie of Q en S se IMK'e.* ✓
- Compare energy of all three / *Vergelyk energie van al drie.* ✓

3.3

55 (°C) ✓

**Compare compound R with compounds Q and S:**

- Compound **R** is less branched/compact/spherical/surface area than compound **Q** and more branched/compact/spherical/surface area than compound **S**. ✓  
**OR**  
**Q** is the most branched/compact /spherical/surface area and **S** is least branched/compact/spherical/surface area.
- Intermolecular forces in compound R are stronger than in compound Q and weaker than in compound S. ✓
- More energy needed to overcome intermolecular forces in compound R than in compound Q and less energy needed to overcome (break) intermolecular forces in compound R than in compound S. ✓

**OR**

- Compound **R** has a longer chain length than compound **Q** and a shorter chain length than compound **S**. ✓  
**OR**  
**S** has the longest chain length and **Q** the shortest.
- Intermolecular forces increase with increase in chain length. ✓
- More energy needed to overcome intermolecular forces as chain length increases. ✓

**Vergelyk verbinding R met verbindings Q en S:**

- Verbinding R is minder vertak/kompak/sferieseoppervlak as verbinding Q en meer vertak as verbinding S.

**OF**

Q is die meeste vertak/kompak en S is die minste vertak/kompak/series/oppervlak.

- Intermolekulêre kragte in verbinding R is sterker as in verbinding Q en swakker as in verbinding S.
- Meer energie word benodig om intermolekulêre kragte in verbinding R te oorkom as in verbinding Q, en minder energie word benodig om intermolekulêre kragte in verbinding R te oorkom / breek as in verbinding S.

**OF**

- Verbinding R het 'n langer kettinglengte as verbinding Q en 'n korter kettinglengte as S.

**OF**

**S** het die langste ketting en **Q** die kortste.

- Intermolekulêre kragte neem toe met toename in kettinglengte.
- Meer energie word benodig om intermolekulêre kragte te oorkom wanneer kettinglengte toeneem.

(4)

3.4

3.4.1 P ✓✓

(2)

3.4.2

**Marking guidelines/Nasienriglyne**

- Name type of IMFs in **P/pentanal**. ✓  
*Noem tipe IMK'e in P/pentanaal.*
  - Name type of IMFs in/*Noem tipe IMK'e in T/pentan-1-ol.* ✓
  - Compare strength of IMFs. /*Vergelyk sterkte van IMK'e.* ✓
- OR/OF**  
Compare energy needed to overcome IMFs. /*Vergelyk energie benodig om IMK'e te oorkom.*

- In **P/ pentanal**/aldehydes: dipole-dipole forces ✓ (in addition to London forces/dispersion forces/induced dipole forces).
- In **T/pentan-1-ol**: Hydrogen bonding. ✓ (in addition to London forces/dispersion forces/induced dipole forces).
- Intermolecular forces in P/pentanal are weaker ✓ than in **T/pentan-1-ol**  
**OR** dipole-dipole forces are weaker than hydrogen bonds **OR**  
intermolecular forces in **T/pentan-1-ol** are stronger than in **P/pentanal**.  
**OR**  
More energy needed to overcome/break intermolecular forces in T.
- *In P/pentanaal/aldehyede: dipool-dipoolkragte (tesame met Londonkragte/dispersiekragte/geïnduseerde dipoolkragte).*
- *In T/pentan-1-ol: Waterstofbinding. (tesame met Londonkragte/dispersiekragte/geïnduseerde dipoolkragte).*
- Intermolekulêre kragte in P swakker as in T/pentan-1-ol **OF**  
*intermolekulêre kragte in T/pentan-1-ol sterker as in P/pentanaal* **OF**  
*dipool-dipoolkragte is swakker as waterstofbindings.*  
**OF**  
Meer energie benodig om intermolekulêre kragte te oorkom/breek in T.

(3)

[12]

#### QUESTION 4/VRAAG 4

4.1 Haloalkane/alkyl halide ✓  
*Haloalkaan/alkielhalied* (1)

4.2  
4.2.1 Elimination/dehydrohalogenation ✓  
*Eliminasie/dehidrohalogenering* (1)

4.2.2 Substitution/hydrolysis ✓  
*Substitusie/hidrolise* (1)

4.2.3 Esterification/condensation ✓  
*Esterifikasie/kondensasie/verestering* (1)

4.3  
4.3.1 • (Mild) heat/Heating/(*matige*) *hitte*/ *verhitting* ✓  
• Dilute (strong base)/*Verdunde (sterk basis)*/(NaOH/KOH/LiOH) ✓  
**OR/OR**  
Add water/H<sub>2</sub>O/*Voeg water/H<sub>2</sub>O by* (2)

4.3.2 Propan-1-ol/1-propanol ✓✓  
**Marking criteria/Nasierriglyne:**  
• Correct stem and functional group i.e. propanol/*Korrekte stam en funksionele groep, d.i. propanol.* ✓  
• Whole name correct:/*Hele naam korrek:* propan-1-ol ✓ (2)

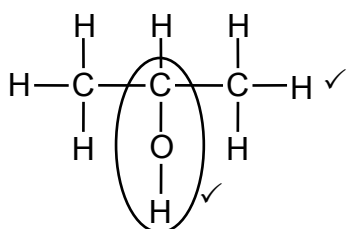
4.4  **Marking criteria/Nasierriglyne**  
• Whole structure correct:/*Hele struktuur korrek:* 2/2  
• Only functional group correct/*Slegs funksionele groep korrek:* 1/2

**Notes/Aantekeninge**  
• Accept –OH as condensed. /*Aanvaar –OH as gekondenseerd.*  
• Condensed or semi-structural formula:  
*Gekondenseerde of semi-struktuurformule:* Max./*Maks.* 1/2  
• Molecular formula/*Molekulêre formule:* 0/2  
• If functional group is incorrect/*Indien funksionele groep verkeerd is:* 0/2  
• If more than one functional group:  
*Indien meer as een funksionele groep:* 0/2 (2)

4.5

**POSITIVE MARKING FROM Q4.3.2 ONLY IF THE COMPOUND IN Q4.3.2 IS AN ALCOHOL. /POSITIEWE NASIEN VANAF V4.3.2 SLEGS INDIEN DIE VERBINDING IN Q4.3.2 'N ALKOHOL IS.**

4.5.1

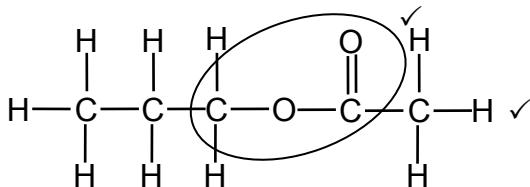

**Marking criteria/Nasienriglyne**

- Whole structure correct:/Hele struktuur korrek:  $\frac{2}{2}$
- Only functional group correct/Slegs funksionele groep korrek:  $\frac{1}{2}$

**Notes/Aantekeninge**

- Condensed or semi-structural formula:  
 Gekondenseerde of semistruktuurformule: Max./Maks.  $\frac{1}{2}$
- Molecular formula/Molekulêre formule:  $\frac{0}{2}$
- If functional group is incorrect/Indien funksionele groep verkeerd is:  $\frac{0}{2}$

(2)

4.5.2 (Concentrated) sulphuric acid/(Gekonsentreerde) swawelsuur/H<sub>2</sub>SO<sub>4</sub> ✓

(1)

**[13]**

**QUESTION 5/VRAAG 5**

5.1 Exothermic/Eksotermies ✓



ΔH < 0/Energy is released/Energie word vrygestel ✓

(2)

5.2

$$\begin{aligned} \text{rate/tempo} &= -\frac{\Delta m}{\Delta t} \\ &= -\frac{0,25 - 2}{30} \checkmark \\ &= 0,06 \text{ (g} \cdot \text{s}^{-1}) \checkmark \\ &\quad (0,0583 \text{ g} \cdot \text{s}^{-1}) \end{aligned}$$

**OR/OF**

$$\begin{aligned} \text{rate/tempo} &= -\frac{\Delta m}{\Delta t} \\ &= -\frac{-1,75}{30} \checkmark \\ &= 0,06 \text{ (g} \cdot \text{s}^{-1}) \checkmark \\ &\quad (0,0583 \text{ g} \cdot \text{s}^{-1}) \end{aligned}$$

(3)

**Notes/Aantekeninge**

**Accept** negative answer i.e./Aanvaar negatiewe antwoord d.i. - 0,06 g · s<sup>-1</sup>.

5.3

<b>Marking guidelines</b>	
<ul style="list-style-type: none"> <li>Calculate/Bereken: <math>m(\text{CaCO}_3)</math> reacted/reageer or / of <math>V(\text{CO}_2)</math> produced/gevorm. ✓</li> <li>Substitute/Vervang: <math>100 \text{ g} \cdot \text{mol}^{-1}</math>. ✓</li> <li>USE mol ratio/GEBRUIK molverhouding: <math>n(\text{CO}_2) : n(\text{CaCO}_3) = 1 : 1</math> ✓</li> <li>Use of/ /Gebruik van <math>22,4 \text{ dm}^3 \cdot \text{mol}^{-1}</math>. ✓</li> <li>Final answer/Finale antwoord: <math>0,18 \text{ dm}^3</math> (<math>0,1792 \text{ dm}^3</math>) ✓</li> </ul>	
<p><b>OPTION 1/OPSIE 1</b></p> $m(\text{CaCO}_3) = \frac{40}{100} \times 2 \checkmark$ $= 0,8 \text{ g}$ $n(\text{CaCO}_3)_{\text{reacted}} = \frac{m}{M}$ $= \frac{0,8}{100} \checkmark$ $= 8 \times 10^{-3} \text{ mol}$ $n(\text{CO}_2) = n(\text{CaCO}_3) \checkmark$ $= 8 \times 10^{-3} \text{ mol}$ $V(\text{CO}_2) = 8 \times 10^{-3} \times 22,4 \checkmark$ $= 0,18 \text{ dm}^3 \checkmark$	<p><b>OPTION 2/OPSIE 2</b></p> <p>For 2 g antacid/teensuurtablet:</p> $100 \text{ g} \checkmark \text{CaCO}_3 \dots\dots 22,4 \text{ dm}^3 \checkmark \text{CO}_2$ $2 \text{ g CaCO}_3 \dots\dots 0,448 \text{ dm}^3 \checkmark$
	<p>100% <math>\text{CO}_2 \dots\dots 0,448 \text{ dm}^3 \checkmark</math></p> <p>40% <math>\text{CO}_2 \dots\dots 0,18 \text{ dm}^3 \checkmark</math></p> <p><b>OPTION 3/OPSIE 3</b></p> $100\% \text{ CaCO}_3 \dots\dots 2 \text{ g}$ $40\% \dots\dots 0,8 \text{ g} \checkmark$
	$100 \text{ g} \checkmark \dots\dots 1 \text{ mol}$ $0,8 \text{ g} \dots\dots 8 \times 10^{-3} \text{ mol} \checkmark$
	$1 \text{ mol} \dots\dots 22,4 \text{ dm}^3 \checkmark$ $8 \times 10^{-3} \text{ mol} \dots\dots 0,18 \text{ dm}^3 \checkmark$

(5)

5.4

**ANY ONE/ENIGE EEN:**

- Concentration (of acid)/Konsentrasie (van suur) ✓
- Size/mass of tablet/Identical tablet /Type of tablet.  
Grootte/massa van tablet/Identiese tablet./Tipe tablet.
- State of division / Surface area / Toestand van verdeeldheid / reaksieoppervlak.

(1)

5.5

<b>Criteria for conclusion/Riglyne vir gevolgtrekking:</b>	
Dependent [(reaction) rate/time] and independent (temperature) variables correctly identified. Afhanklike [(reaksie)tempo/tyd] en onafhanklike (temperatuur) veranderlikes korrek geïdentifiseer.	✓
Relationship between the independent and dependent variables correctly stated./Verwantskap tussen die afhanklike en onafhanklike veranderlikes korrek genoem.	✓

**Examples/Voorbeelde:**

- Reaction rate ( $\frac{1}{\text{time}}$ ) increases with increase in temperature.  
*Reaksietyempo ( $\frac{1}{\text{time}}$ ) neem toe met toename in temperatuur.*
- Reaction rate ( $\frac{1}{\text{time}}$ ) decreases with decrease in temperature.  
*Reaksietyempo ( $\frac{1}{\text{time}}$ ) neem af met afname in temperatuur.*
- Time taken for reaction decreases when temperature increases.  
*Tyd vir die reaksie neem af wanneer temperatuur toeneem.*
- Time taken for reaction increases when temperature decreases.  
*Tyd vir die reaksie neem toe as temperatuur afneem.*

**IF/INDIEN**

Reaction rate is DIRECTLY proportional to temperature: Max.  $\frac{1}{2}$   
*Reaksietyempo is DIREK eweredig aan temperatuur: Maks.  $\frac{1}{2}$*

(2)

- 5.6
- Increase in temperature increases the average kinetic energy/molecules move faster. /*Toename in temperatuur verhoog die gemiddelde kinetiese energie/molekule beweeg vinniger.* ✓
  - More molecules have enough/sufficient kinetic energy/More molecules have  $E_k > E_a$ . ✓  
*Meer molekule het genoeg/voldoende kinetiese energie/Meer molekule het  $E_k > E_a$ .*
  - More effective collisions per unit time/second. /Frequency of effective collisions increases. ✓  
*Meer effektiewe botsings per eenheidtyd/sekonde./Frekwensie van effektiewe botsings neem toe.*

(3)

5.7 **Marking guidelines/Nasienriglyne**

- For each value of temperature, the CURVE Y must be above the given CURVE. /  
*Vir elke waarde van temperatuur, moet kurwe Y bo die gegewe kurwe wees.* ✓
- CURVE Y must have an increasing rate with an increase in temperature. /  
*KURWE Y moet 'n toenemende tempo het soos die temperatuur toeneem.* ✓

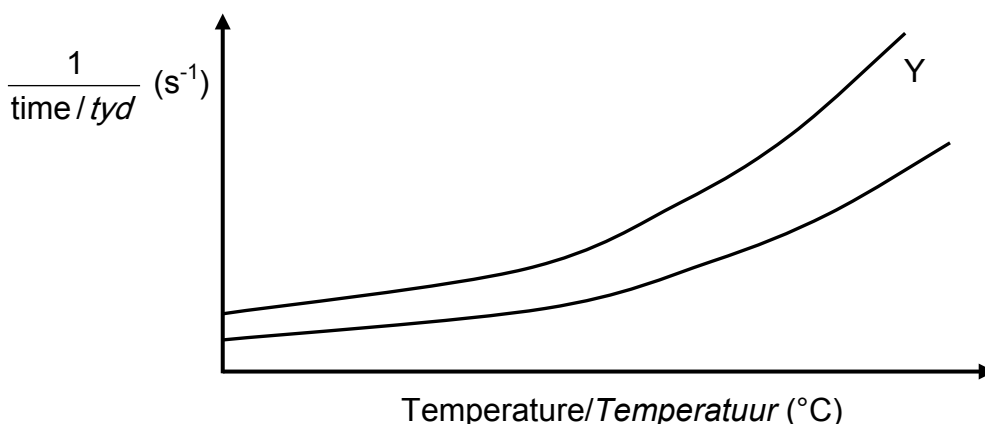

(2)  
**[18]**

### QUESTION 6/VRAAG 6

- 6.1 (The stage in a chemical reaction when the) rate of forward reaction equals the rate of reverse reaction. ✓✓  
(Die stadium in 'n chemiese reaksie wanneer die) tempo van die voorwaartse reaksie gelyk is aan die tempo van die terugwaartse reaksie. (2 or/of 0)

**OR/OF**

- (The stage in a chemical reaction when the) concentrations of reactants and products remain constant.  
(Die stadium in 'n chemiese reaksie wanneer die) konsentrasies van reaktanse en produkte konstant bly. (2 or/of 0) (2)

6.2 **CALCULATIONS USING NUMBER OF MOLES**  
**BEREKENINGE WAT AANTAL MOL GEBRUIK**

6.2.1 **Marking guidelines/Nasienriglyne**

- Substitute/Vervang:  $44 \text{ g} \cdot \text{mol}^{-1}$ . ✓
- Equilibrium concentration of  $\text{CO}_2$  multiply by  $3 \text{ dm}^3$   
*Ewewigskonsentrasie van  $\text{CO}_2$  vermenigvuldig met  $3 \text{ dm}^3$*  } ✓  
**ANDIEN**  $n(\text{CO})_{\text{eq}}$  divide by /deel deur  $3 \text{ dm}^3$
- Use mole ratio/Gebruik molverhouding:  $1:2$  /  $n(\text{CO}) = 2n(\text{CO}_2)$ . ✓
- $n(\text{CO}_2)_{\text{change}} = n(\text{CO}_2)_{\text{initial}} - n(\text{CO}_2)_{\text{final}}$  } ✓  
 $n(\text{CO})_{\text{eq/ewe}} = n(\text{CO})_{\text{initial/begin}} + \Delta n(\text{CO})$  }
- Correct  $K_c$  expression (formulae in square brackets). ✓  
*Korrekte  $K_c$ -uitdrukking (formules in vierkanthakies)*.
- Substitution of concentrations into  $K_c$  expression. ✓  
*Vervanging van konsentrasies in  $K_c$ -uitdrukking*.
- Final answer/Finale antwoord: 12,24 (range/gebied: 11,85 – 12,66) ✓

**OPTION 1/OPSIE 1**

$$n(\text{CO}_2) = \frac{m}{M}$$

$$= \frac{60,8}{44} \checkmark$$

$$= 1,382 \text{ mol}$$

	CO <sub>2</sub>	CO
Initial quantity (mol) <i>Aanvangshoeveelheid (mol)</i>	1,382	0
Change (mol) <i>Verandering (mol)</i>	✓ 1,22	2,44
Quantity at equilibrium (mol)/ <i>Hoeveelheid by ewewig (mol)</i>	0,162	2,44
Equilibrium concentration (mol·dm <sup>-3</sup> ) <i>Ewewigkonsentrasie (mol·dm<sup>-3</sup>)</i>	0,054	0,813

Use ratio/*Gebruik verhouding* ✓Divide/multiply by 3/*Deel/ vermenigvuldig met 3* ✓

$$K_c = \frac{[\text{CO}]^2}{[\text{CO}_2]} \checkmark$$

$$= \frac{(0,813)^2}{0,054} \checkmark$$

$$= 12,24 \checkmark$$

No K<sub>c</sub> expression, correct substitution/*Geen K<sub>c</sub>-uitdrukking, korrekte substitusie*: Max./Maks.  $\frac{6}{7}$ Wrong K<sub>c</sub> expression/*Verkeerde K<sub>c</sub>-uitdrukking*: Max./Maks.  $\frac{4}{7}$ **OPTION 2/OPSIE 2**

$$n(\text{CO}_2) = \frac{m}{M}$$

$$= \frac{60,8}{44} \checkmark$$

$$= 1,382 \text{ mol}$$

$$n(\text{CO}_2)_{\text{change}} = n(\text{CO}_2)_{\text{initial/begin}} - n(\text{CO}_2)_{\text{final/finaal}}$$

$$= 1,382 - 0,162$$

$$= 1,22 \text{ mol}$$

$$n(\text{CO})_{\text{change}} = 2(\text{CO}_2) \checkmark$$

$$= 2(1,22) \checkmark$$

$$= 2,44 \text{ mol}$$

$$n(\text{CO})_{\text{eq}} = n(\text{CO})_{\text{change}} = 2,44 \text{ mol}$$

$$c(\text{CO}) = \frac{n}{V}$$

$$= \frac{2,44}{3} \checkmark$$

$$= 0,813 \text{ mol·dm}^{-3}$$

$$K_c = \frac{[\text{CO}]^2}{[\text{CO}_2]} \checkmark$$

$$= \frac{(0,813)^2}{0,054} \checkmark$$

$$= 12,24 \checkmark \text{ (Accept range/Aanvaar gebied: 11,85 – 12,66).}$$

**CALCULATIONS USING CONCENTRATION**  
**BEREKENINGE WAT KONSENTRASIE GEBRUIK**

**Marking guidelines/Nasienriglyne**

- Substitute 44 g·mol<sup>-1</sup>. ✓
- Initial n(CO<sub>2</sub>) divide by 3 dm<sup>3</sup>. ✓  
*Aanvanklike n(CO<sub>2</sub>) gedeel deur 3 dm<sup>3</sup>.*
- USE** ratio/**GEBRUIK** verhouding: c(CO<sub>2</sub>) : c(CO) = 1 : 2 ✓
- $\Delta c(\text{CO}_2) = c(\text{CO}_2)_{\text{initial/begin}} - c(\text{CO}_2)_{\text{eq/ewe}}$ . ✓  
 $c(\text{CO})_{\text{eq/ewe}} = c(\text{CO})_{\text{initial/begin}} + \Delta c(\text{CO})$ . ✓
- Correct K<sub>c</sub> expression (formulae in square brackets). ✓  
*Korrekte K<sub>c</sub> uitdrukking (formules in vierkanthakies).*
- Substitution of concentrations into K<sub>c</sub> expression. ✓  
*Vervanging van konsentrasies in K<sub>c</sub>-uitdrukking.*
- Final answer/Finale antwoord: 12,15 (range/gebied: 11,85 – 12,66) ✓

**OPTION 3/OPSIE 3**

$$n(\text{CO}_2) = \frac{m}{M}$$

$$= \frac{60,8}{44} \checkmark$$

$$= 1,382 \text{ mol}$$

	CO <sub>2</sub>	CO
Initial concentration (mol·dm <sup>-3</sup> ) <i>Aanvanklike konsentrasie (mol·dm<sup>-3</sup>)</i>	0,4607	0
Change (mol·dm <sup>-3</sup> ) <i>Verandering (mol·dm<sup>-3</sup>)</i>	0,4067	0,813
Equilibrium concentration (mol·dm <sup>-3</sup> ) <i>Ewewigskonsentrasie (mol·dm<sup>-3</sup>)</i>	0,054	0,813

Divide by /Deel deur 3 dm<sup>3</sup> ✓  
ratio ✓  
verhouding

$$K_c = \frac{[\text{CO}]^2}{[\text{CO}_2]} \checkmark$$

$$= \frac{(0,813)^2}{0,054} \checkmark$$

$$= 12,15 \checkmark$$

No K<sub>c</sub> expression, correct substitution/Geen K<sub>c</sub>-uitdrukking, korrekte substitusie: Max./Maks. 6/7

Wrong K<sub>c</sub> expression/Verkeerde K<sub>c</sub>-uitdrukking: Max./Maks. 4/7

(7)

**6.2.2 POSITIVE MARKING FROM Q6.2.1/POSITIEWE NASIEN VANAF V6.2.1**

$$\frac{n(\text{C})_{\text{reacted/reageer}}}{n(\text{CO}_2)_{\text{reacted/reageer}}} =$$

$$= 1,22 \text{ mol} \checkmark$$

$$m(\text{C}) = nM \checkmark$$

$$= 1,22(12) \checkmark$$

$$= 14,64 \text{ g} \checkmark$$

**Marking guidelines**

- USE** mol ratio/ **GEBRUIK** molverhouding: n(C) = n(CO<sub>2</sub>). ✓
- Substitute/Vervang: 12 g·mol<sup>-1</sup>. ✓
- Final answer/Finale antwoord: 14,64 g. ✓

(3)

6.3

6.3.1 Remains the same/*Bly dieselfde* ✓

(1)

6.3.2  Decreases/*Afneem* ✓

- (When pressure is increased) the reaction that leads to the smaller amount/number of moles/volume of gas is favoured. ✓  
*(Wanneer die druk verhoog word,) word die reaksie wat tot die kleiner hoeveelheid/aantal mol/volume gas lei, bevoordeel.*
- The reverse reaction is favoured. / More CO<sub>2</sub> is formed. ✓  
*Die terugwaartse reaksie word bevoordeel./ meer CO<sub>2</sub> word gevorm.*

(3)

6.4

6.4.1  Endothermic/*Endotermies* ✓

- When the temperature increases the mol/percentage CO(g)/product increases/forward reaction is favoured./*Wanneer die temperatuur toeneem, neem die mol/persentasie CO(g)/produk toe/voorwaartse reaksie word bevoordeel.* ✓
- An increase in temperature favours the endothermic reaction/*Toename in temperatuur bevoordeel die endotermiese reaksie.* ✓

(3)

6.4.2

**POSITIVE MARKING FROM Q6.2.1./POSITIEWE NASIEN VANAF V6.2.1.**

**Marking guidelines/Nasienriglyne**

- Calculate total volume/mol of gas at equilibrium/*Bereken totale volume/mol gas by ewewig: 0,162 + 2,44 = 2,606 dm<sup>3</sup> /mol* ✓
- OR/OF**
- Calculate the total concentration at equilibrium/*Bereken die totale konsentrasie by ewewig: 0,054 + 0,813 = 0,867 mol·dm<sup>-3</sup>*
- Calculate percentage of ANY one gas/*Bereken persentasie van ENIGE een gas (CO<sub>2</sub> or/of CO).* ✓
- Final answer/*Finale antwoord: T = 827 °C* ✓

**OPTION 1/OPSIE 1**

$$V_{\text{total eq}} = 0,162 + 2,44 \checkmark$$

$$= 2,606 \text{ dm}^3$$

$$\% \text{ CO}_2 = \frac{0,162}{2,606} \times 100 \checkmark$$

$$= 6,225 \%$$

**OR/OF**

$$\% \text{ CO} = \frac{2,44}{2,606} \times 100 \checkmark$$

$$= 93,63 \%$$

**OPTION 2/OPSIE 2**

$$C_{\text{total eq}} = 0,054 + 0,813$$

$$= 0,867 \text{ mol·dm}^{-3}$$

$$\% \text{ CO}_2 = \frac{0,054}{0,867} \times 100 \checkmark$$

$$= 6,228 \%$$

**OR/OF**

$$\% \text{ CO} = \frac{0,813}{0,867} \times 100 \checkmark$$

$$= 93,77 \%$$

∴ T = 827 °C ✓

(3)

[22]

**QUESTION 7/VRAAG 7**

7.1 Strong (acid)/Sterk (suur) ✓



Large/Groot  $K_a$  value/waarde/  $K_a > 1$  / (HBr) ionises completely/ioniseer volledig ✓

(2)

7.2  $H_2O$  ✓

$Br^-$  ✓

(2)

7.3

7.3.1

**Marking guidelines/Nasienriglyne**

- Formula/Formule:  $c = \frac{n}{V} / n = cV / \frac{c_a \times V_a}{c_b \times V_b} = \frac{n_a}{n_b}$  ✓
- Substitution of/Vervanging van: (0,5)(0,0165)/(0,5)(16,5) ✓
- Use mol ratio/Gebruik molverhouding: 1:1/n(HBr) = n(NaOH) ✓
- Substitute/Vervang:  $V = 0,09 \text{ dm}^3 / 90 \text{ cm}^3$  ✓
- Formula/Formule:  $pH = -\log[H_3O^+]$  ✓
- Substitute  $[H_3O^+]$  in pH formula. ✓
- Final answer/Finale antwoord:  $pH = 1,04$  (range/gebied: 1,036 – 1,05) ✓

**OPTION 1/OPSIE 1**

$$\begin{aligned}
 n(\text{NaOH})_{\text{reacted/reageer}} &= cV \checkmark \\
 &= 0,5(0,0165) \checkmark \\
 &= 0,00825 \text{ mol} \\
 n(\text{HBr})_{\text{excess/oormaat}} &= n(\text{NaOH}) = 0,00825 \text{ mol} \checkmark \\
 c(\text{H}_3\text{O}^+) &= \frac{n}{V} \\
 &= \frac{0,00825}{0,09} \checkmark \\
 &= 0,092 \text{ mol} \cdot \text{dm}^{-3} \\
 pH &= -\log[H_3O^+] \checkmark \\
 &= -\log(0,092) \checkmark \\
 &= 1,04 \checkmark
 \end{aligned}$$

**OPTION 2/OPSIE 2**

$$\begin{aligned}
 \frac{c_a V_a}{c_b V_b} &= \frac{n_a}{n_b} \checkmark \\
 \frac{c_a (90)}{(0,5)(16,5)} &= \frac{1}{1} \checkmark \\
 c_a &= 0,092 \text{ mol} \cdot \text{dm}^{-3} \\
 pH &= -\log[H_3O^+] \checkmark \\
 &= -\log(0,092) \checkmark \\
 &= 1,04 \checkmark
 \end{aligned}$$

(7)

7.3.2

**Marking guidelines/Nasienriglyne**

- Calculate/Bereken  $n(\text{HBr})_{\text{initial/aanvanklik}}$ : substitute/vervang (0,45)(0,09) in  $n = cV$  ✓
- Subtraction/Aftrekking:  
 $n(\text{HBr})_{\text{reacted/reageer}} = n(\text{HBr})_{\text{initial/aanvanklik}} - n(\text{HBr})_{\text{reacted with/reageer met NaOH}}$  ✓✓  
**OR/OF:**  $c(\text{HBr})_{\text{reacted/reageer}} = c(\text{HBr})_{\text{initial/aanvanklik}} - c(\text{H}_3\text{O}^+)_{\text{excess/oormaat}}$
- Use mol ratio/Gebruik molverhouding:  $n(\text{Zn}(\text{OH})_2) : n(\text{HBr}) = 1 : 2$  ✓
- Substitution of/Vervanging van:  $99 \text{ g} \cdot \text{mol}^{-1}$  ✓
- Final answer/Finale antwoord: 1,5964 g (range/gebied: 1,58 – 1,68) ✓

**POSITIVE MARKING FROM Q7.3.1/POSITIEWE NASIEN VANAF V7.3.1**

**OPTION 1/OPSIE 1**

$$n(\text{HBr})_{\text{initial/begin}} = cV$$

$$= (0,45)(0,09) \checkmark$$

$$= 0,0405 \text{ mol}$$

$$n(\text{HBr reacted with/reageer met Zn}(\text{OH})_2) = \underline{0,0405 - 0,00825} \checkmark \checkmark$$

$$= 0,03224 \text{ mol}$$

$$n(\text{Zn}(\text{OH})_2) = \frac{1}{2}n(\text{HBr}) = \frac{1}{2}(0,03224) \checkmark = 0,016125 \text{ mol}$$

$$m(\text{Zn}(\text{OH})_2) = nM$$

$$= (0,016125)(99) \checkmark$$

$$= 1,596 \text{ g} \checkmark$$

**OPTION 2/OPSIE 2**

$$c(\text{HBr}) = 0,45 - 0,092 \checkmark \checkmark$$

$$= 0,358 \text{ mol} \cdot \text{dm}^{-3}$$

$$n(\text{HBr reacted/reageer}) = cV$$

$$= 0,358 \times 0,09 \checkmark$$

$$= 0,0322 \text{ mol}$$

$$n(\text{Zn}(\text{OH})_2) = \frac{1}{2}n(\text{HBr}) = \frac{1}{2}(0,0322) \checkmark = 0,01611 \text{ mol}$$

$$m(\text{Zn}(\text{OH})_2) = nM$$

$$= 0,01611 \times 99 \checkmark$$

$$= 1,595 \text{ g} \checkmark \quad (1,60 \text{ g})$$

(6)  
[17]

**QUESTION 8/VRAAG 8**

8.1 Chemical to electrical/*Chemies na elektries* ✓ (1)

8.2 Provides path for movement of ions./ Completes the circuit./Ensures electrical neutrality in the cell./Restore charge balance. ✓  
*Verskaf pad vir beweging van ione./Voltooi die stroombaan./Verseker elektriese neutraliteit in die sel./Herstel balans van lading.* (1)

8.3 **OPTION 1/OPTION 1**

$$E_{\text{cell}}^{\ominus} = E_{\text{cathode}}^{\ominus} - E_{\text{anode}}^{\ominus} \quad \checkmark$$

$$1,49 = 1,36 - E_{\text{anode}}^{\ominus}$$

$$E_{\text{anode}}^{\ominus} = 1,36 - 1,49$$

$$= -0,13 \text{ (V)} \quad \checkmark$$

X is Pb/Lead/Lood ✓

**Notes/Aantekeninge**

- Accept any other correct formula from the data sheet. /Aanvaar enige ander korrekte formule vanaf gegewensblad.
- Any other formula using unconventional abbreviations, e.g.  $E_{\text{cell}}^{\ominus} = E_{\text{OA}}^{\ominus} - E_{\text{RA}}^{\ominus}$  followed by correct substitutions: /Enige ander formule wat onkonvensionele afkortings gebruik, bv.  $E_{\text{sel}}^{\ominus} = E_{\text{OM}}^{\ominus} - E_{\text{RM}}^{\ominus}$  gevolg deur korrekte vervangings:  $\frac{4}{5}$

**OPTION 2/OPSIE 2**

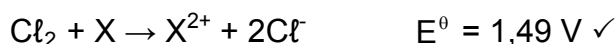

X is Pb/Lead/Lood ✓ (5)

**POSITIVE MARKING FROM Q8.3/POSITIEWE NASIEN VANAF V8.3**

8.4 X/Pb/Lead/Lood ✓ (1)

8.5

8.5.1 Reaction reached equilibrium./ (In each half cell) the rate of oxidation is equal to rate of reduction./Rate of the forward reaction is equal to the rate of the reverse reaction. ✓  
*Reaksie bereik ewewig./ (In elke halfsel) die tempo van oksidasie is gelyk aan tempo van reduksie./Tempo van die voorwaartse reaksie is gelyk aan die tempo van die terugwaartse reaksie.* (1)

8.5.2 Increases/Toeneem ✓ (1)

8.5.3

- $[\text{Cl}^-]$  decreases/neem af. ✓
- Forward reaction is favoured./Voorwaartse reaksie word bevoordeel. ✓

(2)

**[12]**

**QUESTION 9/VRAAG 9**

9.1

**Marking guidelines/Nasienriglyne**

If any one of the underlined key phrases in the **correct context** is omitted, deduct 1 mark. / Indien enige van die onderstreepte frases in die **korrekte konteks** uitgelaat is, trek 1 punt af.

The chemical process in which electrical energy is converted to chemical energy. ✓✓

Die chemiese proses waarin elektriese energie omgeskakel word na chemiese energie.

**OR/OF**

The use of electrical energy to produce a chemical change.

Die gebruik van elektriese energie om 'n chemiese verandering teweeg te bring.

**OR/OF**

The process during which an electrical current passes through a solution/molten ionic compound.

Die proses waar 'n elektriese stroom deur 'n oplossing/gesmelte ioniese verbinding gestuur word.

(2)

9.2

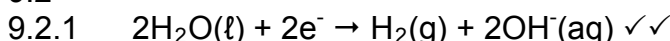

Ignore phases / Ignoreer fases

**Marking guidelines/Nasienriglyne**

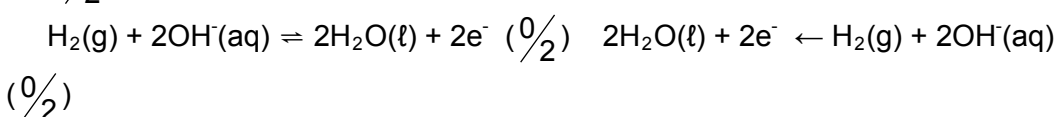
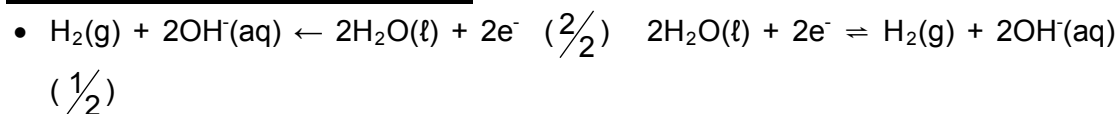

- Ignore if charge omitted on electron. / Ignoreer indien lading weggelaat op elektron.

- If charge (-) omitted on  $\text{OH}^-$  / Indien lading (-) weggelaat op  $\text{OH}^-$ :

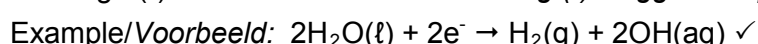

Max. / Maks: 1/2

(2)

9.2.2 Water /  $\text{H}_2\text{O}$  ✓

9.3  $\text{H}_2\text{O}$  is a stronger oxidising agent ✓ than  $\text{Na}^+$  ✓ and will be reduced ✓ (to  $\text{H}_2$ ).  
 $\text{H}_2\text{O}$  is 'n sterker oksideermiddel as  $\text{Na}^+$  en sal gereduseer word (na  $\text{H}_2$ ).

**OR/OF**

$\text{Na}^+$  is a weaker oxidizing agent ✓ than  $\text{H}_2\text{O}$  ✓ and therefore  $\text{H}_2\text{O}$  will be reduced ✓ (to  $\text{H}_2$ )

$\text{Na}^+$  is 'n swakker oksideermiddel as  $\text{H}_2\text{O}$  en daarom sal  $\text{H}_2\text{O}$  gereduseer word (na  $\text{H}_2$ )

**OR/OF**

The half-reaction that produces  $\text{H}_2(\text{g})$  has a more positive reduction potential (-0,83 V) ✓ than the half-reaction that produces Na (-2,71 V). ✓

Therefore water/ $\text{H}_2\text{O}$  will be reduced ✓ to  $\text{H}_2$ . /  $\text{Na}^+$  will not be reduced to Na.

Die halfreaksie wat  $\text{H}_2(\text{g})$  vorm, het 'n meer positiewe reduksiepotensiaal (-0,83 V) as die halfreaksie wat Na vorm (-2,71 V).

Daarom word water/ $\text{H}_2\text{O}$  na  $\text{H}_2$  gereduseer. /  $\text{Na}^+$  sal nie gereduseer word na

(3)

*Na nie.*

**[8]**

### QUESTION 10/VRAAG 10

10.1

10.1.1 Hydrogen/Waterstof/H<sub>2</sub> ✓ (1)

10.1.2 Nitrogen monoxide/Stikstofmonoksied/NO ✓ (1)

10.1.3 Nitric acid/Salpetersuur/HNO<sub>3</sub> ✓ (1)

10.2

10.2.1 (Catalytic) oxidation/Redox/(Katalitiese) oksidasie/Redoks ✓ (1)

10.2.2 NH<sub>3</sub> + HNO<sub>3</sub> ✓ → NH<sub>4</sub>NO<sub>3</sub> ✓ Bal ✓

#### **Notes/Aantekeninge**

- Reactants ✓ Products ✓ Balancing ✓  
Reaktanse Produkte Balansering
- Ignore double arrows (⇌) and phases./Ignoreer dubbelpyle (⇌) en fases.
- Marking rule 6.3.10./Nasienreël 6.3.10.

(3)

10.3

10.3.1 (Total) percentage of nutrients/fertiliser/N,P,K. ✓  
(Totale) persentasie nutriente/ kunsmis/N,P, K. (1)

10.3.2 **Marking guidelines/Nasienriglyne**

- Calculate mass fertiliser in A./Bereken massa kunsmis in A ✓
- Calculate mass fertiliser in B./ Bereken massa kunsmis in B ✓
- Calculate mass P in A and B ./Bereken massa P in A en B✓
- Final answer/Finale antwoord:  
 B has more phosphorous than/het meer fosfor as A. ✓

<p><b>OPTION 1/OPSIE 1</b>                  Mass fertiliser in A:  <i>Massa kunsmis in A:</i>  <math>m = \frac{21}{100} \times 50 \checkmark = 10,5 \text{ kg}</math>                  Mass fertiliser in B:  <i>/Massa kunsmis in B:</i>  <math>m = \frac{27}{100} \times 40 \checkmark = 10,8 \text{ kg}</math>                  Mass phosphorous in A/  <i>Massa fosfor in A:</i>  <math>\frac{3}{8} \times 10,5 = 3,94 \text{ kg}</math>                  Mass phosphorous in B/  <i>Massa fosfor in B:</i>  <math>\frac{3}{8} \times 10,8 = 4,05 \text{ kg}</math>                  Fertiliser B has more phosphorous than fertiliser A. ✓</p>	<p><b>OPTION 3/OPSIE 3</b>                  Mass phosphorous in A/  <i>Massa fosfor in A:</i>  <math>\%P = \frac{3}{8} \times 21 = 7,88\%</math>  <math>m(P) = \frac{7,88}{100} \times 50 \checkmark = 3,94 \text{ kg}</math>                  Mass(P) in B  <i>Massa (P) in B:</i>  <math>\%(P) = \frac{3}{8} \times 27 = 10,13\%</math>  <math>m = \frac{10,13}{100} \times 40 \checkmark = 4,05 \text{ kg}</math>                  Fertiliser B has more phosphorous than fertiliser A. <i>/Kunsmis B het meer fosfor as kunsmis A ✓</i></p>
<p><b>OPTION 2/OPSIE 2</b>                  Mass phosphorous in A/  <i>Massa fosfor in A:</i>  <math>m = \frac{3}{8} \times \frac{21}{100} \times 50 \checkmark = 3,94 \text{ kg}</math>                  Mass(P) in B  <i>Massa (P) in B:</i>  <math>m = \frac{3}{8} \times \frac{27}{100} \times 40 \checkmark = 4,05 \text{ kg}</math>                  Fertiliser B has more phosphorous than fertiliser A. <i>/Kunsmis B het meer fosfor as kunsmis A. ✓</i></p>	<p><b>OPTION 4/OPSIE 4</b>                  Mass fertiliser in A:  <i>Massa kunsmis in A:</i>  <math>m = \frac{21}{100} \times 50 \checkmark = 10,5 \text{ kg}</math>                  Mass fertiliser in B:  <i>/Massa kunsmis in B:</i>  <math>m = \frac{27}{100} \times 40 \checkmark = 10,8 \text{ kg}</math>                  For the same NPK ratio ✓                  the bag with more fertiliser will have more phosphorous ∴ bag B ✓  <i>Vir dieselfde NPK verhouding, die sake met meer kunsmis sal meer fosfor het ∴ sak B</i></p>

(4)  
 [12]

**TOTAL/TOTAAL:**

**150**