



basic education

Department:
Basic Education
REPUBLIC OF SOUTH AFRICA

**NASIONALE
SENIOR SERTIFIKAAT**

GRAAD 12

FISIESE WETENSKAPPE: FISIKA (V1)

NOVEMBER 2017

PUNTE: 150

TYD: 3 uur

Hierdie vraestel bestaan uit 19 bladsye en 3 gegewensblaaie.

INSTRUKSIES EN INLIGTING

1. Skryf jou eksamennummer en sentrumnummer in die toepaslike ruimtes op die ANTWOORDEBOEK.
2. Hierdie vraestel bestaan uit 11 vrae. Beantwoord AL die vrae in die ANTWOORDEBOEK.
3. Begin ELKE vraag op 'n NUWE bladsy in die ANTWOORDEBOEK.
4. Nommer die antwoorde korrek volgens die nommeringstelsel wat in hierdie vraestel gebruik is.
5. Laat EEN reël oop tussen twee subvrae, byvoorbeeld tussen VRAAG 2.1 en VRAAG 2.2.
6. Jy mag 'n nieprogrammeerbare sakrekenaar gebruik.
7. Jy mag toepaslike wiskundige instrumente gebruik.
8. Jy word aangeraai om die aangehegte GEGEWENSBLAAIE te gebruik.
9. Toon ALLE formules en substitusies in ALLE berekeninge.
10. Rond jou FINALE numeriese antwoorde tot 'n minimum van TWEE desimale plekke af.
11. Gee kort (bondige) motiverings, besprekings, ensovoorts waar nodig.
12. Skryf netjies en leesbaar.

VRAAG 1: MEERVOUDIGEKEUSE-VRAE

Verskeie opsies word as moontlike antwoorde op die volgende vrae gegee. Kies die antwoord en skryf slegs die letter (A–D) langs die vraagnommer (1.1–1.10) in die ANTWOORDEBOEK neer, byvoorbeeld 1.11 D.

- 1.1 Die versnelling as gevolg van gravitasie op Aarde is groter as dié op die maan.

Watter EEN van die volgende stellings is KORREK?

- A Die gewig van 'n voorwerp op die Aarde is dieselfde as dié op die maan.
- B Die massa van 'n voorwerp op die Aarde is dieselfde as dié op die maan.
- C Die massa van 'n voorwerp op die Aarde is groter as dié op die maan.
- D Die gewig van 'n voorwerp op die Aarde is minder as dié op die maan. (2)

- 1.2 Die kragtediagram hieronder toon die kragte wat op 'n houer inwerk.

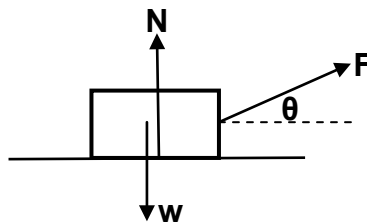

Watter EEN van die volgende vergelykings is KORREK vir die grootte van die normaalkrag (N)?

- A $N = w + F\cos\theta$
- B $N = w + F\sin\theta$
- C $N = w - F\cos\theta$
- D $N = w - F\sin\theta$ (2)

- 1.3 'n Klip word vertikaal opwaarts teen 'n spoed van $v \text{ m}\cdot\text{s}^{-1}$ vanaf die bopunt van 'n gebou geprojekteer. Die posisie-tyd-grafiek hieronder verteenwoordig die beweging van die klip. Ignoreer die effekte van lugweerstand.

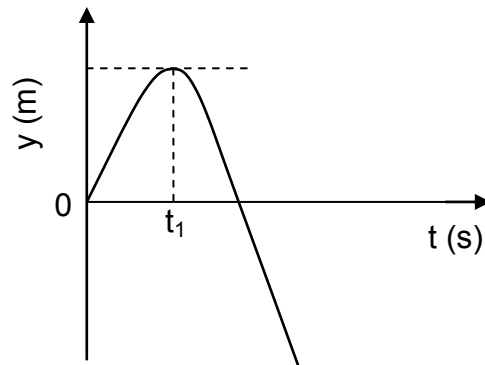

Watter EEN van die kombinasies hieronder oor die groottes van die klip se snelheid en versnelling, by tyd t_1 , is KORREK?

	GROOTTE VAN SNELHEID ($\text{m}\cdot\text{s}^{-1}$)	GROOTTE VAN VERSNELLING ($\text{m}\cdot\text{s}^{-2}$)
A	0	9,8
B	0	0
C	v	0
D	v	9,8

(2)

1.4 'n Trolleie met massa m beweeg teen konstante snelheid v na regs op 'n wrywinglose horisontale oppervlak. 'n Bal klei, ook met massa m , wat vertikaal laat val word, val op die trolleie by tyd t , soos in die diagram hieronder getoon word.

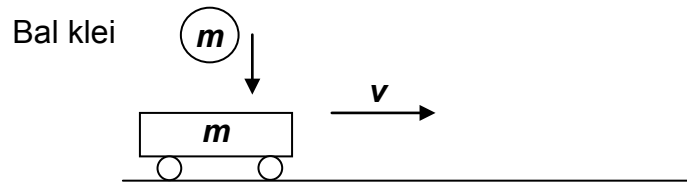

Die bal klei sit aan die trolleie vas.

Watter EEN van die snelheid-tyd-grafieke hieronder is die KORREKTE voorstelling van die snelheid van die trolleie voor en na tyd t ?

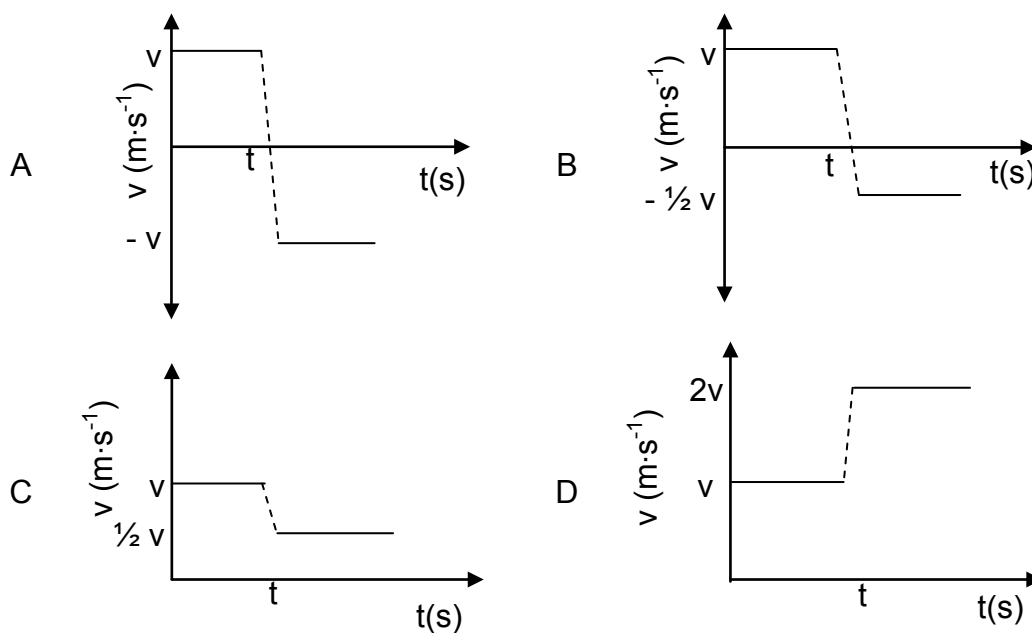

(2)

1.5 'n Persoon lig 'n krat teen konstante snelheid vertikaal opwaarts deur 'n afstand h . Die persoon verrig in tyd t arbeid x op die krat.

Die persoon tel nou dieselfde krat teen konstante snelheid vertikaal opwaarts deur dieselfde afstand, maar in tyd $2t$.

Die arbeid wat die persoon op die krat verrig, sal nou ... wees.

- A $\frac{1}{2}x$
- B x
- C $2x$
- D $4x$

(2)

1.6 Die golflengtes van lig wat deur 'n afgeleë ster uitgestraal word, lyk korter wanneer dit vanaf die Aarde waargeneem word. Hieruit kan ons aflei dat die ster ...

- A na die Aarde toe beweeg en die lig blouverskuiwing ondergaan.
- B na die Aarde toe beweeg en die lig rooiverskuiwing ondergaan.
- C weg van die Aarde af beweeg en die lig rooiverskuiwing ondergaan.
- D weg van die Aarde af beweeg en die lig blouverskuiwing ondergaan. (2)

1.7 Twee identiese ligte grafielbedekte sfere, P_1 en P_2 , word met gebruik van identiese dun geïsoleerde draadjies laat hang. P_1 is gelaai, maar P_2 is neutraal. Die sfere word dan met mekaar in kontak gebring, soos in diagram I getoon. Daarna neem die sfere die posisies in, soos in diagram II getoon.

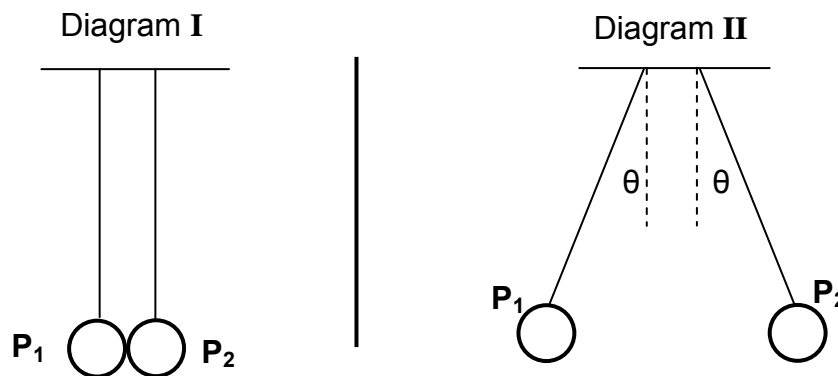

Watter EEN van die volgende stellings oor die ladings op die sfere verduidelik moontlik waarom die sfere weg van mekaar beweeg nadat hulle geraak het, soos in diagram II getoon?

	TEKEN VAN LADING OP P_1	TEKEN VAN LADING OP P_2	GROOTTE VAN LADINGS OP P_1 EN P_2
A	+	+	Ongelyk
B	-	-	Ongelyk
C	+	-	Gelyk
D	+	+	Gelyk

(2)

- 1.8 Wanneer 'n resistor met weerstand R aan 'n battery met emk \mathcal{E} en weglaatbare interne weerstand, verbind word, is die drywing wat in die resistor gelewer word, P .

Indien die resistor vervang word met 'n resistor met weerstand $2R$, sonder om die battery te verander, sal die drywing wat verbruik word ... wees.

A $\frac{1}{4}P$

B $\frac{1}{2}P$

C $2P$

D $4P$

(2)

- 1.9 Die diagram hieronder toon 'n stroomdraende geleier wat in 'n uniforme magneetveld lê wat na regs wys. Die stroom vloei in die bladsy in.

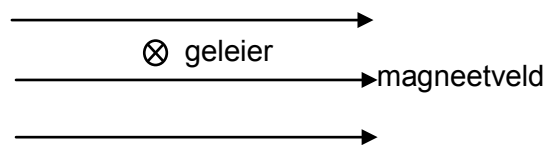

Watter EEN van die volgende pyle toon die rigting van die krag wat deur die geleier ondervind word as gevolg van die magneetveld?



(2)

- 1.10 Lig met 'n sekere frekwensie word op 'n metaal **M** geskyn en elektrone word vanaf die oppervlak vrygestel. Dieselfde ligbron word op 'n ander metaal **N** geskyn.

Die elektrone wat vanaf die oppervlak van metaal **N** vrygestel word, het 'n baie hoër kinetiese energie as dié vanaf metaal **M**.

Dit beteken dat ...

A metaal **N** dieselfde arbeidsfunksie as metaal **M** het.

B metaal **N** 'n groter arbeidsfunksie as metaal **M** het.

C die drumpelfrekwensie van metaal **N** hoër is as dié van metaal **M**.

D die drumpelfrekwensie van metaal **N** laer is as dié van metaal **M**.

(2)
[20]

VRAAG 2 (Begin op 'n nuwe bladsy.)

- 2.1 'n 8 kg-blok, **P**, word teen KONSTANTE SPOED deur konstante krag **F** teen 'n hoek van 30° met die horisontaal teen 'n ruwe skuinsvlak opgetrek.

Krag **F** is parallel aan die skuinsvlak, soos in die diagram hieronder getoon.

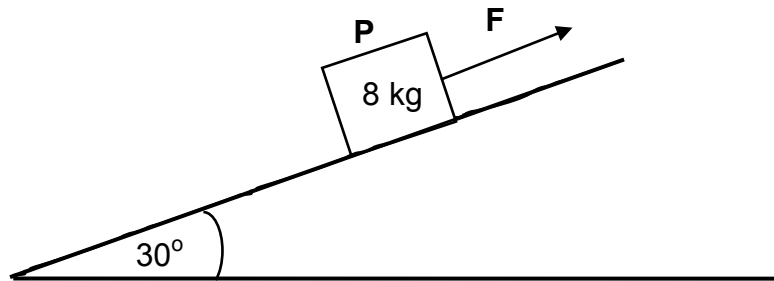

- 2.1.1 Stel Newton se Eerste Wet in woorde. (2)

- 2.1.2 Teken 'n benoemde vrye kragediagram vir blok **P**. (4)

Die kinetiese wrywingskrag tussen die blok en die oppervlak van die skuinsvlak is 20,37 N.

- 2.1.3 Bereken die grootte van krag **F**. (5)

Krag **F** word nou verwyder en die blok VERSNEL teen die helling af. Die kinetiese wrywingskrag bly 20,37 N.

- 2.1.4 Bereken die grootte van die versnelling van die blok. (4)

- 2.2 'n 200 kg-rots lê op die oppervlak van 'n planeet. Die versnelling as gevolg van gravitasie op die oppervlak van die planeet is $6,0 \text{ m}\cdot\text{s}^{-2}$.

- 2.2.1 Stel Newton se Universele Gravitasiewet in woorde. (2)

- 2.2.2 Bereken die massa van die planeet indien sy radius 700 km is. (4)

[21]

VRAAG 3 (Begin op 'n nuwe bladsy.)

Klip **A** word vertikaal opwaarts geprojekteer teen 'n spoed van $12 \text{ m}\cdot\text{s}^{-1}$ vanaf 'n hoogte h bokant die grond. Ignoreer die effekte van lugweerstand.

3.1 Bereken die tyd wat klip **A** neem om sy maksimum hoogte te bereik. (3)

Op dieselfde oomblik wat klip **A** opwaarts geprojekteer word, word klip **B** vanaf dieselfde hoogte met 'n *onbekende spoed*, v , vertikaal afwaarts gegooi. Verwys na die diagram hieronder.

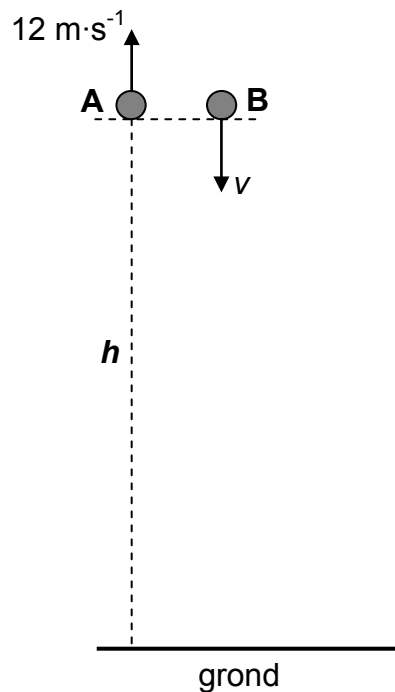

Wanneer klip **A** sy maksimum hoogte bereik, is die spoed van klip **B** $3v$.

3.2 Bereken die spoed, v , waarmee klip **B** afwaarts gegooi word. (4)

Die oomblik wat klip **A** sy aanvanklike posisie op sy pad afwaarts verbysteek, tref klip **B** die grond.

3.3 Bereken die hoogte h . (3)

3.4 Skets snelheid-tyd-grafieke vir die volledige bewegings van klip **A** en **B** op dieselfde assestelsel. Benoem jou grafieke vir klip **A** en **B** duidelik.

Toon die volgende op die grafieke:

- Die tyd wat dit klip **A** neem om sy maksimum hoogte te bereik
- Die snelheid waarmee klip **B** afwaarts gegooi word

(4)
[14]

VRAAG 4 (Begin op 'n nuwe bladsy.)

'n 2 kg-blok in rus op 'n gladde, wrywinglose, horisontale tafel. Die lengte van die blok is x .

'n Koeël met massa 0,015 kg, wat ooswaarts teen $400 \text{ m}\cdot\text{s}^{-1}$ beweeg, tref die blok en beweeg regdeur met konstante versnelling. Verwys na die diagram hieronder. Ignoreer enige verlies van massa van die koeël en die blok.

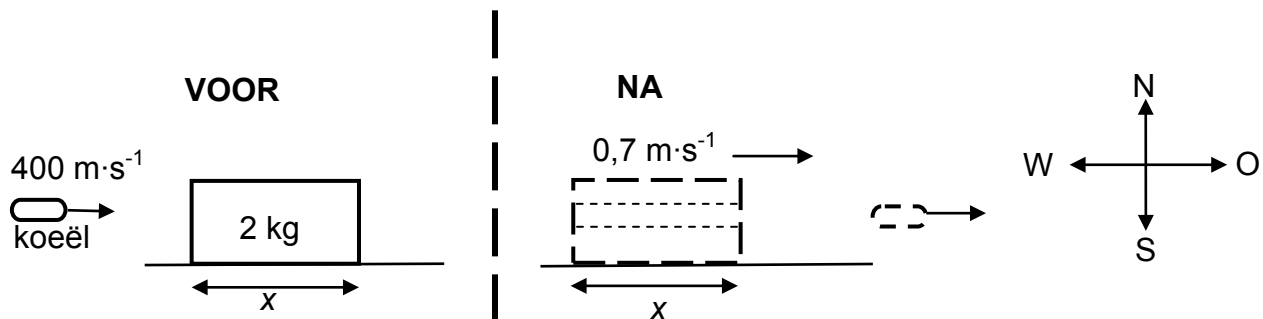

4.1 Stel die *beginsel van behoud van lineêre momentum* in woorde. (2)

Die blok beweeg ooswaarts teen $0,7 \text{ m}\cdot\text{s}^{-1}$ nadat die koeël daaruit te voorskyn gekom het.

4.2 Bereken die grootte van die snelheid van die koeël onmiddellik nadat dit uit die blok te voorskyn kom. (4)

4.3 Indien dit die koeël $0,002 \text{ s}$ neem om deur die blok te beweeg, bereken die lengte, x , van die blok. (5)
[11]

VRAAG 5 (Begin op 'n nuwe bladsy.)

In die diagram hieronder word 'n 4 kg-blok wat op 'n ruwe, horisontale oppervlak lê, aan 'n 6 kg-blok verbind met 'n ligte, onrekbare toutjie wat oor 'n ligte, wrywinglose katrol hang.

Aanvanklik word die blokke IN RUS GEHOU.

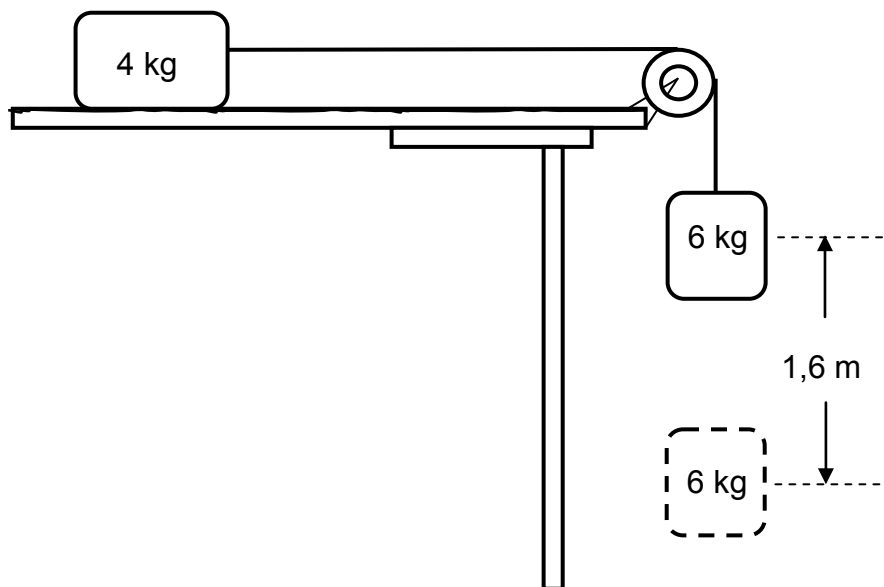

5.1 Stel die arbeid-energie-stelling in woorde. (2)

Wanneer die blokke losgelaat word, val die 6 kg-blok deur 'n vertikale afstand van 1,6 m.

5.2 Teken 'n benoemde vrye kragtediagram vir die 6 kg-blok. (2)

5.3 Bereken die arbeid wat deur die gravitasiekrag op die 6 kg-blok verrig word. (3)

Die kinetiese wrywingskoëffisiënt tussen die 4 kg-blok en die horisontale oppervlak is 0,4. Ignoreer die effekte van lugweerstand.

5.4 Gebruik **energiebeginsels** om die spoed van die 6 kg-blok te bereken wanneer dit deur 1,6 m val, terwyl dit steeds aan die 4 kg-blok verbind is. (5)
[12]

VRAAG 6 (Begin op 'n nuwe bladsy.)

'n Polisiemotor wat teen 'n konstante snelheid beweeg met sy sirene aan, ry verby 'n stilstaande luisteraar.

Die grafiek hieronder toon die veranderinge in die frekwensie van die sirene se klank wat deur die luisteraar waargeneem word.

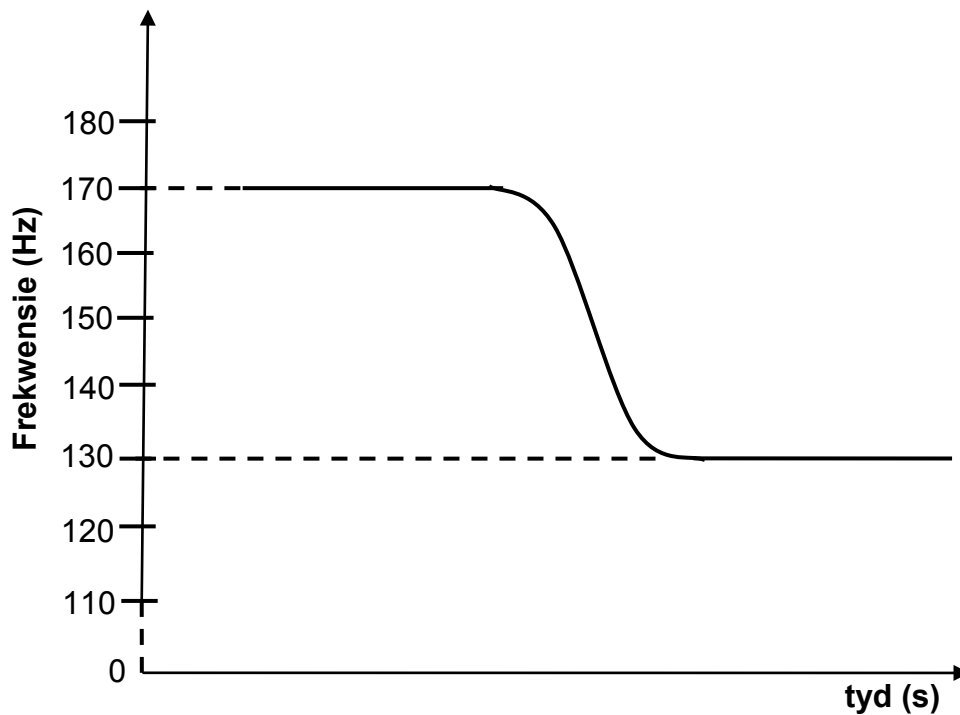

- 6.1 Stel die Doppler-effek in woorde. (2)
- 6.2 Skryf die frekwensie van die klank neer wat deur die luisteraar waargeneem word soos die polisiemotor:
- 6.2.1 Die luisteraar nader (1)
- 6.2.2 Weg van die luisteraar af beweeg (1)
- 6.3 Bereken die spoed van die polisiemotor. Neem die spoed van klank in lug as $340 \text{ m}\cdot\text{s}^{-1}$. (6)
- [10]**

VRAAG 7 (Begin op 'n nuwe bladsy.)

Twee klein sfere, **X** en **Y**, wat ladings van $+6 \times 10^{-6} \text{ C}$ en $+8 \times 10^{-6} \text{ C}$ onderskeidelik dra, word 0,20 m van mekaar af in lug geplaas.

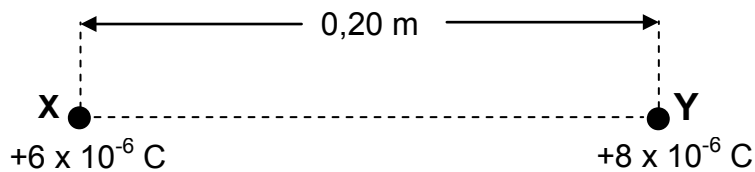

7.1 Stel Coulomb se wet in woorde. (2)

7.2 Bereken die grootte van die elektrostatiese krag wat deur gelaaide sfeer **X** ondervind word. (4)

'n Derde sfeer, **Z**, met 'n onbekende **negatiewe** lading, word nou op 'n afstand van 0,30 m onderkant sfeer **Y** op só 'n manier geplaas dat die lyn wat gelaaide sfeer **X** en **Y** verbind, loodreg is op die lyn wat die gelaaide sfeer **Y** en **Z** verbind, soos in die diagram hieronder getoon.

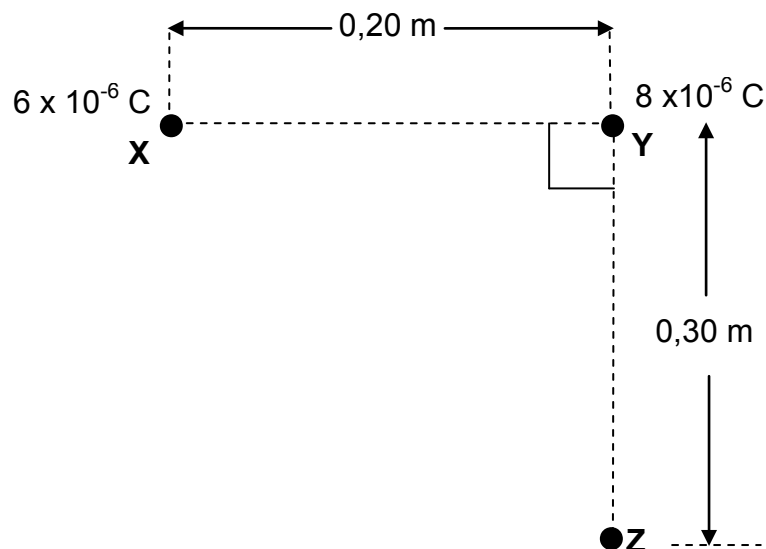

7.3 Teken 'n vektordiagram wat die rigtings van die elektrostatiese kragte en die netto krag toon wat deur gelaaide sfeer **Y** ondervind word as gevolg van die teenwoordigheid van gelaaide sfeer **X** en **Z** onderskeidelik. (3)

7.4 Die grootte van die netto elektrostatiese krag wat deur gelaaide sfeer **Y** ondervind word, is 15,20 N. Bereken die lading op sfeer **Z**. (4)
[13]

VRAAG 8 (Begin op 'n nuwe bladsy.)

A en **B** is twee klein sfere wat deur 'n afstand van 0,70 m van mekaar geskei word. Sfeer **A** dra 'n lading van $+1,5 \times 10^{-6}$ C en sfeer **B** dra 'n lading van $-2,0 \times 10^{-6}$ C.

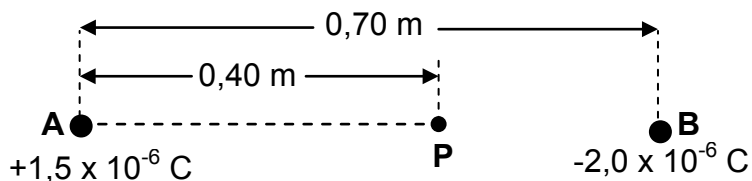

P is 'n punt tussen sfeer **A** en **B** en is 0,40 m vanaf sfeer **A**, soos in die diagram hierbo getoon.

8.1 Definieer die term *elektriese veld by 'n punt*. (2)

8.2 Bereken die grootte van die netto elektriese veld by punt **P**. (4)

8.3 'n Puntlading van grootte $3,0 \times 10^{-9}$ C word nou by punt **P** geplaas.

Bereken die grootte van die elektrostatiese krag wat deur hierdie lading ondervind word. (3)

[9]

VRAAG 9 (Begin op 'n nuwe bladsy.)

- 9.1 Leerders het die verhouding tussen potensiaalverskil (V) en stroom (I) vir die kombinasie van twee resistors, R_1 en R_2 , ondersoek. In een eksperiment is resistor R_1 en R_2 in parallel verbind. In 'n tweede eksperiment is resistor R_1 en R_2 in serie verbind.

Die leerders het toe grafiek **X**, die resultate van een van die eksperimente, en grafiek **Y**, die resultate van die ander eksperiment gestip, soos hieronder getoon.

GRAFIEKE VAN POTENSIAALVERSKIL TEENoor STROOM VIR DIE KOMBINASIE VAN TWEE RESISTORS IN SERIE EN IN PARALLEL

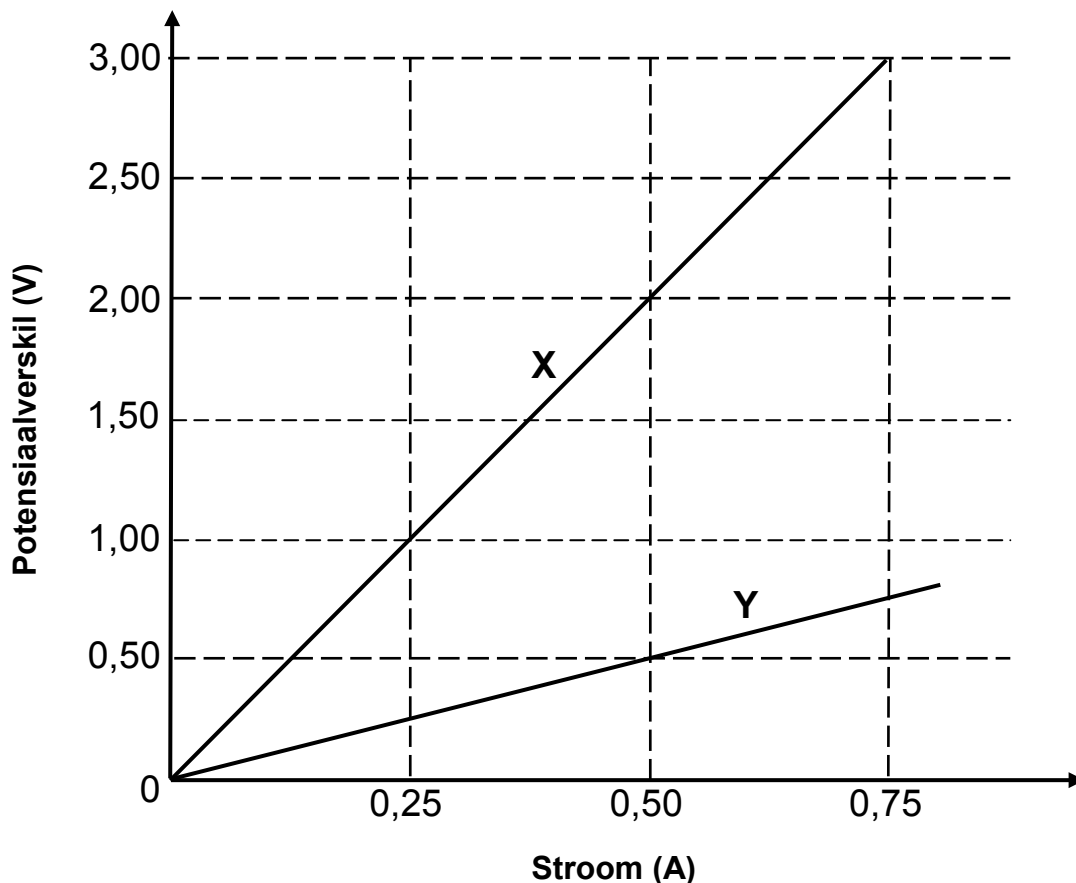

- 9.1.1 Stel Ohm se wet in woorde. (2)
- 9.1.2 Watter fisiese hoeveelheid word deur die gradiënt (helling) van die V-I-grafiek verteenwoordig? (1)
- 9.1.3 Bereken die gradiënt (helling) van grafiek **X**. (2)
- 9.1.4 Bepaal die weerstand van resistor R_1 . (4)

- 9.2 Die stroombaan hieronder bestaan uit drie resistors, **M**, **N** en **T**, 'n battery met emk \mathcal{E} en 'n interne weerstand van $0,9 \Omega$. Die effektiewe weerstand tussen punt **a** en **b** in die stroombaan is 6Ω . Die weerstand van resistor **T** is $1,5 \Omega$.

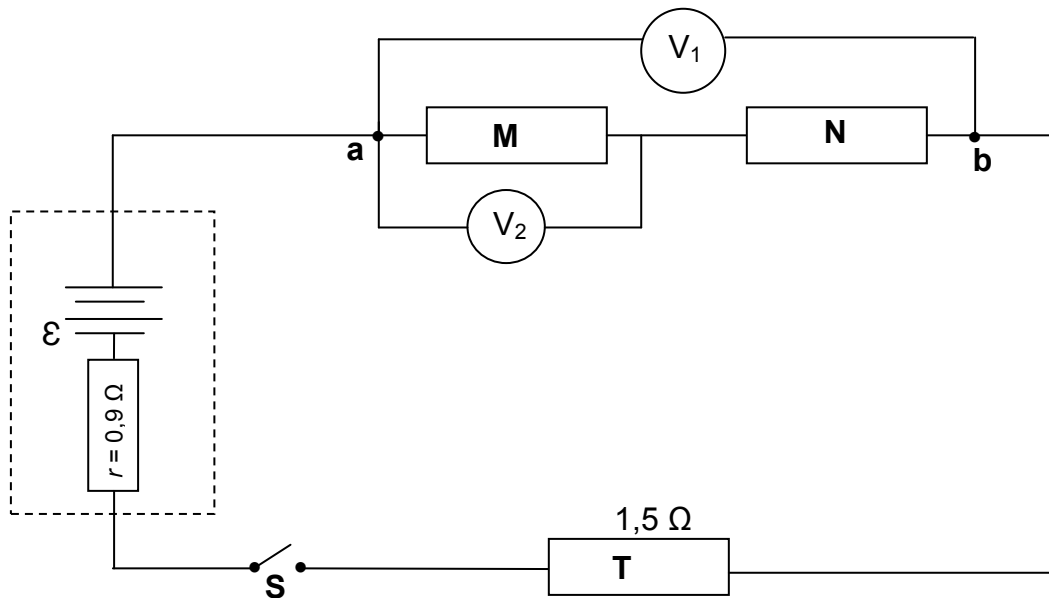

Wanneer skakelaar **S** gesluit is, is die lesing van 'n hoëweerstand-voltmeter, V_1 , oor **a** en **b**, 5 V .

Bereken die:

9.2.1 Stroom wat deur die battery gelewer word (3)

9.2.2 Emk (\mathcal{E}) van die battery (4)

Voltmeter V_2 se lesing is $2,5 \text{ V}$ wanneer die skakelaar gesluit is.

9.2.3 Skryf die weerstand van **N** neer. (Geen berekening is nodig nie.)
Gee 'n rede vir die antwoord.

(2)
[18]

VRAAG 10 (Begin op 'n nuwe bladsy.)

10.1 Die diagram hieronder toon verskillende posisies (**ABCD**) van die lus in 'n **GS**-generator vir 'n volledige omwenteling. Die lus word kloksgewys in 'n uniforme magneetveld teen 'n konstante spoed gedraai.

Die rigting van die magneetveld word in die diagram hieronder getoon.

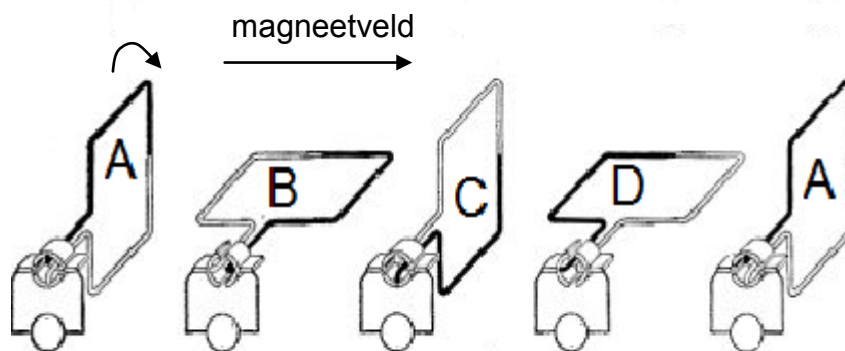

10.1.1 Skryf die energie-omskakeling neer wat tydens die werking van die GS-generator plaasvind. (1)

10.1.2 Skets 'n grafiek om te toon hoe die geïnduseerde emk van die generator met tyd varieer. Dui posisies **A**, **B**, **C**, **D** en **A** duidelik op die grafiek aan. (2)

10.2 'n Klein WS-generator, wat 'n wgk-spanning van 25 V verskaf, word oor 'n toestel met 'n weerstand van 20 Ω verbind. Die drade wat die generator aan die toestel verbind, het 'n totale weerstand van 0,5 Ω. Verwys na die diagram hieronder.

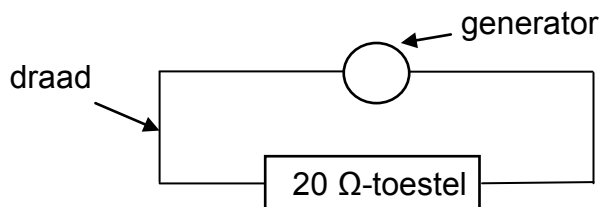

10.2.1 Skryf die totale weerstand van die stroombaan neer. (1)

10.2.2 Bereken die gemiddelde drywing wat aan die *toestel* gelewer word. (5)
[9]

VRAAG 11 (Begin op 'n nuwe bladsy.)

- 11.1 'n Onderwyser in 'n wetenskapklas verduidelik hoe verskillende soorte spektra verkry word. Die onderwyser gebruik die vereenvoudigde diagramme wat hieronder getoon word vir die verduideliking.

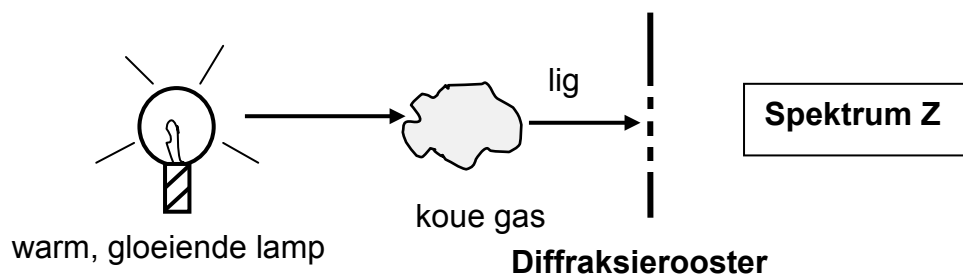
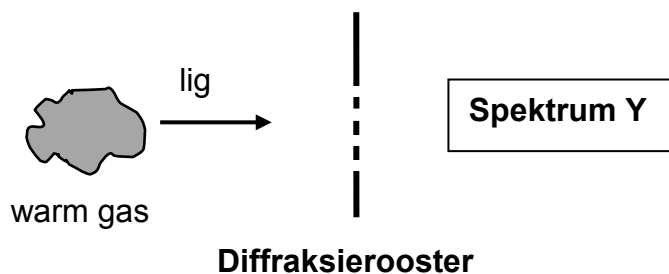

Benoem die soort spektrum by:

11.1.1 **Y** (1)

11.1.2 **Z** (1)

- 11.2 In 'n opgewekte atoom kan elektrone vanaf laer energievlakke na hoër energievlakke 'spring'. Hulle kan ook vanaf hoër energievlakke na laer energievlakke 'val'.

Die diagram hieronder (nie volgens skaal geteken nie) toon enkele oorgange vir elektrone in 'n opgewekte atoom.

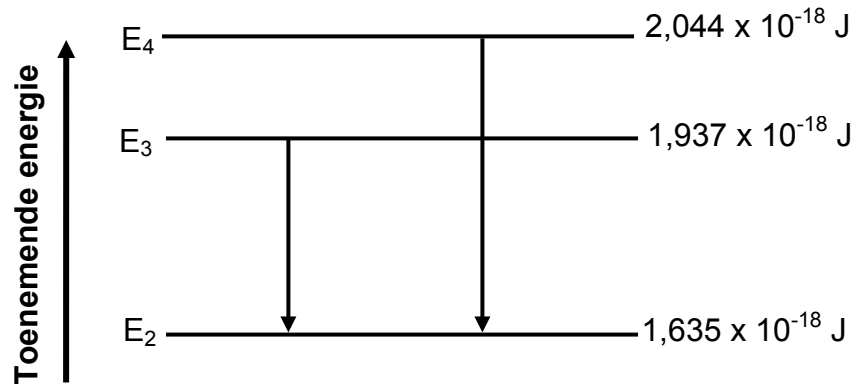

- 11.2.1 Lei die oorgange in die diagram aangedui tot ABSORPSIE- of EMISSIE-spektra? (1)

- 11.2.2 Bereken die frekwensie van die foton wat gevorm word wanneer 'n elektron in 'n opgewekte atoom 'n oorgang vanaf E_4 na E_2 maak, soos in die diagram getoon. (4)

Die drumpelfrekwensie van 'n metaal, Q, is $4,4 \times 10^{14} \text{ Hz}$.

- 11.2.3 Bereken die kinetiese energie van die mees energieke elektron wat vrygestel word wanneer die foton, wat in VRAAG 11.2.2 gevorm is, op die oppervlak van metaal Q inval. (4)

'n Ander metaal, R, het 'n drumpelfrekwensie van $7,5 \times 10^{14} \text{ Hz}$.

- 11.2.4 Sal die foton, wat in VRAAG 11.2.2 gevorm is, elektrone vanaf die oppervlak van metaal R kan vrystel? Skryf slegs JA of NEE.

Gee 'n rede vir die antwoord. (2)
[13]

TOTAAL: 150

**DATA FOR PHYSICAL SCIENCES GRADE 12
PAPER 1 (PHYSICS)**

**GEGEWENS VIR FISIESTE WETENSKAPPE GRAAD 12
VRAESTEL 1 (FISIKA)**

TABLE 1: PHYSICAL CONSTANTS/TABEL 1: FISIESTE KONSTANTES

NAME/NAAM	SYMBOL/SIMBOOL	VALUE/WAARDE
Acceleration due to gravity <i>Swaartekragversnelling</i>	g	9,8 m·s ⁻²
Universal gravitational constant <i>Universele gravitasiekonstante</i>	G	6,67 x 10 ⁻¹¹ N·m ² ·kg ⁻²
Radius of the Earth <i>Radius van die Aarde</i>	R _E	6,38 x 10 ⁶ m
Mass of the Earth <i>Massa van die Aarde</i>	M _E	5,98 x 10 ²⁴ kg
Speed of light in a vacuum <i>Spoed van lig in 'n vakuum</i>	c	3,0 x 10 ⁸ m·s ⁻¹
Planck's constant <i>Planck se konstante</i>	h	6,63 x 10 ⁻³⁴ J·s
Coulomb's constant <i>Coulomb se konstante</i>	k	9,0 x 10 ⁹ N·m ² ·C ⁻²
Charge on electron <i>Lading op elektron</i>	e	-1,6 x 10 ⁻¹⁹ C
Electron mass <i>Elektronmassa</i>	m _e	9,11 x 10 ⁻³¹ kg

TABLE 2: FORMULAE/TABEL 2: FORMULES

MOTION/BEWEGING

$v_f = v_i + a \Delta t$	$\Delta x = v_i \Delta t + \frac{1}{2} a \Delta t^2$ or/of $\Delta y = v_i \Delta t + \frac{1}{2} a \Delta t^2$
$v_f^2 = v_i^2 + 2a\Delta x$ or/of $v_f^2 = v_i^2 + 2a\Delta y$	$\Delta x = \left(\frac{v_i + v_f}{2}\right) \Delta t$ or/of $\Delta y = \left(\frac{v_i + v_f}{2}\right) \Delta t$

FORCE/KRAG

$F_{net} = ma$	$p = mv$
$f_s^{max} = \mu_s N$	$f_k = \mu_k N$
$F_{net} \Delta t = \Delta p$ $\Delta p = mv_f - mv_i$	$w = mg$
$F = G \frac{m_1 m_2}{d^2}$ or/of $F = G \frac{m_1 m_2}{r^2}$	$g = G \frac{M}{d^2}$ or/of $g = G \frac{M}{r^2}$

WORK, ENERGY AND POWER/ARBEID, ENERGIE EN DRYWING

$W = F \Delta x \cos \theta$	$U = mgh$ or/of $E_p = mgh$
$K = \frac{1}{2} mv^2$ or/of $E_k = \frac{1}{2} mv^2$	$W_{net} = \Delta K$ or/of $W_{net} = \Delta E_k$ $\Delta K = K_f - K_i$ or/of $\Delta E_k = E_{kf} - E_{ki}$
$W_{nc} = \Delta K + \Delta U$ or/of $W_{nc} = \Delta E_k + \Delta E_p$	$P = \frac{W}{\Delta t}$
$P_{ave} = Fv_{ave} / P_{gemid} = Fv_{gemid}$	

WAVES, SOUND AND LIGHT/GOLWE, KLANK EN LIG

$v = f \lambda$	$T = \frac{1}{f}$
$f_L = \frac{v \pm v_L}{v \pm v_s} f_s$ $f_L = \frac{v \pm v_L}{v \pm v_b} f_b$	$E = hf$ or/of $E = \frac{hc}{\lambda}$
$E = W_o + E_{k(max)}$ or/of $E = W_o + K_{max}$ where/waar	
$E = hf$ and/en $W_o = hf_o$ and/en $E_{k(max)} = \frac{1}{2} mv_{max}^2$ or/of $K_{max} = \frac{1}{2} mv_{max}^2$	

ELECTROSTATICS/ELEKTROSTATIKA

$F = \frac{kQ_1Q_2}{r^2}$	$E = \frac{kQ}{r^2}$
$V = \frac{W}{q}$	$E = \frac{F}{q}$
$n = \frac{Q}{e}$ or/of $n = \frac{Q}{q_e}$	

ELECTRIC CIRCUITS/ELEKTRIESE STROOMBANE

$R = \frac{V}{I}$	emf (ϵ) = I(R + r) emk (ϵ) = I(R + r)
$R_s = R_1 + R_2 + \dots$ $\frac{1}{R_p} = \frac{1}{R_1} + \frac{1}{R_2} + \dots$	$q = I\Delta t$
$W = Vq$ $W = VI\Delta t$ $W = I^2R\Delta t$ $W = \frac{V^2\Delta t}{R}$	$P = \frac{W}{\Delta t}$ $P = VI$ $P = I^2R$ $P = \frac{V^2}{R}$

ALTERNATING CURRENT/WISSELSTROOM

$I_{rms} = \frac{I_{max}}{\sqrt{2}}$ / $I_{wgk} = \frac{I_{maks}}{\sqrt{2}}$	$P_{ave} = V_{rms} I_{rms}$ / $P_{gemiddeld} = V_{wgk} I_{wgk}$
$V_{rms} = \frac{V_{max}}{\sqrt{2}}$ / $V_{wgk} = \frac{V_{maks}}{\sqrt{2}}$	$P_{ave} = I_{rms}^2 R$ / $P_{gemiddeld} = I_{wgk}^2 R$
	$P_{ave} = \frac{V_{rms}^2}{R}$ / $P_{gemiddeld} = \frac{V_{wgk}^2}{R}$



basic education

Department:
Basic Education
REPUBLIC OF SOUTH AFRICA

**NATIONAL
SENIOR CERTIFICATE
NASIONALE
SENIOR SERTIFIKAAT**

GRADE/GRAAD 12

**PHYSICAL SCIENCES: PHYSICS (P1)
FISIESE WETENSKAPPE: FISIKA (V1)**

NOVEMBER 2017

MARKING GUIDELINES/NASIENRIGLYNE

MARKS/PUNTE: 150

**These marking guidelines consist of 20 pages.
Hierdie nasienriglyne bestaan uit 20 bladsye.**

QUESTION 1 / VRAAG 1

- | | | |
|------|------|-----|
| 1.1 | B ✓✓ | (2) |
| 1.2 | D ✓✓ | (2) |
| 1.3 | A ✓✓ | (2) |
| 1.4 | C ✓✓ | (2) |
| 1.5 | B ✓✓ | (2) |
| 1.6 | A ✓✓ | (2) |
| 1.7 | D ✓✓ | (2) |
| 1.8 | B ✓✓ | (2) |
| 1.9 | C ✓✓ | (2) |
| 1.10 | D ✓✓ | (2) |
- [20]**

QUESTION 2 / VRAAG 2

2.1.1 An object continues in its state of rest or uniform motion (moving with constant velocity) unless it is acted upon by an unbalanced (resultant/net) force. ✓✓

OR

A body will remain in its state of rest or motion at constant velocity unless a resultant/net force acts on it. ✓✓

OR

A body will remain in its state of rest or of uniform motion in a straight line at constant velocity/speed unless a non-zero resultant/net force acts on it. ✓✓

'n Liggaam sal in sy toestand van rus of uniforme beweging (teen konstante snelheid) volhard tensy 'n ongebalanseerde (resulterende/netto) krag daarop inwerk.

OF

'n Liggaam sal in sy toestand van rus of beweging teen konstante snelheid bly tensy 'n resulterende/netto krag daarop inwerk

OF

'n Liggaam sal in sy toestand van rus of uniforme beweging in 'n reguitlyn teen konstante snelheid/spoed volhard tensy 'n nie-nul resulterende/netto krag daarop inwerk.

(2)

2.1.3

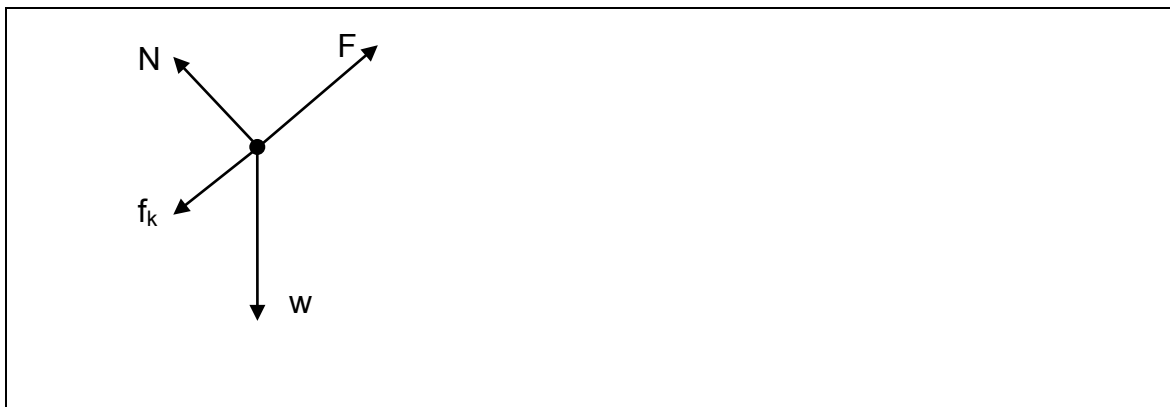

Accepted Labels/Aanvaarde benoemings	
w	F_g / F_w /weight/mg /78,4 N/gravitational force F_g / F_w /gewig/mg/78,4 N/gravitasiekrag
F	F_{app} / F_A / applied force (Accept T / tension) $F_{toegepas}$ / F_T / toegepaste krag (Aanvaar T / spanning)
f_k	(kinetic) Friction/ F_f / f /(kineties) wrywing/ F_w
N	F_N /Normal (force)/Normaal(krag)/ 67,9 N

(4)

2.1.3

$$\begin{aligned}
 F_{\text{net}} &= ma \quad \checkmark \\
 F_{\text{net}} &= 0 \\
 F + (-f_k) + (-F_{\text{gll}}) &= ma \\
 F - (f_k + F_{\text{gll}}) &= ma \\
 F - 20,37 \checkmark - (8)(9,8)\sin 30^\circ \checkmark &= 0 \\
 F &= 59,57 \text{ N} \quad \checkmark
 \end{aligned}$$

(5)

2.1.4

OPTION 1/OPSIE 1	OPTION 2/OPSIE 2
$ \begin{aligned} F_{\text{net}} &= ma \\ (F_{\text{gll}} - f_k) &= ma \\ (8)(9,8)\sin 30^\circ - 20,37 \checkmark &= 8a \checkmark \\ \therefore \text{magnitude/grootte: } a &= 2,35 \text{ m}\cdot\text{s}^{-2} \checkmark \end{aligned} $	$ \begin{aligned} F_{\text{net}} &= ma \\ (f_k - F_{\text{gll}}) &= ma \\ 20,37 + [-(8)(9,8)\sin 30^\circ] \checkmark &= 8a \checkmark \\ \therefore a &= -2,35 \text{ m}\cdot\text{s}^{-2} \\ \therefore \text{magnitude/grootte: } a &= 2,35 \text{ m}\cdot\text{s}^{-2} \checkmark \end{aligned} $

(4)

2.2.1

Each body in the universe attracts every other body with a force that is directly proportional to the product of their masses \checkmark and inversely proportional to the square of the distance between their centres. \checkmark

Elke liggaam in die heelal trek elke ander liggaam aan met 'n krag wat direk eweredig is aan die produk van hul massas en omgekeerd eweredig is aan die kwadraat van die afstand tussen hul middelpunte.

OR/OF

Every particle in the universe attracts every other particle with a force along a line joining them. The force is directly proportional to the product of the masses \checkmark of the particles and inversely proportional to the square of the distance between them. \checkmark

Elke partikel in die heelal trek elke ander partikel aan met 'n krag wat direk eweredig is aan die produk van hul massas en omgekeerd eweredig is aan die kwadraat van die afstand tussen hulle.

(2)

2.2.2

OPTION 1/OPSIE 1	OPTION 2/OPSIE 2
$ \begin{aligned} g &= \frac{GM}{r^2} \quad \checkmark \\ \checkmark 6 &= \frac{(6,67 \times 10^{-11})M}{(700 \times 10^3)^2} \checkmark \\ M &= 4,41 \times 10^{22} \text{ kg} \quad \checkmark \end{aligned} $	$ \begin{aligned} F &= G \frac{m_1 m_2}{r^2} \\ mg &= \frac{GmM}{r^2} \quad \checkmark \\ (200)(6) &= \frac{(6,67 \times 10^{-11})(200)M}{(700 \times 10^3)^2} \checkmark \\ M &= 4,41 \times 10^{22} \text{ kg} \quad \checkmark \end{aligned} $

(4)

[21]

QUESTION 3 / VRAAG 3

3.1

OPTION 1/OPSIE 1	
Upwards positive Opwaarts positief: $v_f = v_i + a\Delta t$ ✓ $0 = (12) + (-9,8)(\Delta t)$ ✓ $\Delta t = 1,22 \text{ s}$ ✓	Downwards positive Afwaarts positief: $v_f = v_i + a\Delta t$ ✓ $0 = (-12) + (9,8)(\Delta t)$ ✓ $\Delta t = 1,22 \text{ s}$ ✓

OPTION 2/OPSIE 2	
Upwards positive Opwaarts positief: $v_f^2 = v_i^2 + 2a\Delta y$ $0 = 12^2 + 2(-9,8)\Delta y$ ✓ $\Delta y = 7,35$ $\Delta y = v_i\Delta t + \frac{1}{2} a\Delta t^2$ ✓ $7,35 = 12\Delta t + \frac{1}{2} (-9,8)\Delta t^2$ $\Delta t = 1,22 \text{ s}$ ✓	Downwards positive Afwaarts positief: $v_f^2 = v_i^2 + 2a\Delta y$ $0 = (-12)^2 + 2(9,8)\Delta y$ ✓ $\Delta y = -7,35$ $\Delta y = v_i\Delta t + \frac{1}{2} a\Delta t^2$ ✓ $-7,35 = -12\Delta t + \frac{1}{2} (9,8)\Delta t^2$ $\Delta t = 1,22 \text{ s}$ ✓

OPTION 3/OPSIE 3	
Upwards positive Opwaarts positief: $v_f^2 = v_i^2 + 2a\Delta y$ $0 = 12^2 + 2(-9,8)\Delta y$ ✓ $\Delta y = 7,35 \text{ m}$ $\Delta x = \left(\frac{v_i + v_f}{2}\right) \Delta t$ ✓ $7,35 = \frac{(12 + 0)}{2} \Delta t$ $\Delta t = 1,22 \text{ s}$ ✓	Downwards positive Afwaarts positief: $v_f^2 = v_i^2 + 2a\Delta y$ $0 = (-12)^2 + 2(9,8)\Delta y$ ✓ $\Delta y = -7,35 \text{ m}$ $\Delta x = \left(\frac{v_i + v_f}{2}\right) \Delta t$ ✓ $-7,35 = \frac{(-12 + 0)}{2} \Delta t$ $\Delta t = 1,22 \text{ s}$ ✓

OPTION 4/OPSIE 4	
$(E_{\text{mech}})_A = (E_{\text{mech}})_{\text{top}}$ $(\frac{1}{2}mv^2 + mgh)_A = (\frac{1}{2}mv^2 + mgh)_{\text{top}}$ $\frac{1}{2}m(12)^2 + 0 = 0 + m(9,8)(h)$ ✓ $\therefore h = \Delta y = 7,35 \text{ m}$	$\Delta x = \left(\frac{v_i + v_f}{2}\right) \Delta t$ ✓ $7,35 = \frac{(12 + 0)}{2} \Delta t$ $\Delta t = 1,22 \text{ s}$ ✓
OR/OF $W_{\text{net}} = \Delta E_k$ $F_{\text{net}}\Delta y \cos\theta = \frac{1}{2}m(v_f^2 - v_i^2)$ $m(9,8)\Delta y \cos 180^\circ = \frac{1}{2}m(0^2 - (12)^2)$ ✓ $\Delta y = 7,35 \text{ m}$	
OR/OF $\Delta E_p + \Delta E_k = 0$ $mg(h_f - h_i) + \frac{1}{2}m(v_f^2 - v_i^2) = 0$ $m(9,8)(h - 0) + \frac{1}{2}(m)(0 - 12^2) = 0$ ✓ $\therefore h = \Delta y = 7,35 \text{ m}$	

OPTION 5/OPSIE 5	
Upwards positive Opwaarts positief: $F_{\text{net}}\Delta t = m(v_f - v_i) \checkmark$ $mg\Delta t = m(v_f - v_i)$ $(-9,8)\Delta t = (0 - 12) \checkmark$ $\Delta t = 1,2245 \text{ s} \checkmark$	Downwards positive Afwaarts positief: $F_{\text{net}}\Delta t = m(v_f - v_i) \checkmark$ $mg\Delta t = m(v_f - v_i)$ $(9,8)\Delta t = (0 - (-12)) \checkmark$ $\Delta t = 1,2245 \text{ s} \checkmark$

OPTION 6/OPSIE 6	
Upwards positive Opwaarts positief: $\Delta y = v_i\Delta t + \frac{1}{2}a\Delta t^2 \checkmark$ $0 = 12\Delta t + \frac{1}{2}(-9,8)\Delta t^2$ $\Delta t = 2,4490 \text{ s}$ $\Delta t = \frac{1}{2}(2,4490) \checkmark$ $= 1,2245 \text{ s} \checkmark$	Downwards positive Afwaarts positief: $\Delta y = v_i\Delta t + \frac{1}{2}a\Delta t^2 \checkmark$ $0 = -12\Delta t + \frac{1}{2}(9,8)\Delta t^2$ $\Delta t = 2,4490 \text{ s}$ $\Delta t = \frac{1}{2}(2,4490) \checkmark$ $= 1,2245 \text{ s} \checkmark$

(3)

3.2

OPTION 1/OPSIE 1

Upwards positive Opwaarts positief: $v_f = v_i + a\Delta t \checkmark$ $-3v = -v \checkmark + (-9,8)(1,22) \checkmark$ $v = 5,98 \text{ m}\cdot\text{s}^{-1} \checkmark (5,978 - 6,03 \text{ m}\cdot\text{s}^{-1})$	Downwards positive Afwaarts positief: $v_f = v_i + a\Delta t \checkmark$ $3v = v \checkmark + (9,8)(1,22) \checkmark$ $v = 5,98 \text{ m}\cdot\text{s}^{-1} \checkmark (5,978 - 6,03 \text{ m}\cdot\text{s}^{-1})$
---	--

OPTION 2/OPSIE 2

Upwards positive Opwaarts positief: $F_{\text{net}}\Delta t = m(v_f - v_i) \checkmark$ $mg\Delta t = m(v_f - v_i)$ $(-9,8)(1,2245) \checkmark = \underline{-3v - (-v)} \checkmark$ $v = 6,00 \text{ m}\cdot\text{s}^{-1} \checkmark$	Downwards positive Afwaarts positief: $F_{\text{net}}\Delta t = m(v_f - v_i) \checkmark$ $mg\Delta t = m(v_f - v_i)$ $(9,8)(1,2245) \checkmark = 3v - v \checkmark$ $v = 6,00 \text{ m}\cdot\text{s}^{-1} \checkmark$
---	--

(4)

3.3

OPTION 1/OPSIE 1

Upwards positive Opwaarts positief: $\Delta y = v_i\Delta t + \frac{1}{2}a\Delta t^2 \checkmark$ $= \underline{(-5,98)(2,44) + \frac{1}{2}(-9,8)(2,44)^2} \checkmark$ $= -43,764$ $\therefore h = 43,76 \text{ m} \checkmark (43,764 - 44,08 \text{ m})$	Downwards positive Afwaarts positief: $\Delta y = v_i\Delta t + \frac{1}{2}a\Delta t^2 \checkmark$ $= \underline{(5,98)(2,44) + \frac{1}{2}(9,8)(2,44)^2} \checkmark$ $= 43,764$ $\therefore h = 43,76 \text{ m} \checkmark (43,764 - 44,08)$
---	--

OPTION 2/OPSIE 2	
<p>Upwards positive Opwaarts positief</p> $v_f = v_i + a\Delta t$ $v_f = -5,98 + (-9,8)(2,44)$ $v_f = -29,892 \text{ m}\cdot\text{s}^{-1}$ $v_f^2 = v_i^2 + 2a\Delta y \checkmark$ $\underline{(-29,892)^2 = (-5,98)^2 + 2(-9,8)\Delta y \checkmark}$ $\Delta y = -43,763 \text{ m}$ $\therefore h = 43,76 \text{ m} \checkmark (43,764 - 44,08)$	<p>Downwards positive Afwaarts positief:</p> $v_f = v_i + a\Delta t$ $v_f = 5,98 + 9,8(2,44)$ $= 29,892 \text{ m}\cdot\text{s}^{-1}$ $v_f^2 = v_i^2 + 2a\Delta y \checkmark$ $\underline{(29,892)^2 = (5,98)^2 + 2(9,8)\Delta y \checkmark}$ $\Delta y = 43,76 \text{ m}$ $\therefore h = 43,76 \text{ m} \checkmark (43,764 - 44,08)$

OPTION 3/OPSIE 3	
<p>Upwards positive Opwaarts positief</p> $v_f = v_i + a\Delta t$ $v_f = -5,98 + (-9,8)(2,44)$ $v_f = -29,892 \text{ m}\cdot\text{s}^{-1}$ $\Delta x = \left(\frac{v_i + v_f}{2} \right) \Delta t \checkmark$ $= \left(\left(\frac{-30 + (-6,00)}{2} \right) (2,4490) \right) \checkmark$ $\Delta x = -44,082 \text{ m}$ $h = 44,082 \text{ m} \checkmark$	<p>Downwards positive Afwaarts positief:</p> $v_f = v_i + a\Delta t$ $v_f = 5,98 + 9,8(2,44)$ $= 29,892 \text{ m}\cdot\text{s}^{-1}$ $\Delta x = \left(\frac{v_i + v_f}{2} \right) \Delta t \checkmark$ $= \left(\left(\frac{30 + 6,00}{2} \right) (2,4490) \right) \checkmark$ $\Delta x = 44,082 \text{ m}$ $h = 44,082 \text{ m} \checkmark$

OPTION 4/OPSIE 4	
<p>Upwards positive Opwaarts positief</p> <p>For A/ Vir A</p> $v_f = v_i + a\Delta t$ $-12 = 12 + (-9,8)\Delta t$ $\Delta t = 2,45 \text{ s}$ <p>For B/ Vir B</p> $\Delta x = v_i\Delta t + \frac{1}{2}a\Delta t^2 \checkmark$ $= \underline{(-5,98)(2,45) + \frac{1}{2}(-9,8)(2,45)^2} \checkmark$ $= -44,06 \text{ m}$ $h = 44,06 \text{ m} \checkmark$	<p>Downwards positive Afwaarts positief:</p> <p>For A/ Vir A</p> $v_f = v_i + a\Delta t$ $12 = -12 + (9,8)\Delta t$ $\Delta t = 2,45 \text{ s}$ <p>For B/ Vir B</p> $\Delta x = v_i\Delta t + \frac{1}{2}a\Delta t^2 \checkmark$ $= \underline{(5,98)(2,45) + \frac{1}{2}(9,8)(2,45)^2} \checkmark$ $= 44,06 \text{ m}$ $h = 44,06 \text{ m} \checkmark$

(3)

OPTION 5/OPSIE 5	
<p>Upwards positive Opwaarts positief</p> $\Delta y = v_i\Delta t + \frac{1}{2}a\Delta t^2 \checkmark$ $\Delta y_A = 12\Delta t + \frac{1}{2}a\Delta t^2$ $\Delta y_B = -6\Delta t + \frac{1}{2}a\Delta t^2$ $\Delta y_A - \Delta y_B = 12\Delta t - (-6\Delta t)$ $0 - \Delta y_B = 18\Delta t \checkmark$ $= 18(2,44)$ $= 43,92 \text{ m}$ $h = 43,92 \text{ m} \checkmark$	<p>Downwards positive Afwaarts positief:</p> $\Delta y = v_i\Delta t + \frac{1}{2}a\Delta t^2 \checkmark$ $\Delta y_A = -12\Delta t + \frac{1}{2}a\Delta t^2$ $\Delta y_B = 6\Delta t + \frac{1}{2}a\Delta t^2$ $\Delta y_A - \Delta y_B = 12\Delta t - (-6\Delta t)$ $0 - \Delta y_B = -18\Delta t \checkmark$ $= -18(2,44)$ $= 43,92 \text{ m}$ $h = 43,92 \text{ m} \checkmark$

(3)

OPTION 6/OPSIE 6	
<p>Upwards positive Opwaarts positief</p> $W_{\text{net}} = \Delta E_k \checkmark$ $mg\Delta y \cos\theta = \frac{1}{2} m(v_f^2 - v_i^2)$ $(-9,8)h \cos 0^\circ = \frac{1}{2} (-20)^2 - \frac{1}{2} (-6)^2 \checkmark$ $h = 44,082 \text{ m} \checkmark$	<p>Downwards positive Afwaarts positief:</p> $W_{\text{net}} = \Delta E_k \checkmark$ $mg\Delta y \cos\theta = \frac{1}{2} m(v_f^2 - v_i^2)$ $(9,8)h \cos 0^\circ = \frac{1}{2} (20)^2 - \frac{1}{2} (6)^2 \checkmark$ $h = 44,082 \text{ m} \checkmark$

OPTION 7/OPSIE 7	
$(E_p + E_k)_{\text{top/bo}} = (E_p + E_k)_{\text{bottom/onder}} \checkmark$ $mgh_i + \frac{1}{2} mv_i^2 = mgh_f + \frac{1}{2} mv_f^2 \checkmark$ $(9,8)h + \frac{1}{2} (6)^2 = (9,8)(0) + \frac{1}{2} (30)^2 \checkmark$ $h = 44,082 \text{ m} \checkmark$	

(3)

3.4

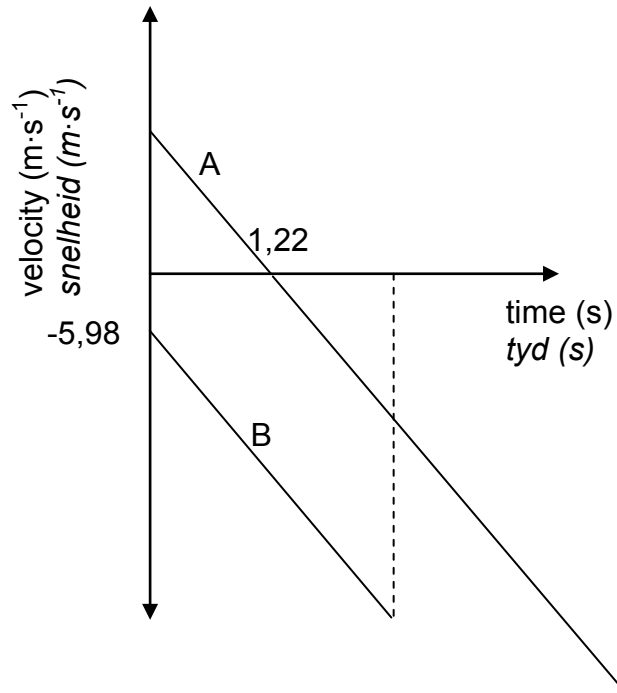
UPWARDS AS POSITIVE/OPWAARTS AS POSITIEF

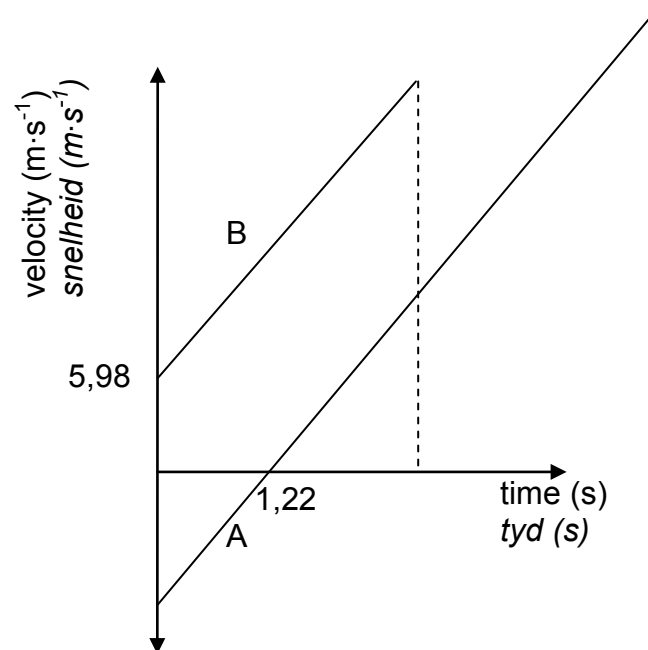
DOWNWARDS AS POSITIVE/AFWAARTS AS POSITIEF

Criteria for graph/Kriteria vir grafiek	Marks/Punte
Time 1,22 s shown correctly /Tyd 1,22 s korrek getoon	✓
Initial velocity for stone B at time t = 0 correctly shown with correct signs / Aanvanklike snelheid vir klip B korrek met korrekte tekens getoon	✓
Two sloping parallel lines with A crossing the time axis / Twee skuins parallelle lyne met A wat die tyd-as kruis	✓
Straight line graph for A parallel to graph B, extending beyond the time when B hits the ground/ Reguitlyn grafiek A parallel aan grafiek B verleng verby die tyd wanneer B die grond tref	✓

(4)
[14]**QUESTION 4 /VRAAG 4**

- 4.1 The total linear momentum in an isolated/closed system is constant. ✓✓
Die totale liniêre momentum in 'n geïsoleerde (geslote) sisteem is konstant

OR/OF

In an isolated/closed system, total linear momentum before collision is equal to total linear momentum after collision. ✓✓

In 'n geïsoleerde (geslote) sisteem is die totale liniêre momentum voor die botsing gelyk aan die totale momentum na die botsing.

(2)

4.2 $\Sigma p_i = \Sigma p_f$ ✓

$$m_B v_{Bi} + m_b v_{bi} = m_B v_{Bf} + m_b v_{bf}$$

$$\Delta p_{\text{bullet}} = -\Delta p_{\text{block}}$$

$$(0,015)(400)✓ + 0 = (0,015)v_{Bf} + 2(0,7)✓$$

$$V_{Bf} = 306,67 \text{ (306,666) m} \cdot \text{s}^{-1} ✓$$

(4)

4.3

OPTION 1/OPSIE 1	
$F_{\text{net}}\Delta t = \Delta p$ $\Delta p = mv_f - mv_i \quad \checkmark$	
For bullet / Vir koeël $\Delta p = (0,015)(306,666 - 400)\checkmark$ $= -1,4 \text{ kg}\cdot\text{m}\cdot\text{s}^{-1}$ $F_{\text{net}}(0,002) = -1,4$ $F_{\text{net}} = -700 \text{ N}$	For block / Vir blok $\Delta p = (2)(0,7 - 0)\checkmark$ $= 1,4 \text{ kg}\cdot\text{m}\cdot\text{s}^{-1}$ $F_{\text{net}}(0,002) = 1,4$ $F_{\text{net}} = 700 \text{ N}$
$W_{\text{net}} = \Delta E_k$ $F_{\text{net}}\Delta x \cos\theta = \frac{1}{2} m(v_f^2 - v_i^2)$ $(700)\Delta x \cos 180^\circ \checkmark = \frac{1}{2} (0,015)(306,67^2 - 400^2)\checkmark$ $\Delta x = 0,71 \text{ m} \checkmark$	
$F_{\text{net}} = ma$ $-700 = (0,015)a$ OR/OF $F_{\text{net}} = ma$ $700 = (0,015)a$ $a = -46\,666,67$ or/of $46\,665 \text{ m}\cdot\text{s}^{-2}$	$\Delta x = v_i\Delta t + \frac{1}{2} a\Delta t^2$ $= (400)(0,002)\checkmark + \frac{1}{2}(-46\,666,67)(0,002)^2\checkmark$ $= 0,71 \text{ m} (0,70667) \text{ m}\checkmark$ OR/OF $v_f^2 = v_i^2 + 2a\Delta x$ $(306,67)^2 \checkmark = \frac{(400)^2}{2} + 2(-46\,666,67)\Delta x\checkmark$ $\Delta x = 0,71 \text{ m} (0,70667) \text{ m} \checkmark$

OPTION 2/OPSIE 2
$v_f = v_i + a\Delta t\checkmark$ $306,666 = 400 + a(0,002)\checkmark$ $a = -46\,667 \text{ m}\cdot\text{s}^{-2}$ $v_f^2 = v_i^2 + 2a\Delta x$ $(306,666)^2 \checkmark = \frac{400^2}{2} + 2(-46667)\Delta x\checkmark$ $\Delta x = 0,71 \text{ m} (0,706 \text{ m}) \checkmark$

OPTION 3/OPSIE 3
$\Delta x = \left(\frac{v_i + v_f}{2} \right) \Delta t \checkmark$ $= \left(\frac{400 + 306,666}{2} \right) (0,002) \checkmark$ $= 0,71 \text{ m} (0,707) \text{ m} \checkmark$

OPTION 4/OPSIE 4

$$W_{\text{net}} = \Delta K / \Delta E_k \checkmark$$

$$F_{\text{net}} \Delta x \cos \theta = ma \Delta x \cos \theta = \Delta K / \Delta E_k$$

$$v_f = v_i + a \Delta t$$

$$306,666 = 400 + a (0,002) \checkmark$$

$$a = -46\,667 \text{ m} \cdot \text{s}^{-2}$$

$$W_{\text{net}} = \Delta K / \Delta E_k$$

$$F_{\text{net}} \Delta x \cos \theta = ma \Delta x \cos \theta = \Delta K / \Delta E_k$$

$$(0,015)(46\,667) \Delta x \cos 180^\circ \checkmark = \frac{1}{2}(0,015)(306,666^2 - 400^2) \checkmark$$

$$\Delta x = 0,71 \text{ m } (0,707) \checkmark$$

OR/OF

$$W_{\text{nc}} = \Delta E_p + \Delta E_k$$

$$(0,015)(46\,667) \Delta x \cos 180^\circ \checkmark = \frac{1}{2}(0,015)(306,666^2 - 400^2) \checkmark$$

$$\Delta x = 0,71 \text{ m } (0,707) \checkmark$$

(5)
[11]**QUESTION 5/VRAAG 5**

- 5.1 The net/total work done (on an object) is equal to the change in the object's kinetic energy. ✓✓

Die netto/totale arbeid wat (op 'n voorwerp) verrig is is gelyk aan die verandering in die voorwerp se kinetiese energie.

OR/OF

The work done on an object by a resultant/net force is equal to the change in the object's kinetic energy. ✓✓

Die arbeid verrig op in voorwerp deur die resultante/netto krag is gelyk aan die verandering in die voorwerp se kinetiese energie.

(2)

- 5.2

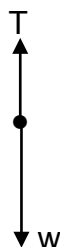

Accepted labels/Aanvaarde benoemings	
w	$F_g / F_w / \text{weight} / mg / 58,8 \text{ N} / \text{gravitational force} / F_{\text{earth on block}}$ $F_g / F_w / \text{gewig} / mg / 58,8 \text{ N} / \text{gravitasiekrag} / F_{\text{aarde op blok}}$
T	$F_T / \text{Tension} / \text{spanning}$

- 5.3

$$\begin{aligned} W_w &= w \Delta x \cos \theta \checkmark \\ &= mg \Delta x \cos \theta \\ &= (6)(9,8)(1,6) \cos 0^\circ \checkmark \\ \therefore W &= 94,08 \text{ J } \checkmark \end{aligned}$$

$$\begin{aligned} W_w &= -\Delta E_p \checkmark \\ &= -mg(h_f - h_i) \\ &= -(6)(9,8)(0 - 1,6) \checkmark \\ &= 94,08 \text{ J } \checkmark \end{aligned}$$

(3)

5.4

OPTION 1/OPSIE 1

$$W_{\text{net}} = \Delta E_K / \Delta K \checkmark = \frac{1}{2}m(v_f^2 - v_i^2)$$

$$W_{\text{net}} = F_{\text{net}}\Delta x \cos\theta$$

$$W_{\text{net}} = W_f + W_g + W_N \\ = \mu_k N \Delta x \cos\theta + W_g + W_N$$

$$W_{\text{net}} = \underline{(0,4)(4)(9,8)(1,6)\cos 180^\circ} \checkmark + 94,08 + 0 \\ = 68,992 \text{ J}$$

$$W_{\text{net}} = \frac{1}{2}m(v_f^2 - v_i^2)$$

$$68,992 \checkmark = \frac{1}{2}(4)(v_f^2 - 0) + \frac{1}{2}(6)(v_f^2 - 0) \checkmark$$

$$v_f = 3,71 \text{ m}\cdot\text{s}^{-1} \checkmark$$

OPTION 2/OPSIE 2

$$W_{\text{nc}} = \Delta E_p + \Delta E_k \checkmark$$

$$f\Delta x \cos\theta = (m_1gh_f - m_1gh_i) + (\frac{1}{2}m_1v_f^2 - \frac{1}{2}m_1v_i^2) + (\frac{1}{2}m_2v_f^2 - \frac{1}{2}m_2v_i^2)$$

$$\underline{(0,4)(4)(9,8)(1,6)\cos 180^\circ} \checkmark = [0 - (6)(9,8)(1,6)] \checkmark + (\frac{1}{2}(6)v_f^2 + \frac{1}{2}(4)v_f^2 - 0) \checkmark$$

$$68,992 = 5v_f^2$$

$$v_f = 3,71 \text{ m}\cdot\text{s}^{-1} \checkmark$$

OPTION 3/OPSIE 3

$$f_k = \mu_k N = (0,4)(4)(9,8) = 15,68 \text{ N}$$

$$T - f_k = ma$$

$$w - T = ma$$

$$T - 15,68 = 4a \dots \text{ (i)}$$

$$(6)(9,8) - T = 6a \dots \text{ (ii)}$$

$$\therefore a = 4,312 \text{ m}\cdot\text{s}^{-2}$$

$$\therefore T = 32,928 \text{ N}$$

$$F_{\text{net}} = ma$$

$$= (6)(4,312)$$

$$= 25,872$$

$$W_{\text{net}} = F_{\text{net}}\Delta x \cos\theta$$

$$= (25,872)(1,6)\cos 0^\circ \checkmark$$

$$= 41,3952 \text{ J}$$

$$W_{\text{net}} = \Delta E_k \checkmark$$

$$41,3952 = \frac{1}{2}m(v_f^2 - v_i^2)$$

$$\underline{41,3952 = \frac{1}{2}(6)(v_f^2 - 0)} \checkmark$$

$$v_f = 3,7146 \text{ m}\cdot\text{s}^{-1} \checkmark$$

Above calculations can be done with 4 kg or 10 kg /
*Bostaande berekeninge kan met 4 kg of 10 kg
gedoen word*

4 kg block

$$W_{\text{net}} = \Delta E_K / \Delta K \checkmark$$

$$W_f + W_T = \frac{1}{2}m(v_f^2 - v_i^2)$$

$$f\Delta x \cos 180^\circ + T\Delta x \cos 0^\circ = \frac{1}{2}(4)(v_f^2 - 0)$$

$$(15,68)(1,6)(-1) \checkmark + (32,928)(1,6)(1) \checkmark = 2v_f^2$$

$$v_f = 3,72 \text{ m}\cdot\text{s}^{-1} \checkmark$$

6 kg block

$$W_{\text{net}} = \Delta E_K / \Delta K \checkmark$$

$$W_w + W_T = \frac{1}{2}m(v_f^2 - v_i^2)$$

$$mg\Delta x \cos 0^\circ + T\Delta x \cos 180^\circ = \frac{1}{2}(6)(v_f^2 - 0)$$

$$(6)(9,8)(1,6)(1) \checkmark + (32,928)(1,6)(-1) \checkmark = 3v_f^2$$

$$v_f = 3,72 \text{ m}\cdot\text{s}^{-1} \checkmark$$

OPTION 4/OPSIE 4

$$W_{\text{net}} = \Delta E_K / \Delta K \checkmark$$

For the 4 kg mass / Vir die 4 kg massa

$$T(1,6)\cos 0^\circ + [(0,4)(9,8)(4)](1,6)\cos 180^\circ \checkmark = \frac{1}{2}(4)v^2 - 0)$$

For the 6 kg mass/Vir die 6 kg massa

$$(6)(9,8)(1,6)\cos 0^\circ + T(1,6)\cos 180^\circ \checkmark = \frac{1}{2}(6)(v^2 - 0)$$

Adding the two equations / Optel van twee vergelykings

$$68,992 = \frac{1}{2}(4)v^2 + \frac{1}{2}(6)v^2 \checkmark$$

$$5v^2 = 68,992$$

$$v = 3,71 \text{ m}\cdot\text{s}^{-1} \checkmark$$

OPTION 5/OPSIE 5

$$W_{\text{net}} = \Delta E_k \checkmark$$

$$F_{\text{net}} \Delta x \cos \theta = \frac{1}{2} m(v_f^2 - v_i^2)$$

$$(F_g - f)\Delta x \cos \theta = \frac{1}{2} m(v_f^2 - v_i^2)$$

$$[(6)(9,8) - (0,4)(4)(9,8)] \checkmark (1,6)\cos 0^\circ \checkmark = \frac{1}{2}(10)(v_f^2 - 0) \checkmark$$

$$v_f = 3,71 \text{ m}\cdot\text{s}^{-1} \checkmark$$

(5)
[12]

QUESTION 6 / VRAAG 6

- 6.1 It is the (apparent) change in frequency (or pitch) of the sound (detected by a listener) ✓ because the sound source and the listener have different velocities relative to the medium of sound propagation. ✓

Dit is die verandering in frekwensie (of toonhoogte) van die klank (waargeneem deur 'n luisteraar) omdat die klankbron en die luisteraar verskillende snelhede relatief tot die medium van klankvoortplanting het.

OR/OF

An (apparent) change in (observed/detected) frequency (pitch), (wavelength) ✓ as a result of the relative motion between a source and an observer ✓ (listener).

'n Skynbare verandering in (waargenome) frekwensie (toonhoogte), (golflengte) as gevolg van die relatiewe beweging tussen die bron en 'n waarnemer / luisteraar.

(2)

6.2.1 170 Hz ✓

(1)

6.2.2 130 Hz ✓

(1)

- 6.3 **POSITIVE MARKING FROM QUESTIONS 6.2.1 and 6.2.2/**

POSITIEWE NASIEN VANAF VRAAG 6.2.1 en 6.2.2

$$f_L = \frac{v \pm v_L}{v \pm v_s} f_s \checkmark$$

$$170 = \frac{(340 + 0)}{(340 - v_s)} \times f_s \text{-----} \textcircled{1}$$

$$130 = \frac{(340 - 0)}{340 + v_s} \times f_s \text{-----} \textcircled{2}$$

$$v_s = 45,33 \text{ m}\cdot\text{s}^{-1} \checkmark (45,33 - 45,45 \text{ m}\cdot\text{s}^{-1})$$

(6)
[10]

QUESTION 7 / VRAAG 7

- 7.1 The magnitude of the electrostatic force exerted by one point charge on another point charge is directly proportional to the product of the (magnitudes of the) charges ✓ and inversely proportional to the square of the distance (r) between them. ✓

Die grootte van die elektrostatiese krag uitgeoefen deur een puntlading op 'n ander puntlading is direk eweredig aan die produk van die (groottes van die) ladings en omgekeerd eweredig aan die kwadraat van die afstand (r) tussen hulle.

OR/OF

The force of attraction or repulsion between two point charges is directly proportional to the product of the charges ✓ and inversely proportional to the square of the distance between them. ✓

Die aantrekkings- of afstotingskrag tussen twee puntladings is direk eweredig aan die produk van die ladings en omgekeerd eweredig aan die kwadraat van die afstand tussen hulle.

(2)

- 7.2

OPTION 1/ OPSIE 1

$$F = k \frac{Q_1 Q_2}{r^2} \checkmark$$

$$= \frac{(9 \times 10^9)(6 \times 10^{-6})(8 \times 10^{-6})}{(0,2)^2} \checkmark$$

$$= 10,8 \text{ N} \checkmark$$

OPTION 2/ OPSIE 2

$$E = \frac{kQ}{r^2} = \frac{(9 \times 10^9)(8 \times 10^{-6})}{(0,2)^2} \checkmark = 1,8 \times 10^4 \text{ N} \cdot \text{C}^{-1}$$

$$F = Eq = (1,8 \times 10^4)(6 \times 10^{-6}) \checkmark = 10,8 \text{ N} \checkmark$$

(4)

- 7.3

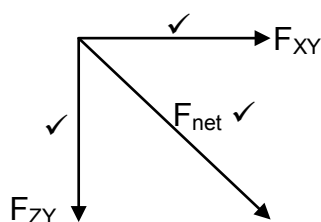

(3)

7.4

OPTION 1 / OPSIE 1

$$F_{\text{net}}^2 = F_{\text{XY}}^2 + F_{\text{ZY}}^2$$

$$15,20^2 = 10,8^2 + F_{\text{ZY}}^2$$

$$F_{\text{ZY}} = 10,696 \text{ N}$$

$$F_{\text{ZY}} = k \frac{Q_Z Q_Y}{r^2}$$

$$10,696 \checkmark = 9 \times 10^9 \times \frac{8 \times 10^{-6} \times Q_Z \checkmark}{(0,30)^2}$$

$$Q_Z = 1,34 \times 10^{-5} \text{ C} \checkmark$$

OPTION 2 / OPSIE 2

$$\cos \theta = \frac{10,8}{15,2}$$

$$\theta = 44,72^\circ$$

$$\sin 44,72 = \frac{F_{\text{ZY}}}{15,2} \checkmark \quad \text{OR/OF} \quad \tan 44,72 = \frac{F_{\text{ZY}}}{F_{\text{XY}}}$$

$$F_{\text{ZY}} = 10,696 \text{ N}$$

$$F_{\text{ZY}} = k \frac{Q_Z Q_Y}{r^2}$$

$$10,696 \checkmark = 9 \times 10^9 \times \frac{8 \times 10^{-6} \times Q_Z \checkmark}{(0,30)^2}$$

$$Q_Z = 1,34 \times 10^{-5} \text{ C} \checkmark$$

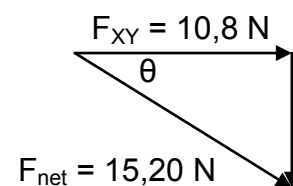
(4)
[13]**QUESTION 8 / VRAAG 8**

8.1 Electric field at a point is the force per unit positive charge placed at that point. $\checkmark \checkmark$

Elektriese veld by 'n punt is die krag per eenheids positiewe lading geplaas by daardie punt.

(2)

8.2

$$E = \frac{kQ}{r^2} \checkmark$$

$$E_{\text{net}} = (E_A + E_B)$$

$$= 9 \times 10^9 \frac{(1,5 \times 10^{-6}) \checkmark}{(0,4)^2} + 9 \times 10^9 \frac{(2,0 \times 10^{-6}) \checkmark}{(0,3)^2}$$

$$= 2,84 \times 10^5 \text{ N} \cdot \text{C}^{-1} \checkmark$$

(4)

8.3

OPTION 1 / OPSIE 1

$$F_E = qE \checkmark$$

$$= (3,0 \times 10^{-9})(2,84 \times 10^5) \checkmark$$

$$= 8,52 \times 10^{-4} \text{ N} \checkmark$$

OPTION 2/OPSIE 2

$$F = \frac{kQ_1Q_2}{r^2} \checkmark$$

$$F_{\text{net}} = (F_A + F_B)$$

$$= \left(\frac{(9 \times 10^9)(3 \times 10^{-6})(1,5 \times 10^{-6})}{(0,4)^2} + \frac{(9 \times 10^9)(3 \times 10^{-6})(2,0 \times 10^{-6})}{(0,3)^2} \right) \checkmark$$

$$= 8,53 \times 10^{-4} \text{ N } \checkmark$$

(3)

[9]**QUESTION 9 / VRAAG 9**

9.1.1 The potential difference (voltage) across a conductor is directly proportional to the current in the conductor at constant temperature. $\checkmark\checkmark$

Die potensiaalverskil (spanning) oor 'n geleier is direk eweredig aan die stroom in die geleier by konstante temperatuur.

OR/OF

The current in a conductor is directly proportional to the potential difference (voltage) across the conductor if temperature is constant. $\checkmark\checkmark$

Die stroom in 'n geleier is direk eweredig aan die potensiaalverskil (spanning) oor die geleier indien die temperatuur konstant is.

(2)

9.1.2 (Equivalent) resistance/ (Ekwivalente) weerstand \checkmark

(1)

9.1.3

$$\begin{aligned} \text{Gradient/Helling} &= \frac{\Delta V}{\Delta I} \\ &= \frac{2-0}{0,5-0} \checkmark = 4 \text{ } (\Omega) \checkmark \end{aligned}$$

(2)

9.1.4 **OPTION 1/OPSIE 1**

In series $R_1 + R_2 = 4 \text{ } \Omega \checkmark \dots\dots\dots(1)$

In parallel $\frac{R_1R_2}{R_1 + R_2} = 1 \text{ } \Omega \checkmark\checkmark \dots\dots\dots(2)$

$$R_1R_2 = 4 \text{ } \Omega$$

$$\therefore R_1 = R_2 = 2 \text{ } \Omega \checkmark$$

OPTION 2/OPSIE 2

For graph X/Vir grafiek X:

$$R_1 + R_2 = 4 \dots\dots\dots(1) \checkmark$$

For graph Y/Vir grafiek Y

$$\frac{1}{R_{//}} = \frac{1}{R_1} + \frac{1}{R_2}$$

$$\left\{ \left(\frac{1}{R_1} + \frac{1}{R_2} \right) = \left(\frac{1}{1} \right) \right\} \checkmark\checkmark \dots\dots\dots(2)$$

$$R_1^2 - 4R_1 + 4 = 0$$

$$R_1 = 2 \text{ } \Omega \checkmark$$

(4)

9.2.1

$$I = \frac{V}{R}$$

$$= \frac{5}{(R_M + R_N)}$$

$$= \frac{5}{(6)} \checkmark$$

$$= 0,83 \text{ A} \checkmark$$

(3)

9.2.2

OPTION 1/OPSIE 1

$$\mathcal{E} = I(R + r) \checkmark$$

$$= 0,83[(6 + 1,5) \checkmark + 0,9 \checkmark]$$

$$= 6,997 \text{ V}$$

$$= 7,(00) \text{ V} \checkmark \quad (6,972 - 7,00 \text{ V})$$

OPTION 2/OPSIE 2

$$\mathcal{E} = (V_s + V_{//} + V_r) \checkmark / V_{\text{ext/eks}} + V_{\text{int}}$$

$$= [5 + (0,833 \times 1,5) \checkmark + (0,9 \times 0,833)] \checkmark$$

$$= 6,999 \text{ V}$$

$$= 7,(00) \text{ V} \checkmark \quad (6,972 - 7,00 \text{ V})$$

9.2.3

The resistance R_N will be 3Ω ✓

The voltage divides (proportionately) in a series circuit. Since the voltage across **M** is half the total voltage, it means the resistances of **M** and **N** are equal. ✓

Die weerstand R_N sal 3Ω wees.

*Die potensiaalverskil verdeel (eweredig) in 'n serie stroombaan. Aangesien die potensiaalverskil oor **M** die helfte is van die totale potensiaalverskil, beteken dit dat die weerstande van **M** en **N** gelyk is.*

(2)

[18]

QUESTION 10 / VRAAG10

10.1

10.1.1 Mechanical to electrical / Meganies na elektries ✓

(1)

10.1.2

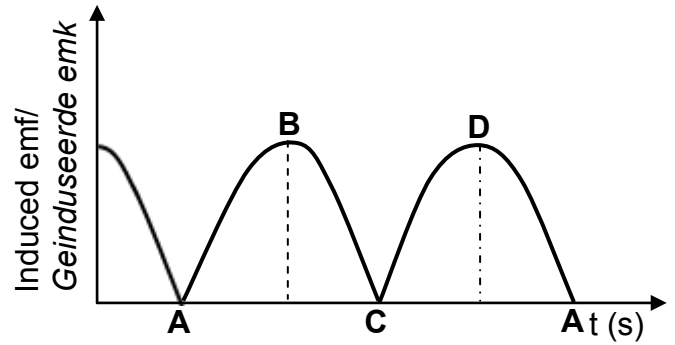
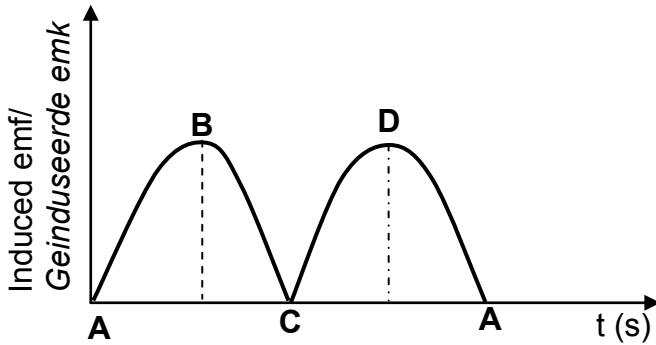

OR/OF

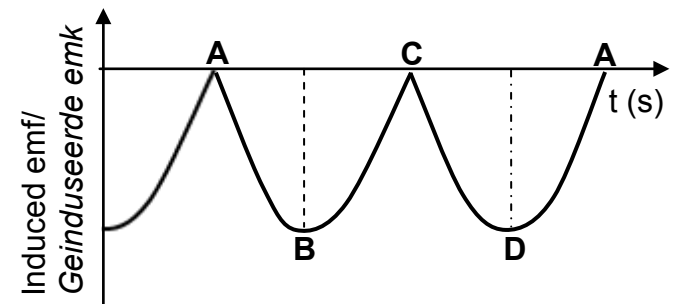
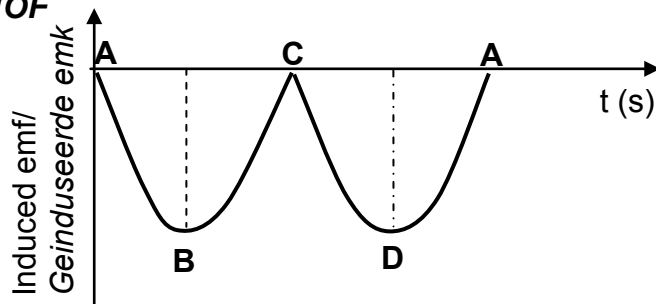

Criteria for graph/Kriteria vir grafiek	Marks/Punte
Correct DC shape, starting from zero/Korrekte GS vorm wat by nul begin	✓
Positions ABCDA correctly indicated on the graph/Posisies ABCDA of grafiek aangedui	✓

(2)

10.2.1 20,5 Ω ✓

(1)

10.2.2 **OPTION 1/OPSIE 1**

$$I_{\text{rms}} = \frac{V_{\text{rms}}}{R} = \frac{25}{20,5} \checkmark$$

$$= 1,22 \text{ (1,2195) A}$$

$$P_{\text{ave}} = I_{\text{rms}}^2 R$$

$$= (1,22)^2 (0,5)$$

$$= 0,74 \text{ W}$$

$$P_{\text{ave}} = \frac{V_{\text{rms}}^2}{R} \checkmark$$

$$P_{\text{ave}} = \frac{(25)^2}{20,5} \checkmark$$

$$P_{\text{ave}} = 30,49 \text{ W}$$

Actual energy delivered per second(power) / *Energie aan toestel gelewer per sekonde (drywing)*

$$= (30,49 - 0,74)$$

$$= 29,75 \text{ W} \checkmark$$

$$P_{\text{ave}} = I_{\text{rms}}^2 R \checkmark$$

$$= (1,22)^2 (20) \checkmark$$

$$= 29,77 \text{ W} \checkmark$$

OR/OF

$$V_{\text{rms/wgk device/toestel}} = \frac{20}{20,5} \checkmark \times 25 = 24,39 \text{ V}$$

$$P_{\text{ave}} = V_{\text{rms}} I_{\text{rms}} \checkmark$$

$$= (24,39)(1,22)$$

$$= 29,76 \text{ W} \checkmark$$

$$W = I_{\text{rms}}^2 R \Delta t$$

$$= (1,22)^2 (0,5)(1)$$

$$= 0,74 \text{ J}$$

$$P_{\text{ave}} = \frac{V_{\text{rms}}^2}{R} \checkmark$$

$$P_{\text{ave}} = \frac{(25)^2}{20,5} \checkmark$$

$$P_{\text{ave}} = 30,49 \text{ W}$$

Actual energy delivered per second(power) / *Energie aan toestel gelewer per sekonde (drywing)*

$$= (30,49 - 0,74)$$

$$= 29,75 \text{ W} \checkmark$$

OPTION 2/OPSIE 2

$$V_{\text{rms/wgk device/toestel}} = \frac{20}{20,5} \checkmark \times 25 = 24,39 \text{ V}$$

$$P_{\text{ave}} = \frac{V_{\text{rms}}^2}{R} = \frac{(24,39)^2}{20} \checkmark = 29,74 \text{ W} \checkmark$$

(5)
[9]**QUESTION 11 / VRAAG 11**11.1.1 (Line) emission (spectrum) / *(Lyn) emissiespektrum* ✓ (1)11.1.2 (Line) absorption (spectrum) / *(Lyn) absorpsiespektrum* ✓ (1)11.2.1 Emission ✓ / *Emissie* (1)11.2.2 Energy released in the transition from E_4 to $E_2 = E_4 - E_2$
Energie vrygestel in die oorgang vanaf E_4 na $E_2 = E_4 - E_2$
 $E_4 - E_2 = (2,044 \times 10^{-18} - 1,635 \times 10^{-18}) \checkmark = 4,09 \times 10^{-19} \text{ J}$

$$E = hf \checkmark$$

$$4,09 \times 10^{-19} = (6,63 \times 10^{-34}) f \checkmark$$

$$f = 6,17 \times 10^{14} \text{ Hz} \checkmark$$

(4)

11.2.3

$$E = W_0 + E_{k(\max)}$$

$$hf = hf_0 + E_{k(\max)}$$

$$hf = hf_0 + \frac{1}{2} m v_{\max}^2$$

$$E = W_0 + \frac{1}{2} m v_{\max}^2$$

✓ Any one/Enige een

$$4,09 \times 10^{-19} \checkmark = (6,63 \times 10^{-34})(4,4 \times 10^{14}) \checkmark + E_{k(\max)}$$

$$E_{k(\max)} = 1,17 \times 10^{-19} \text{ J} \checkmark$$

OR/OF

$$E_{k(\max)} = E_{\text{light/lig}} - W_0 \checkmark$$

$$= hf_{\text{light/lig}} - hf_0 \checkmark$$

✓ Any one/Enige een

$$= (6,63 \times 10^{-34})(6,17 \times 10^{14}) \checkmark - (6,63 \times 10^{-34})(4,4 \times 10^{14}) \checkmark$$

$$= 1,17 \times 10^{-19} \text{ J} \checkmark$$

(4)

11.2.4

No✓ / Nee

The threshold frequency is greater than the frequency of the photon. ✓

*Die drumpelfrekwensie is groter as die frekwensie van die foton***OR/OF**

The frequency of the photon is less than the threshold frequency ✓

*Die frekwensie van die foton is minder as die drumpelfrekwensie***OR/OF**

Energy of the photon is less than the work function of the metal ✓

Energie van foton is minder as die van die arbeidsfunksie van die metaal

(2)

[13]**TOTAL/TOTAAL:****150**