



basic education

Department:
Basic Education
REPUBLIC OF SOUTH AFRICA

NASIONALE SENIOR SERTIFIKAAT

GRAAD 12

FISIESE WETENSKAPPE: CHEMIE (V2)

NOVEMBER 2016

PUNTE: 150

TYD: 3 uur

Hierdie vraestel bestaan uit 18 bladsye en 4 gegewensblaaie.

INSTRUKSIES EN INLIGTING

1. Skryf jou sentrumnommer en eksamennommer in die toepaslike ruimtes op die ANTWOORDEBOEK neer.
2. Hierdie vraestel bestaan uit TIEN vrae. Beantwoord AL die vrae in die ANTWOORDEBOEK.
3. Begin ELKE vraag op 'n NUWE bladsy in die ANTWOORDEBOEK.
4. Nommer die antwoorde korrek volgens die nommeringstelsel wat in hierdie vraestel gebruik is.
5. Laat EEN reël oop tussen twee subvrae, byvoorbeeld tussen VRAAG 2.1 en VRAAG 2.2.
6. Jy mag 'n nieprogrammeerbare sakrekenaar gebruik.
7. Jy mag toepaslike wiskundige instrumente gebruik.
8. Jy word aangeraai om die aangehegte GEGEWENSBLAAIE te gebruik.
9. Toon ALLE formules en substitusies in ALLE berekeninge.
10. Rond jou finale numeriese antwoorde tot 'n minimum van TWEE desimale plekke af.
11. Gee kort (bondige) motiverings, besprekings ensovoorts waar nodig.
12. Skryf netjies en leesbaar.

VRAAG 1: MEERVOUDIGEKEUSE-VRAE

Verskeie opsies word as moontlike antwoorde op die volgende vrae gegee. Skryf die vraagnommer (1.1–1.10) neer, kies die antwoord en maak 'n kruisie (X) oor die letter (A–D) van jou keuse in die ANTWOORDEBOEK.

VOORBEELD:

1.11 A B C D

1.1 In 'n chemiese reaksie sal 'n oksideermiddel ...

A protone verloor.

B protone opneem.

C elektrone verloor.

D elektrone opneem.

(2)

1.2 'n Katalisator word by 'n reaksiemengsel in ewewig gevoeg.

Watter EEN van die volgende stellings oor die effek van die katalisator is ONWAAR?

A Die tempo van die voorwaartse reaksie verhoog.

B Die tempo van die terugwaartse reaksie verhoog.

C Die ewewigsposisie skuif na regs.

D Die ewewigsposisie bly onveranderd.

(2)

1.3 Watter produk sal gevorm word wanneer 'n alkeen in die teenwoordigheid van 'n suurkatalisator met waterdamp (H_2O) reageer?

A Ester

B Alkaan

C Alkohol

D Aldehyd

(2)

1.4 Watter EEN van die volgende stel 'n SUBSTITUSIEREAKSIE voor?

A $CH_2 = CH_2 + HBr \rightarrow CH_3CH_2Br$

B $CH_2 = CH_2 + H_2O \rightarrow CH_3CH_2OH$

C $CH_3CH_2OH \rightarrow CH_2 = CH_2 + H_2O$

D $CH_3CH_2OH + HBr \rightarrow CH_3CH_2Br + H_2O$

(2)

1.5 Beskou die twee organiese molekule **I** en **II** hieronder.

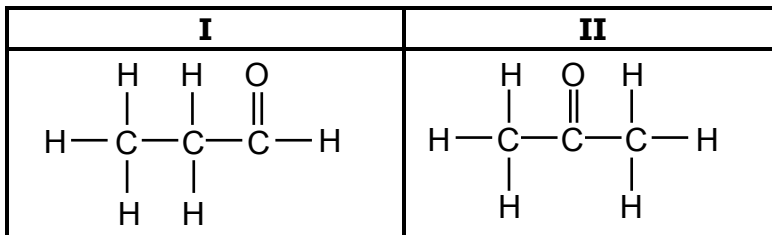

Watter EEN van die volgende verteenwoordig die homoloë reekse waaraan verbinding **I** en verbinding **II** behoort?

	I	II
A	Ketone	Alkohole
B	Aldehiede	Ketone
C	Aldehiede	Alkohole
D	Ketone	Aldehiede

(2)

1.6 Beskou die gebalanseerde vergelykings vir drie reaksies wat hieronder voorgestel word:

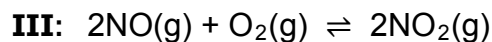
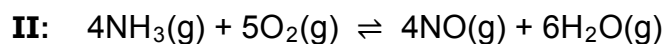
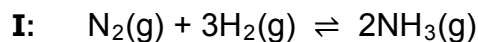

Watter van die reaksies hierbo is 'n deel van die Ostwaldproses?

A Slegs **I**

B Slegs **II**

C Slegs **III**

D Slegs **II** en **III**

(2)

1.7 Watter EEN van die volgende pare is NIE 'n gekonjugeerde suur-basispaar NIE?

A H_3O^+ en OH^-

B NH_4^+ en NH_3

C H_2PO_4^- en HPO_4^{2-}

D H_2CO_3 en HCO_3^-

(2)

- 1.8 Die reaksie tussen waterstofgas en jodiumgas bereik ewewig in 'n geslote houer volgens die volgende gebalanseerde vergelyking:

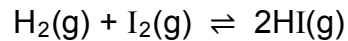

Watter EEN van die grafieke hieronder toon die verwantskap tussen die hoeveelheid HI(g) by ewewig en die druk in die houer by konstante temperatuur?

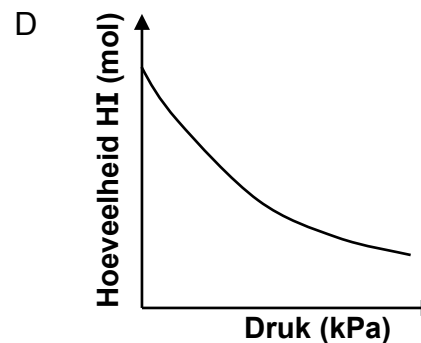
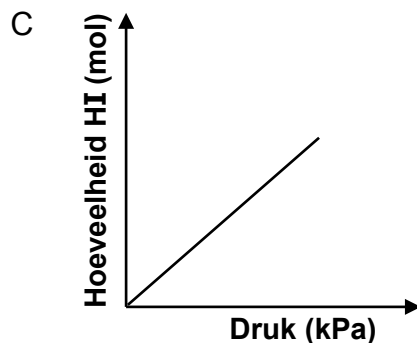
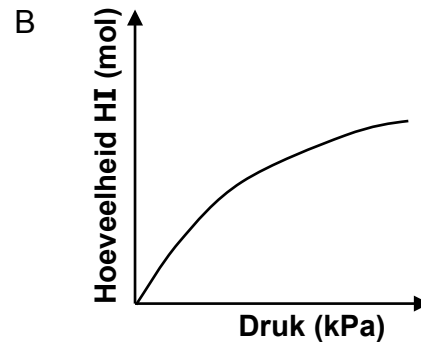
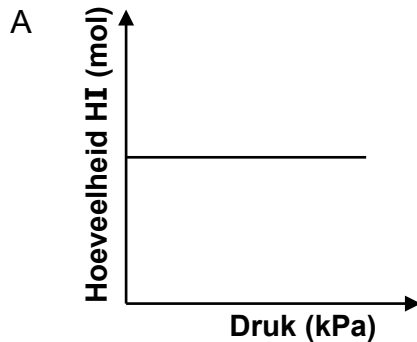

(2)

- 1.9 Watter EEN van die vergelykings hieronder verteenwoordig die halfreaksie wat plaasvind by die KATODE van 'n elektrochemiese sel wat gebruik word om 'n voorwerp te elektroplateer?

- A $\text{Ag} \rightarrow \text{Ag}^+ + \text{e}^-$
 B $\text{Cr}^{3+} + 3\text{e}^- \rightarrow \text{Cr}$
 C $\text{Cr}^{3+} + \text{e}^- \rightarrow \text{Cr}^{2+}$
 D $\text{Cu}^{2+} + \text{e}^- \rightarrow \text{Cu}^+$

(2)

- 1.10 Gelyke hoeveelhede magnesiumpoeier (Mg) reageer onderskeidelik met gelyke volumes en gelyke konsentrasies $\text{HCl}(\text{aq})$ en $\text{H}_2\text{SO}_4(\text{aq})$, soos hieronder getoon.

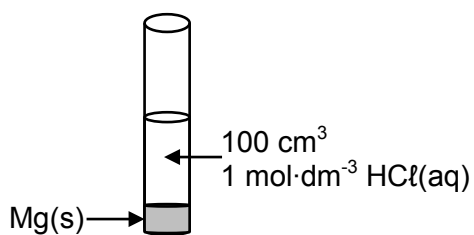
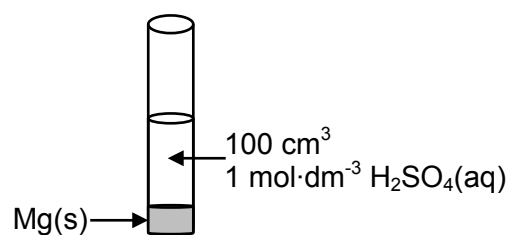
**Proefbuis X****Proefbuis Y**

Magnesium is in OORMAAT.

Beskou die volgende stellings oor hierdie twee reaksies:

- I:** Die aanvanklike tempo van die reaksie in proefbuis **X** is gelyk aan die aanvanklike tempo van die reaksie in proefbuis **Y**.
- II:** Na voltooiing van die reaksies sal die massa magnesium wat in proefbuis **X** oorbly groter wees as dié in proefbuis **Y**.
- III:** Die hoeveelheid waterstofgas wat in **X** gevorm word, is gelyk aan die hoeveelheid waterstofgas wat in **Y** gevorm word.

Watter van die stellings hierbo is WAAR?

- A Slegs **I**
- B Slegs **II**
- C Slegs **III**
- D Slegs **I** en **III**

(2)
[20]

VRAAG 2 (Begin op 'n nuwe bladsy.)

Die letters **A** tot **F** in die tabel hieronder verteenwoordig ses organiese verbindings.

A	$ \begin{array}{c} \text{H} \qquad \qquad \text{H} \\ \qquad \qquad \\ \text{H}-\text{C}-\text{C}=\text{C}-\text{H} \\ \qquad \qquad \\ \text{H} \qquad \qquad \text{H}-\text{C}-\text{H} \\ \\ \text{H} \end{array} $	B	Etieletanoaat
C	2,3-dibromo-3-metielpentaan	D	Poli-eteen
E	$ \begin{array}{c} \text{H} \qquad \text{O} \qquad \qquad \text{H} \\ \qquad \qquad \qquad \\ \text{H}-\text{C}-\text{C}-\text{O}-\text{C}-\text{H} \\ \qquad \qquad \qquad \\ \text{H} \qquad \text{H} \qquad \qquad \text{H} \end{array} $	F	$ \begin{array}{c} \text{H} \qquad \text{H} \qquad \text{H} \qquad \text{O}-\text{H} \\ \qquad \qquad \qquad \\ \text{H}-\text{C}-\text{C}-\text{C}-\text{C}=\text{O} \\ \qquad \qquad \\ \text{H} \qquad \text{H} \qquad \text{H} \end{array} $

2.1 Skryf die LETTER neer wat die volgende verteenwoordig:

- 2.1.1 'n Koolwaterstof (1)
- 2.1.2 'n Funksionele isomeer van verbinding **F** (1)
- 2.1.3 'n Verbinding wat aan dieselfde homoloë reeks as verbinding **B** behoort (1)
- 2.1.4 'n Plastiek (1)

2.2 Skryf die STRUKTUURFORMULE van ELK van die volgende neer:

- 2.2.1 Verbinding **C** (3)
- 2.2.2 Die suur wat gebruik word om verbinding **B** te berei (2)
- 2.2.3 Die monomeer wat gebruik word om verbinding **D** te berei (2)

2.3 Verbinding **A** reageer met 'n onbekende reaktans, **X**, om 2-metielpropan te vorm.

Skryf neer die:

- 2.3.1 NAAM van reaktans **X** (1)
- 2.3.2 Soort reaksie wat plaasvind (1)

[13]

VRAAG 3 (Begin op 'n nuwe bladsy.)

Die kookpunte van drie isomere word in die tabel hieronder gegee.

	ISOMERE	KOOKPUNT (°C)
A	2,2-dimetieselpropan	9
B	2-metieselbutaan	28
C	pentaan	36

- 3.1 Definieer die term *struktuurisomeer*. (2)
- 3.2 Watter soort isomere (POSISIE, KETTING of FUNKSIONEEL) is hierdie drie verbindings? (1)
- 3.3 Verduidelik die neiging in die kookpunte van verbinding **A** na verbinding **C**. (3)
- 3.4 Watter EEN van die drie verbindings (**A**, **B** of **C**) het die hoogste dampdruk? Verwys na die data in die tabel om 'n rede vir die antwoord te gee. (2)
- 3.5 Gebruik MOLEKULÊRE FORMULES en skryf 'n gebalanseerde vergelyking vir die volledige verbranding van verbinding **B**. (3)

[11]

VRAAG 4 (Begin op 'n nuwe bladsy.)

Butaan (C_4H_{10}) word in die nywerheid deur die **TERMIESE** kraging van langketting-koolwaterstofmolekule berei, soos in die vergelyking hieronder getoon. **X** verteenwoordig 'n organiese verbinding wat gelewer word.

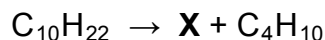

4.1 Skryf neer:

4.1.1 EEN toestand wat nodig is sodat **TERMIESE** kraging kan plaasvind (1)

4.1.2 Die molekulêre formule van verbinding **X** (1)

4.1.3 Die homoloë reeks waaraan verbinding **X** behoort (1)

4.2 'n Mengsel van twee gasse, verbinding **X** en butaan, word deur broomwater, $Br_2(aq)$, in 'n koniese fles geborrel soos hieronder geïllustreer. **DIE REAKSIE WORD IN 'N DONKER VERTREK UITGEVOER.**

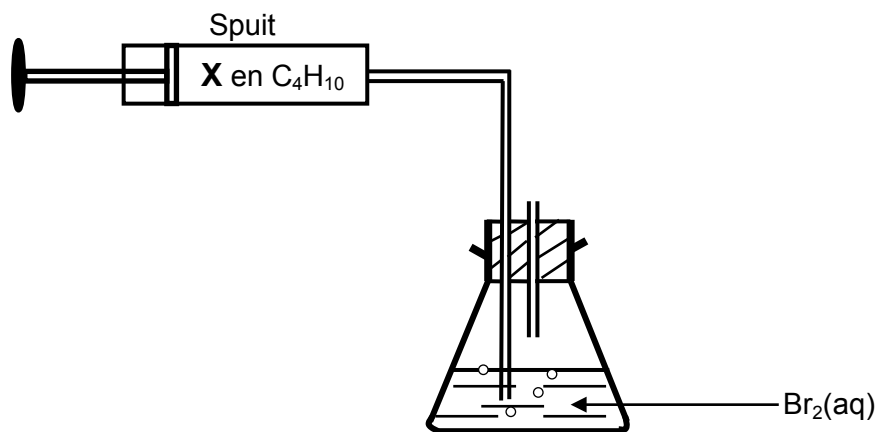

Die kleur van die broomwater verander van rooibruin na kleurloos wanneer die mengsel van die twee gasse daardeur geborrel word.

Watter EEN van die gasse (**X** of **BUTAAN**) ontkleur die broomwater? Verduidelik die antwoord. (4)

- 4.3 Bestudeer die vloediagram hieronder wat verskillende organiese reaksies voorstel, en beantwoord die vrae wat volg.

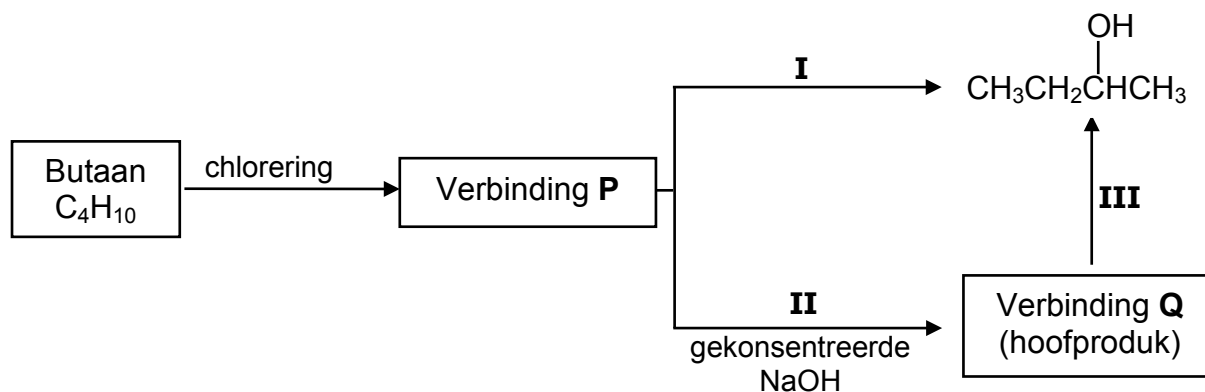

Skryf neer die:

- 4.3.1 IUPAC-naam van verbinding **P** (2)
- 4.3.2 Soort reaksie wat **I** gemerk is (1)
- 4.3.3 Struktuurformule van verbinding **Q** (2)
- 4.3.4 Die tipe addisiereaksie wat deur reaksie **III** verteenwoordig word (1)

[13]

VRAAG 5 (Begin op 'n nuwe bladsy.)

Waterstofperoksied, H_2O_2 , ontbind om water en suurstof volgens die volgende gebalanseerde vergelyking te lewer:

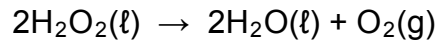

5.1 Die aktiveringsenergie (E_A) vir hierdie reaksie is 75 kJ en die reaksiewarmte (ΔH) is -196 kJ.

5.1.1 Definieer die term *aktiveringsenergie*. (2)

5.1.2 Teken die assestelsel hieronder in jou ANTWOORDEBOEK oor en voltooi dan die potensiele-energiediagram vir hierdie reaksie.

Dui die waarde van die potensiele energie van die volgende op die y-as aan:

- Geaktiveerde kompleks
- Produkte

(Die grafiek hoef NIE volgens skaal geteken te word NIE.)

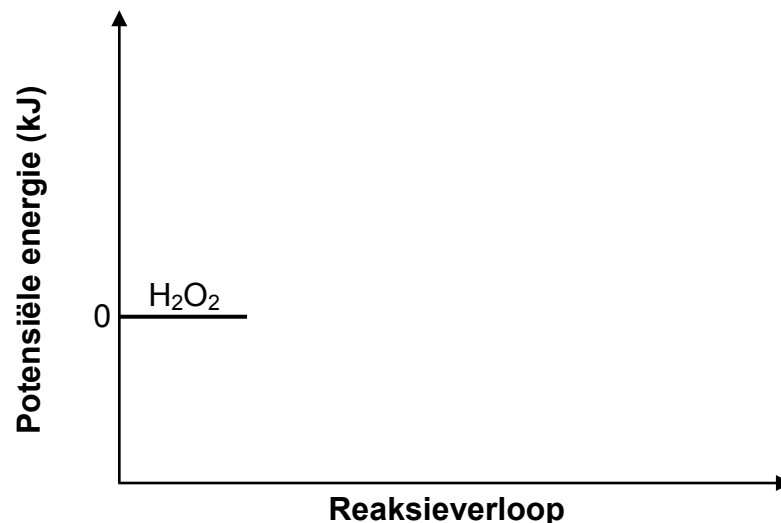

(3)

Wanneer verpoeierte mangaandioksied by die reaksiemengsel gevoeg word, neem die reaksietempo toe.

5.1.3 Op die grafiek wat vir VRAAG 5.1.2 geteken is, gebruik stippellyne om die pad van die reaksie te toon wanneer mangaandioksied bygevoeg word. (2)

5.1.4 Gebruik die botsingsteorie om te verduidelik hoe mangaandioksied die tempo van ontbinding van waterstofperoksied beïnvloed. (3)

5.2 Grafiek **A** en **B** hieronder is verkry vir die volume suurstof wat met tyd onder verskillende toestande gelewer is.

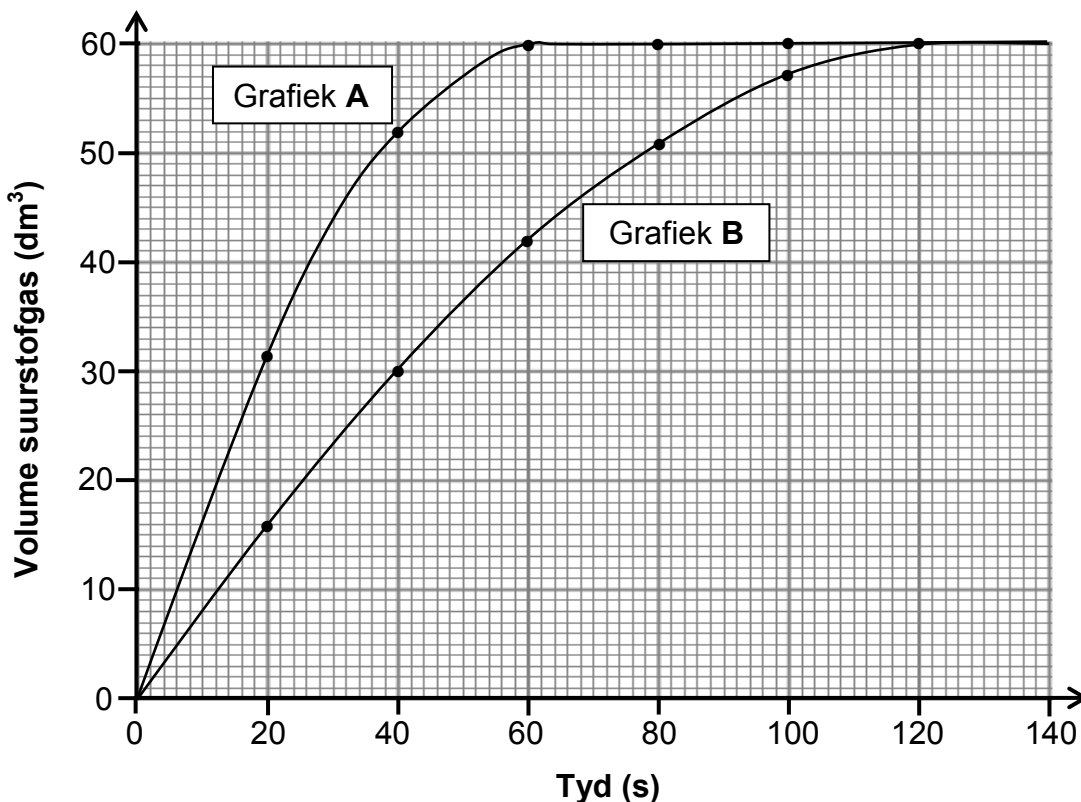

5.2.1 Bereken die gemiddelde reaksietempo (in $\text{dm}^3 \cdot \text{s}^{-1}$) tussen $t = 10 \text{ s}$ en $t = 40 \text{ s}$ vir grafiek **A**. (3)

5.2.2 Gebruik die inligting in grafiek **A** om die massa waterstofperoksied wat in die reaksie gebruik is, te bereken. Aanvaar dat al die waterstofperoksied ontbind het. Gebruik $24 \text{ dm}^3 \cdot \text{mol}^{-1}$ as die molêre volume van suurstof. (4)

5.2.3 Hoe vergelyk die massa waterstofperoksied wat gebruik is om grafiek **B** te verkry met dié wat gebruik is om grafiek **A** te verkry? Kies uit GROTER AS, KLEINER AS of GELYK AAN. (1)

- 5.3 Drie energieverreidingskurwes vir suurstofgas wat onder verskillende toestande gelever word, word in die grafiek hieronder getoon.

Die kurwe met die soliede lyn verteenwoordig 1 mol suurstofgas by 90 °C.

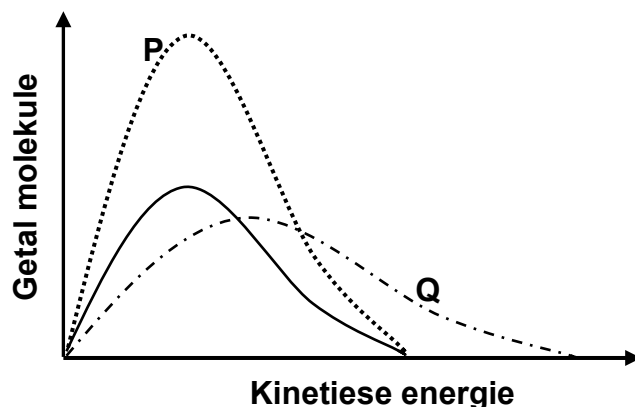

Kies die kurwe (**P** of **Q**) wat ELK van die volgende situasies die beste verteenwoordig:

- 5.3.1 1 mol suurstofgas wat by 120 °C gelever word (1)
- 5.3.2 2 mol suurstofgas wat by 90 °C gelever word (1)
- [20]**

VRAAG 6 (Begin op 'n nuwe bladsy.)

Waterstofgas, $H_2(g)$, reageer met swawelpoeier, $S(s)$, volgens die volgende gebalanseerde vergelyking:

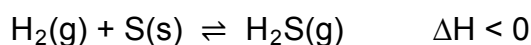

Die sisteem bereik ewewig by 90 °C.

- 6.1 Definieer die term *chemiese ewewig*. (2)
- 6.2 Hoe sal ELK van die volgende veranderinge die aantal mol $H_2S(g)$ by ewewig beïnvloed?

Kies uit VERHOOG, VERLAAG of BLY DIESELFDE.

- 6.2.1 Die byvoeging van meer swawel (1)
- 6.2.2 'n Verhoging in temperatuur
Gebruik Le Chatelier se beginsel om die antwoord te verduidelik. (4)

6.3 Die sketsgrafiek hieronder is vir die ewewigmengsel verkry.

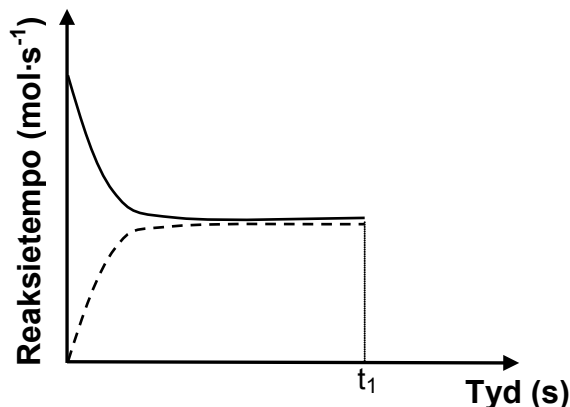

'n Katalisator word by tyd t_1 by die ewewigmengsel gevoeg.

Teken die grafiek hierbo in jou ANTWOORDEBOEK oor. Voltooi die grafiek op dieselfde asseseelsel om die effek van die katalisator op die reaksietempo's te toon.

(2)

Aanvanklik word 0,16 mol $H_2(g)$ en 'n oormaat $S(s)$ by $90\text{ }^\circ\text{C}$ in 'n 2 dm^3 -houer verseël en die sisteem word toegelaat om ewewig te bereik.

'n Presiese hoeveelheid $Pb(NO_3)_2$ -oplossing word nou in die houer bygevoeg sodat AL die $H_2S(g)$ wat in die houer by EWEWIG teenwoordig is, volgens die volgende gebalanseerde vergelyking in $PbS(s)$ omgeskakel word:

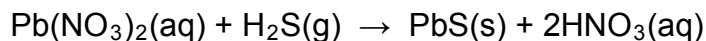

Die massa van die PbS -neerslag is 2,39 g.

6.4 Bereken die ewewigskonstante, K_c , vir die reaksie $H_2(g) + S(s) \rightleftharpoons H_2S(g)$ by $90\text{ }^\circ\text{C}$.

(9)
[18]

VRAAG 7 (Begin op 'n nuwe bladsy.)

7.1 'n Leerder los ammoniumchloried(NH_4Cl)-kristalle in water op en meet die pH van die oplossing.

7.1.1 Definieer die term *hidrolise* van 'n sout. (2)

7.1.2 Sal die pH van die oplossing GROTER AS, KLEINER AS of GELYK AAN 7 wees? Skryf 'n relevante vergelyking neer om jou antwoord te ondersteun. (3)

7.2 'n Swawelsuuroplossing word berei deur 7,35 g $\text{H}_2\text{SO}_4(\ell)$ in 500 cm^3 water op te los.

7.2.1 Bereken die aantal mol H_2SO_4 wat in hierdie oplossing teenwoordig is. (2)

Natriumhidroksied(NaOH)-korrels word by die $500 \text{ cm}^3 \text{H}_2\text{SO}_4$ -oplossing gevoeg.

Die gebalanseerde vergelyking vir die reaksie is:

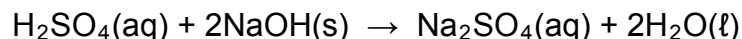

Na voltooiing van die reaksie word gevind dat die pH van die oplossing 1,3 is. Aanvaar volledige ionisasie van H_2SO_4 .

7.2.2 Bereken die massa NaOH wat by die H_2SO_4 -oplossing gevoeg is. Aanvaar dat die volume van die oplossing onveranderd bly. (9)
[16]

VRAAG 8 (Begin op 'n nuwe bladsy.)

8.1 'n Nikkel (Ni)-staaf word in 'n beker geplaas wat 'n silwernitraatoplossing, $\text{AgNO}_3(\text{aq})$, bevat en 'n reaksie vind plaas.

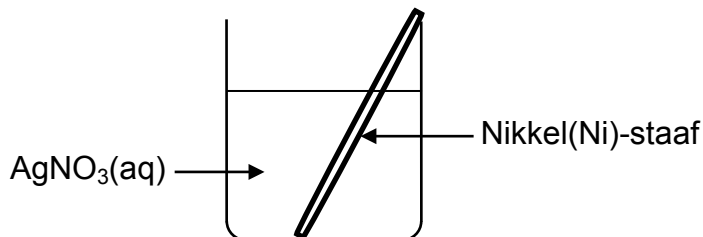

Skryf neer die:

- 8.1.1 NAAM of FORMULE van die elektroliet (1)
- 8.1.2 Oksidasie-halfreaksie wat plaasvind (2)
- 8.1.3 Gebalanseerde vergelyking vir die netto (algehele) redoksreaksie wat plaasvind (3)

8.2 'n Galvaniese sel word nou opgestel deur 'n nikkelhalfsel en 'n silwerhalfsel te gebruik.

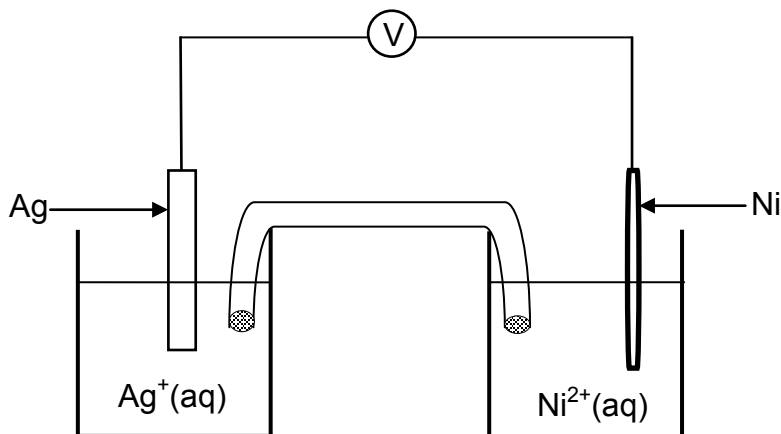

- 8.2.1 Watter elektrode (**Ni** of **Ag**) moet aan die negatiewe terminaal van die voltmeter geskakel word? Gee 'n rede vir die antwoord. (2)
- 8.2.2 Skryf die selnotasie vir die galvaniese sel hierbo neer. (3)
- 8.2.3 Bereken die aanvanklike lesing op die voltmeter indien die sel onder standaardtoestande funksioneer. (4)
- 8.2.4 Hoe sal die voltmeterlesing in VRAAG 8.2.3 beïnvloed word indien die konsentrasie van die silwer-ione verhoog word? Kies uit VERHOOG, VERLAAG of BLY DIESELFDE. (1)

[16]

VRAAG 9 (Begin op 'n nuwe bladsy.)

In die elektrochemiese sel hieronder word koolstofelektrodes gebruik tydens die elektrolise van 'n gekonsentreerde natriumchloriedoplossing.

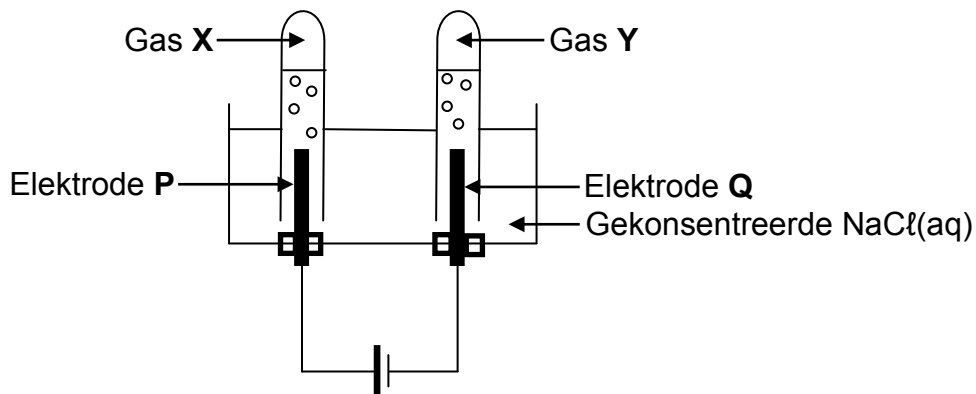

Die gebalanseerde vergelyking vir die netto (algehele) selreaksie is:



- 9.1 Is die reaksie EKSOTERMIES of ENDOTERMIES? (1)
- 9.2 Is elektrode **P** die ANODE of die KATODE? Gee 'n rede vir die antwoord. (2)
- 9.3 Skryf neer die:
- 9.3.1 NAAM of FORMULE van gas **X** (1)
- 9.3.2 NAAM of FORMULE van gas **Y** (1)
- 9.3.3 Reduksie-halfreaksie (2)
- 9.4 Is die oplossing in die sel SUUR of ALKALIES (BASIES) na voltooiing van die reaksie? Gee 'n rede vir die antwoord. (2)
- [9]**

VRAAG 10 (Begin op 'n nuwe bladsy.)

10.1 Die vloeiagram hieronder toon die prosesse wat by die industriële bereiding van kunsmis **Q** betrokke is.

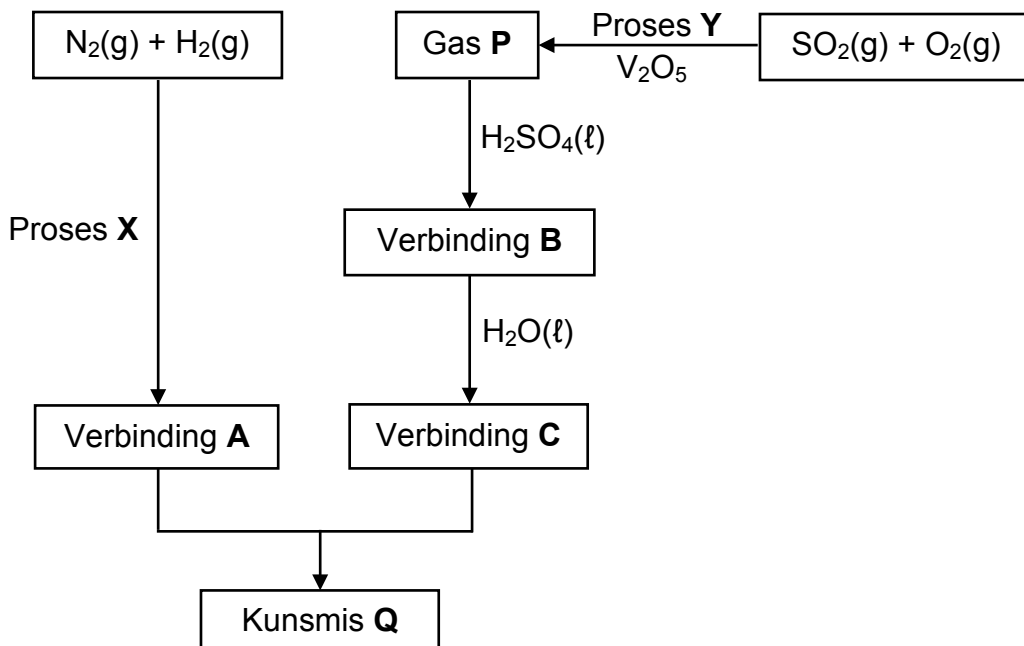

Skryf neer die:

- 10.1.1 Naam van prosesse **X** (1)
- 10.1.2 Naam van prosesse **Y** (1)
- 10.1.3 NAAM of FORMULE van gas **P** (1)
- 10.1.4 Gebalanseerde vergelyking vir die vorming van verbinding **B** (3)
- 10.1.5 Gebalanseerde vergelyking vir die vorming van kunsmis **Q** (4)

10.2 Die diagram hieronder toon 'n sak NPK-kunsmis waarvan die NPK-verhouding onbekend is. Daar is gevind dat die massa stikstof in die sak 4,11 kg en die massa fosfor 0,51 kg is.

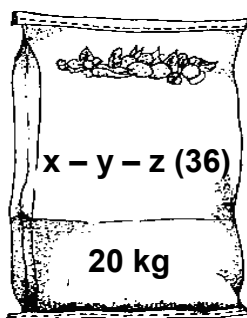

Bereken die NPK-verhouding van die kunsmis.

(4)
[14]

TOTAAL: 150

**DATA FOR PHYSICAL SCIENCES GRADE 12
PAPER 2 (CHEMISTRY)**

**GEGEWENS VIR FISIESTE WETENSKAPPE GRAAD 12
VRAESTEL 2 (CHEMIE)**

TABLE 1: PHYSICAL CONSTANTS/TABEL 1: FISIESTE KONSTANTES

NAME/NAAM	SYMBOL/SIMBOOL	VALUE/WAARDE
Standard pressure <i>Standaarddruk</i>	p^θ	$1,013 \times 10^5 \text{ Pa}$
Molar gas volume at STP <i>Molêre gasvolume by STD</i>	V_m	$22,4 \text{ dm}^3 \cdot \text{mol}^{-1}$
Standard temperature <i>Standaardtemperatuur</i>	T^θ	273 K
Charge on electron <i>Lading op elektron</i>	e	$-1,6 \times 10^{-19} \text{ C}$
Avogadro's constant <i>Avogadro-konstante</i>	N_A	$6,02 \times 10^{23} \text{ mol}^{-1}$

TABLE 2: FORMULAE/TABEL 2: FORMULES

$n = \frac{m}{M}$	$n = \frac{N}{N_A}$
$c = \frac{n}{V}$ or/of $c = \frac{m}{MV}$	$n = \frac{V}{V_m}$
$\frac{c_a v_a}{c_b v_b} = \frac{n_a}{n_b}$	$\text{pH} = -\log[\text{H}_3\text{O}^+]$
$K_w = [\text{H}_3\text{O}^+][\text{OH}^-] = 1 \times 10^{-14}$ at/by 298 K	
$E_{\text{cell}}^\theta = E_{\text{cathode}}^\theta - E_{\text{anode}}^\theta$ / $E_{\text{sel}}^\theta = E_{\text{katode}}^\theta - E_{\text{anode}}^\theta$ or/of $E_{\text{cell}}^\theta = E_{\text{reduction}}^\theta - E_{\text{oxidation}}^\theta$ / $E_{\text{sel}}^\theta = E_{\text{reduksie}}^\theta - E_{\text{oksidasie}}^\theta$ or/of $E_{\text{cell}}^\theta = E_{\text{oxidising agent}}^\theta - E_{\text{reducing agent}}^\theta$ / $E_{\text{sel}}^\theta = E_{\text{oksideermiddel}}^\theta - E_{\text{reduseermiddel}}^\theta$	

TABLE 4A: STANDARD REDUCTION POTENTIALS
TABEL 4A: STANDAARDREDUKSIEPOTENSIALE

Half-reactions/ <i>Halfreaksies</i>	E^{\ominus} (V)
$F_2(g) + 2e^- \rightleftharpoons 2F^-$	+ 2,87
$Co^{3+} + e^- \rightleftharpoons Co^{2+}$	+ 1,81
$H_2O_2 + 2H^+ + 2e^- \rightleftharpoons 2H_2O$	+1,77
$MnO_4^- + 8H^+ + 5e^- \rightleftharpoons Mn^{2+} + 4H_2O$	+ 1,51
$Cl_2(g) + 2e^- \rightleftharpoons 2Cl^-$	+ 1,36
$Cr_2O_7^{2-} + 14H^+ + 6e^- \rightleftharpoons 2Cr^{3+} + 7H_2O$	+ 1,33
$O_2(g) + 4H^+ + 4e^- \rightleftharpoons 2H_2O$	+ 1,23
$MnO_2 + 4H^+ + 2e^- \rightleftharpoons Mn^{2+} + 2H_2O$	+ 1,23
$Pt^{2+} + 2e^- \rightleftharpoons Pt$	+ 1,20
$Br_2(l) + 2e^- \rightleftharpoons 2Br^-$	+ 1,07
$NO_3^- + 4H^+ + 3e^- \rightleftharpoons NO(g) + 2H_2O$	+ 0,96
$Hg^{2+} + 2e^- \rightleftharpoons Hg(l)$	+ 0,85
$Ag^+ + e^- \rightleftharpoons Ag$	+ 0,80
$NO_3^- + 2H^+ + e^- \rightleftharpoons NO_2(g) + H_2O$	+ 0,80
$Fe^{3+} + e^- \rightleftharpoons Fe^{2+}$	+ 0,77
$O_2(g) + 2H^+ + 2e^- \rightleftharpoons H_2O_2$	+ 0,68
$I_2 + 2e^- \rightleftharpoons 2I^-$	+ 0,54
$Cu^+ + e^- \rightleftharpoons Cu$	+ 0,52
$SO_2 + 4H^+ + 4e^- \rightleftharpoons S + 2H_2O$	+ 0,45
$2H_2O + O_2 + 4e^- \rightleftharpoons 4OH^-$	+ 0,40
$Cu^{2+} + 2e^- \rightleftharpoons Cu$	+ 0,34
$SO_4^{2-} + 4H^+ + 2e^- \rightleftharpoons SO_2(g) + 2H_2O$	+ 0,17
$Cu^{2+} + e^- \rightleftharpoons Cu^+$	+ 0,16
$Sn^{4+} + 2e^- \rightleftharpoons Sn^{2+}$	+ 0,15
$S + 2H^+ + 2e^- \rightleftharpoons H_2S(g)$	+ 0,14
$2H^+ + 2e^- \rightleftharpoons H_2(g)$	0,00
$Fe^{3+} + 3e^- \rightleftharpoons Fe$	- 0,06
$Pb^{2+} + 2e^- \rightleftharpoons Pb$	- 0,13
$Sn^{2+} + 2e^- \rightleftharpoons Sn$	- 0,14
$Ni^{2+} + 2e^- \rightleftharpoons Ni$	- 0,27
$Co^{2+} + 2e^- \rightleftharpoons Co$	- 0,28
$Cd^{2+} + 2e^- \rightleftharpoons Cd$	- 0,40
$Cr^{3+} + e^- \rightleftharpoons Cr^{2+}$	- 0,41
$Fe^{2+} + 2e^- \rightleftharpoons Fe$	- 0,44
$Cr^{3+} + 3e^- \rightleftharpoons Cr$	- 0,74
$Zn^{2+} + 2e^- \rightleftharpoons Zn$	- 0,76
$2H_2O + 2e^- \rightleftharpoons H_2(g) + 2OH^-$	- 0,83
$Cr^{2+} + 2e^- \rightleftharpoons Cr$	- 0,91
$Mn^{2+} + 2e^- \rightleftharpoons Mn$	- 1,18
$Al^{3+} + 3e^- \rightleftharpoons Al$	- 1,66
$Mg^{2+} + 2e^- \rightleftharpoons Mg$	- 2,36
$Na^+ + e^- \rightleftharpoons Na$	- 2,71
$Ca^{2+} + 2e^- \rightleftharpoons Ca$	- 2,87
$Sr^{2+} + 2e^- \rightleftharpoons Sr$	- 2,89
$Ba^{2+} + 2e^- \rightleftharpoons Ba$	- 2,90
$Cs^+ + e^- \rightleftharpoons Cs$	- 2,92
$K^+ + e^- \rightleftharpoons K$	- 2,93
$Li^+ + e^- \rightleftharpoons Li$	- 3,05

Increasing oxidising ability/*Toenemende oksiderende vermoë*

Increasing reducing ability/*Toenemende reduserende vermoë*

TABLE 4B: STANDARD REDUCTION POTENTIALS
TABEL 4B: STANDAARDREDUKSIEPOTENSIALE

Half-reactions/ <i>Halfreaksies</i>	E^{\ominus} (V)
$\text{Li}^+ + e^- \rightleftharpoons \text{Li}$	-3,05
$\text{K}^+ + e^- \rightleftharpoons \text{K}$	-2,93
$\text{Cs}^+ + e^- \rightleftharpoons \text{Cs}$	-2,92
$\text{Ba}^{2+} + 2e^- \rightleftharpoons \text{Ba}$	-2,90
$\text{Sr}^{2+} + 2e^- \rightleftharpoons \text{Sr}$	-2,89
$\text{Ca}^{2+} + 2e^- \rightleftharpoons \text{Ca}$	-2,87
$\text{Na}^+ + e^- \rightleftharpoons \text{Na}$	-2,71
$\text{Mg}^{2+} + 2e^- \rightleftharpoons \text{Mg}$	-2,36
$\text{Al}^{3+} + 3e^- \rightleftharpoons \text{Al}$	-1,66
$\text{Mn}^{2+} + 2e^- \rightleftharpoons \text{Mn}$	-1,18
$\text{Cr}^{2+} + 2e^- \rightleftharpoons \text{Cr}$	-0,91
$2\text{H}_2\text{O} + 2e^- \rightleftharpoons \text{H}_2(\text{g}) + 2\text{OH}^-$	-0,83
$\text{Zn}^{2+} + 2e^- \rightleftharpoons \text{Zn}$	-0,76
$\text{Cr}^{3+} + 3e^- \rightleftharpoons \text{Cr}$	-0,74
$\text{Fe}^{2+} + 2e^- \rightleftharpoons \text{Fe}$	-0,44
$\text{Cr}^{3+} + e^- \rightleftharpoons \text{Cr}^{2+}$	-0,41
$\text{Cd}^{2+} + 2e^- \rightleftharpoons \text{Cd}$	-0,40
$\text{Co}^{2+} + 2e^- \rightleftharpoons \text{Co}$	-0,28
$\text{Ni}^{2+} + 2e^- \rightleftharpoons \text{Ni}$	-0,27
$\text{Sn}^{2+} + 2e^- \rightleftharpoons \text{Sn}$	-0,14
$\text{Pb}^{2+} + 2e^- \rightleftharpoons \text{Pb}$	-0,13
$\text{Fe}^{3+} + 3e^- \rightleftharpoons \text{Fe}$	-0,06
$2\text{H}^+ + 2e^- \rightleftharpoons \text{H}_2(\text{g})$	0,00
$\text{S} + 2\text{H}^+ + 2e^- \rightleftharpoons \text{H}_2\text{S}(\text{g})$	+0,14
$\text{Sn}^{4+} + 2e^- \rightleftharpoons \text{Sn}^{2+}$	+0,15
$\text{Cu}^{2+} + e^- \rightleftharpoons \text{Cu}^+$	+0,16
$\text{SO}_4^{2-} + 4\text{H}^+ + 2e^- \rightleftharpoons \text{SO}_2(\text{g}) + 2\text{H}_2\text{O}$	+0,17
$\text{Cu}^{2+} + 2e^- \rightleftharpoons \text{Cu}$	+0,34
$2\text{H}_2\text{O} + \text{O}_2 + 4e^- \rightleftharpoons 4\text{OH}^-$	+0,40
$\text{SO}_2 + 4\text{H}^+ + 4e^- \rightleftharpoons \text{S} + 2\text{H}_2\text{O}$	+0,45
$\text{Cu}^+ + e^- \rightleftharpoons \text{Cu}$	+0,52
$\text{I}_2 + 2e^- \rightleftharpoons 2\text{I}^-$	+0,54
$\text{O}_2(\text{g}) + 2\text{H}^+ + 2e^- \rightleftharpoons \text{H}_2\text{O}_2$	+0,68
$\text{Fe}^{3+} + e^- \rightleftharpoons \text{Fe}^{2+}$	+0,77
$\text{NO}_3^- + 2\text{H}^+ + e^- \rightleftharpoons \text{NO}_2(\text{g}) + \text{H}_2\text{O}$	+0,80
$\text{Ag}^+ + e^- \rightleftharpoons \text{Ag}$	+0,80
$\text{Hg}^{2+} + 2e^- \rightleftharpoons \text{Hg}(\ell)$	+0,85
$\text{NO}_3^- + 4\text{H}^+ + 3e^- \rightleftharpoons \text{NO}(\text{g}) + 2\text{H}_2\text{O}$	+0,96
$\text{Br}_2(\ell) + 2e^- \rightleftharpoons 2\text{Br}^-$	+1,07
$\text{Pt}^{2+} + 2e^- \rightleftharpoons \text{Pt}$	+1,20
$\text{MnO}_2 + 4\text{H}^+ + 2e^- \rightleftharpoons \text{Mn}^{2+} + 2\text{H}_2\text{O}$	+1,23
$\text{O}_2(\text{g}) + 4\text{H}^+ + 4e^- \rightleftharpoons 2\text{H}_2\text{O}$	+1,23
$\text{Cr}_2\text{O}_7^{2-} + 14\text{H}^+ + 6e^- \rightleftharpoons 2\text{Cr}^{3+} + 7\text{H}_2\text{O}$	+1,33
$\text{Cl}_2(\text{g}) + 2e^- \rightleftharpoons 2\text{Cl}^-$	+1,36
$\text{MnO}_4^- + 8\text{H}^+ + 5e^- \rightleftharpoons \text{Mn}^{2+} + 4\text{H}_2\text{O}$	+1,51
$\text{H}_2\text{O}_2 + 2\text{H}^+ + 2e^- \rightleftharpoons 2\text{H}_2\text{O}$	+1,77
$\text{Co}^{3+} + e^- \rightleftharpoons \text{Co}^{2+}$	+1,81
$\text{F}_2(\text{g}) + 2e^- \rightleftharpoons 2\text{F}^-$	+2,87

Increasing oxidising ability/*Toenemende oksiderende vermoë*

Increasing reducing ability/*Toenemende reduserende vermoë*



basic education

Department:
Basic Education
REPUBLIC OF SOUTH AFRICA

**NATIONAL
SENIOR CERTIFICATE
NASIONALE
SENIOR SERTIFIKAAT**

GRADE/GRAAD 12

**PHYSICAL SCIENCES: CHEMISTRY (P2)
FISIESE WETENSKAPPE: CHEMIE (V2)**

NOVEMBER 2016

MEMORANDUM

MARKS/PUNTE: 150

**This memorandum consists of 22 pages.
*Hierdie memorandum bestaan uit 22 bladsye.***

2.2.2

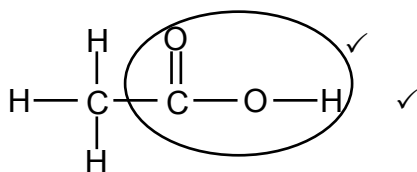
**Marking criteria/Nasienglyne:**

- Whole structure correct:
Hele struktuur korrek: $\frac{2}{2}$
- Only functional group correct./Slegs funksionele groep korrek: Max/Maks.: $\frac{1}{2}$
- Accept -OH as condensed.
Aanvaar -OH as gekondenseerd.

IF/INDIEN:

More than one functional group/Meer as een funksionele groep $\frac{0}{2}$

(2)

2.2.3

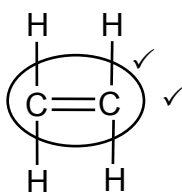
**Marking criteria/Nasienglyne:**

- Whole structure correct./Hele struktuur korrek: $\frac{2}{2}$
- Only functional group correct/Slegs funksionele groep korrek Max: $\frac{1}{2}$

IF/INDIEN:

More than one functional group/Meer as een funksionele groep $\frac{0}{2}$

(2)

2.3

2.3.1 Hydrogen (gas)/Waterstof(gas) ✓

(1)

2.3.2 Addition / Hydrogenation ✓

Addisie / Hidrogenasie / Hidrogenering

(1)

[13]**QUESTION 3/VRAAG 3**

3.1 Compounds with the same molecular formula ✓ but different structural formulae. ✓ / *Verbindings met dieselfde molekulêre formule maar verskillende struktuurformules.*

(2)

3.2 Chain/Ketting ✓

(1)

3.3 **From A to C/Van A na C:**• **Structure/Struktuur:**

Less branched / less compact / less spherical/longer chain length / larger surface area (over which intermolecular forces act). ✓

Minder vertak / minder kompak / minder sferies / langer kettinglengte / groter oppervlak (waaroor intermolekulêre kragte werk).

• **Intermolecular forces/Intermolekulêre kragte:**

Stronger / more intermolecular forces / Van der Waals forces / London forces / dispersion forces.

Sterker / meer intermolekulêre kragte / Van der Waalskragte / London-kragte / dispersiekragte. ✓

• **Energy/Energie:**

More energy needed to overcome or break intermolecular forces / Van der Waals forces. ✓

Meer energie benodig om intermolekulêre kragte / Van der Waalskragte / dispersiekragte / London-kragte te oorkom.

OR/OF

From C to A/Van C na A:

• **Structure/Struktuur:**

More branched / more compact / more spherical / smaller surface area (over which intermolecular forces act). ✓

Meer vertak / meer kompak / meer sferies / kleiner oppervlak (waaroor intermolekulêre kragte werk).

• **Intermolecular forces/Intermolekulêre kragte:**

Weaker / less intermolecular forces / Van der Waals forces / London forces / dispersion forces. ✓

Swakker/minder intermolekulêre kragte / Van der Waalskragte / Londonkragte / dispersiekragte.

Energy/Energie:

Less energy needed to overcome or break intermolecular forces / Van der Waals forces. ✓

Minder energie benodig om intermolekulêre kragte / Van der Waalskragte/ dispersiekragte / Londonkragte te oorkom.

(3)

3.4 A / 2,2-dimethylpropane / 2,2-dimetiëlpropaan ✓



Lowest boiling point. / Laagste kookpunt. ✓

(2)

3.5 $C_5H_{12} + 8O_2 \checkmark \rightarrow 5CO_2 + 6H_2O \checkmark$ Bal ✓

Notes/Aantekeninge:

- Reactants ✓ Products ✓ Balancing ✓
Reaktanse Produkte Balansering
- Ignore double arrows and phases. // *Ignoreer dubbelpyle en fases.*
- Marking rule 6.3.10/Nasienreël 6.3.10.
- If condensed structural formulae used: // *Indien gekondenseerde struktuurformules gebruik:* Max/Maks. $\frac{2}{3}$

(3)

[11]

QUESTION 4/VRAAG 4

4.1

4.1.1 High temperature / heat / high energy / high pressure ✓
Hoë temperatuur / hitte / hoë energie / hoë druk (1)

4.1.2 C_6H_{12} ✓

Accept/Aanvaar:

Condensed structural formula and structural formula.

Gekondenseerde struktuurformule en struktuurformule.

E.g./Bv: $CH_3CH_2CH_2CH_2CHCH_2$

(1)

4.1.3 Alkenes/Alkene ✓ (1)

4.2 X / C_6H_{12} / Alkene / Alkeen / Hexene / Hekseen ✓

OPTION 1/OPSIE 1

- X is an alkene / has a double bond / unsaturated. ✓
X is 'n alkeen / het 'n dubbelbinding / onversadig.
- X can undergo addition. ✓
X ondergaan addisie.
- X will react without light / heat / is more reactive. ✓
X sal sonder lig / hitte reageer / is meer reaktief.

OPTION 2/OPSIE 2

- Butane is an alkane **OR** butane is saturated. ✓
*Butaan is 'n alkaan **OF** butaan is versadig.*
- Butane can only undergo substitution. ✓
Butaan kan slegs substitusie ondergaan.
- Butane will only react in the presence of light / heat **OR** butane is less reactive. ✓
*Butaan sal slegs in die teenwoordigheid van lig / hitte reageer **OF** butaan is minder reaktief.* (4)

4.3

4.3.1 2-chloro✓ butane ✓
2-chlorobutaan (2)

4.3.2 Substitution / Hydrolysis ✓
Substitusie / Hidrolise (1)

4.3.3

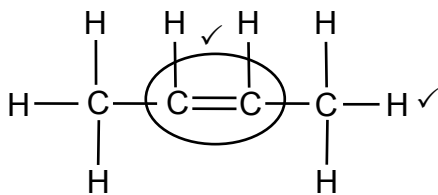

Marking criteria/Nasiemriglyne:

- Whole structure correct/Hele struktuur korrek: $\frac{2}{2}$
- Only functional group correct/Slegs funksionele groep korrek: $\frac{1}{2}$

IF/INDIEN:

More than one functional group/Meer as een funksionele groep

$\frac{0}{2}$

4.3.4 Hydration / Hidrasie / Hidratering ✓

(1)
[13]

QUESTION 5/VRAAG 5

5.1

5.1.1 The minimum energy needed for a reaction to take place. ✓✓
Die minimum energie benodig vir 'n reaksie om plaas te vind.

OR/OF

Minimum energy needed to form the activated complex./ Minimum energie nodig om die geaktiveerde kompleks te vorm.

(2)

5.1.2

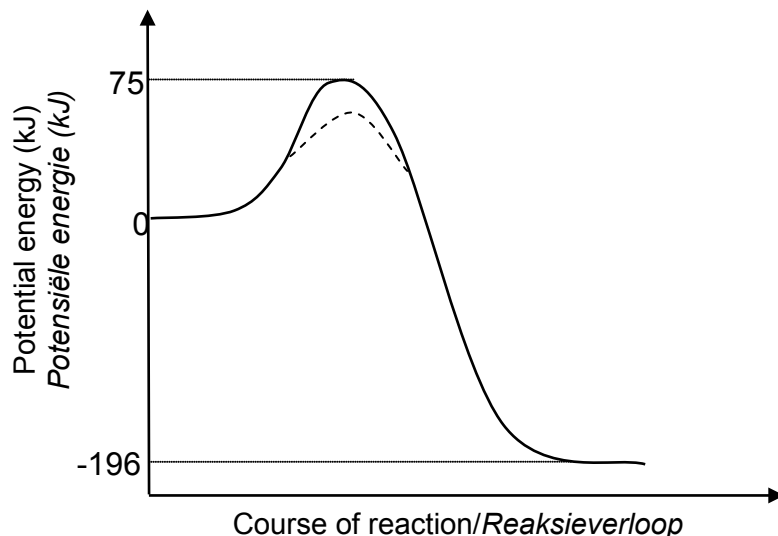

Marking criteria/Nasiemriglyne:

Shape of curve for exothermic reaction as shown.

Vorme van kurwe vir eksotermiese reaksie soos getoon.

✓

Energy of activated complex shown as 75 kJ in line with the peak.

Energie van geaktiveerde kompleks aangetoon as 75 kJ in lyn met die piek.

✓

Energy of products shown as - 196 kJ below the zero.

Energie van produkte getoon as - 196 kJ onderkant die nulpunt.

✓

IF/INDIEN: Wrong shape, e.g. straight line./Verkeerde vorm bv. reguitlyn.

$\frac{0}{3}$

(3)

5.1.3 **Marking criteria/Nasienriglyne**

- Dotted line (---) on graph in QUESTION 5.1.2 showing lower energy for activated complex. ✓
Stippellyn (---) op grafiek in VRAAG 5.1.2 wat laer energie vir geaktiveerde kompleks toon.
- Dotted curve starts at/above energy of reactants and ends at/above energy of products on the inside of the original curve. ✓
Stippellyn kurwe begin by/bokant energie van reaktanse en eindig by/bokant energie van produkte aan die binnekant van die oorspronklike kurwe.

Note/Aantekening:

Allocate marks only if curve for either exothermic or endothermic reaction drawn in QUESTION 5.1.2.

Ken punte slegs toe indien kurwe vir endotermiese of eksotermiese reaksie in VRAAG 5.1.2 geteken is.

(2)

- 5.1.4
- A catalyst provides an alternative pathway of lower activation energy. ✓
'n Katalisator voorsien 'n alternatiewe pad van laer aktiveringsenergie.

- More molecules have sufficient / enough (kinetic) energy. ✓
Meer molekule het voldoende / genoeg (kinetiese) energie.

OR/OF

More molecules have kinetic energy equal to or greater than the activation energy.

Meer molekule het kinetiese energie gelyk aan of groter as die aktiveringsenergie.

- More effective collisions per unit time / second. ✓
Meer effektiewe botsings per eenheidstyd / sekonde.

OR/OF

Rate / frequency of effective collisions increases.

Tempo / frekwensie van effektiewe botsings neem toe.

(3)

5.2

5.2.1

$$\begin{aligned} \text{Ave rate/Gem. tempo} &= \frac{\Delta V}{\Delta t} \\ &= \frac{52 - 16}{40 - 10} \checkmark \\ &= 1,2 \text{ (dm}^3 \cdot \text{s}^{-1}) \checkmark \end{aligned}$$

Accept/Aanvaar:

- Volume range/gebied:
16 to/tot 17 cm³
- Answer range/Antwoordgebied:
1,167 to 1,2 dm³·s⁻¹

(3)

5.2.2

<p>Marking criteria/Nasienriglyne:</p> <ul style="list-style-type: none"> • $V(\text{O}_2) = 60 \text{ dm}^3$ AND/EN divide volume by 24./deel volume deur 24 ✓ • Use ratio/Gebruik verhouding: $n(\text{H}_2\text{O}_2) = 2n(\text{O}_2) = 1:2$ ✓ • Use $34 \text{ g}\cdot\text{mol}^{-1}$ in $n = \frac{m}{M}$ or in ratio calculation. ✓ <p style="text-align: center;"><i>Gebruik $34 \text{ g}\cdot\text{mol}^{-1}$ in $n = \frac{m}{M}$ of in verhoudingsberekening.</i></p> <ul style="list-style-type: none"> • Final answer/Finale antwoord: 170 g ✓ 						
<p>OPTION 1/OPSIE 1</p> $n(\text{O}_2) = \frac{V}{V_M}$ $= \frac{60}{24} \checkmark$ $= 2,5 \text{ mol}$ $n(\text{H}_2\text{O}_2) = 2n(\text{O}_2)$ $= 2(2,5) \checkmark$ $= 5 \text{ mol}$ $n(\text{H}_2\text{O}_2) = \frac{m}{M}$ $\therefore 5 = \frac{m}{34} \checkmark$ $\therefore m = 170 \text{ g} \checkmark$	<p>OPTION 2/OPSIE 2</p> $24 \text{ dm}^3 : 1 \text{ mol}$ $60 \text{ dm}^3 : 2,5 \text{ mol} \checkmark$ $n(\text{H}_2\text{O}_2) = 2n(\text{O}_2)$ $= 2(2,5) \checkmark$ $= 5 \text{ mol}$ $34 \text{ g} \checkmark : 1 \text{ mol}$ $x : 5 \text{ mol}$ $x = 170 \text{ g} \checkmark$	<p>OPTION 3/OPSIE 3</p> $n(\text{O}_2) = \frac{V}{V_M}$ $= \frac{60}{24} \checkmark$ $= 2,5 \text{ mol}$ $n(\text{O}_2) = \frac{m}{M}$ $\therefore 2,5 = \frac{m}{32}$ $\therefore m = 80 \text{ g}$ \checkmark <table style="width: 100%; border: none;"> <tr> <td style="text-align: center;">$2(34) \text{ g} \checkmark \text{ H}_2\text{O}_2$</td> <td style="text-align: center;">$\dots\dots\dots 32 \text{ g O}_2$</td> </tr> <tr> <td style="text-align: center;">$x \text{ g H}_2\text{O}_2$</td> <td style="text-align: center;">$\dots\dots\dots 80 \text{ g O}_2$</td> </tr> </table> $m(\text{H}_2\text{O}_2) = 170 \text{ g} \checkmark$	$2(34) \text{ g} \checkmark \text{ H}_2\text{O}_2$	$\dots\dots\dots 32 \text{ g O}_2$	$x \text{ g H}_2\text{O}_2$	$\dots\dots\dots 80 \text{ g O}_2$
$2(34) \text{ g} \checkmark \text{ H}_2\text{O}_2$	$\dots\dots\dots 32 \text{ g O}_2$					
$x \text{ g H}_2\text{O}_2$	$\dots\dots\dots 80 \text{ g O}_2$					

(4)

5.2.3 Equal to / Gelyk aan ✓

(1)

5.3

5.3.1 Q ✓

(1)

5.3.2 P ✓

(1)

[20]

QUESTION 6/VRAAG 6

- 6.1 The stage in a chemical reaction when the rate of forward reaction equals the rate of reverse reaction. ✓✓ (2 marks or no marks)

Die stadium in 'n chemiese reaksie wanneer die tempo van die voorwaartse reaksie is gelyk aan die tempo van die terugwaartse reaksie. ✓✓
(2 punte of geen punte nie)

OR/OF

The state where the concentrations / quantities of reactants and products remain constant.

Die toestand wanneer die konsentrasies / hoeveelhede van reaktanse en produkte konstant bly. (2)

6.2

- 6.2.1 Remains the same / Bly dieselfde ✓ (1)

- 6.2.2 Decreases / Verlaag ✓



- When the temperature is increased the reaction that will oppose this increase / decrease the temperature will be favoured. ✓

Wanneer die temperatuur toeneem, sal die reaksie wat hierdie toename teenwerk / die temperatuur laat afneem bevoordeel word.

OR/OF

The forward reaction is exothermic. / Die voorwaartse reaksie is eksotermies.

- An increase in temperature favours the endothermic reaction. ✓
'n Toename in temperatuur bevoordeel die endotermiese reaksie.
- The reverse reaction is favoured. ✓
Die terugwaartse reaksie word bevoordeel. (4)

6.3

Marking criteria/Nasiennriglyne:

- Vertical parallel lines show a sudden increase in rate of both forward and reverse reactions. / Vertikale parallelle lyne wys 'n skielike toename in reaksietempo van beide voorwaartse en terugwaartse reaksies. ✓
- Horizontal parallel lines showing a constant higher rate for both forward and reverse catalysed reactions after time t_1 . / Horisontale parallelle lyne wat 'n konstante hoër tempo aantoon vir beide voorwaartse en terugwaartse gekataliseerde reaksies na t_1 . ✓

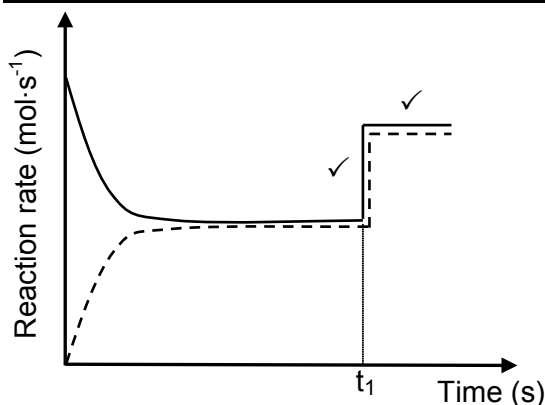

(2)

6.4 **CALCULATIONS USING NUMBER OF MOLES**
BEREKENINGE WAT AANTAL MOL GEBRUIK

Marking criteria/Nasinriglyne:

- Use/*Gebruik* $M(\text{PbS}) = 239 \text{ g} \cdot \text{mol}^{-1}$ in $n = \frac{m}{M}$ or in ratio calculation/ *of in verhoudingsberekening*. ✓
- Use ratio/*Gebruik verhouding*: $n(\text{H}_2\text{S})_{\text{equil/ewewig}} = n(\text{PbS})$ ✓
- $n(\text{H}_2\text{S})_{\text{formed/gevorm}} = n(\text{H}_2\text{S})_{\text{equilibrium/ewewig}}$ ✓
- **USING** ratio/**GEBRUIK** *verhouding*: $\text{H}_2 : \text{H}_2\text{S} = 1 : 1$ ✓
- $n(\text{H}_2)_{\text{equilibrium/ewewig}} = n(\text{H}_2)_{\text{initial/aanvanklik}} - n(\text{H}_2)_{\text{formed/gevorm}}$ ✓
- Divide equilibrium $n(\text{H}_2\text{S})$ & $n(\text{H}_2)$ by 2 dm^3 . ✓
Deel $n(\text{H}_2\text{S})$ & $n(\text{H}_2)$ deur 2 dm^3
- Correct K_c expression ✓
Korrekte K_c uitdrukking.
- Substitution of concentrations into K_c expression. ✓
Vervanging van konsentrasies in K_c -uitdrukking.
- Final answer/*Finale antwoord*: 0,07 ✓
NB/L.W.: If not rounded/*Indien nie afgerond nie*: 0,067

OPTION 1/OPSIE 1

$$n(\text{PbS}) = \frac{m}{M} = \frac{2,39}{239} = 0,01 \text{ mol}$$

$$n(\text{H}_2\text{S})_{\text{equilibrium/by ewewig}} = n(\text{PbS}) \checkmark = 0,01 \text{ mol}$$

	H ₂	H ₂ S	
Initial quantity (mol) <i>Aanvangshoeveelheid (mol)</i>	0,16	0	
Change (mol) <i>Verandering (mol)</i>	0,01	0,01 ✓	ratio ✓ <i>verhouding</i>
Quantity at equilibrium (mol)/ <i>Hoeveelheid by ewewig (mol)</i>	0,15 ✓	0,01	
Equilibrium concentration (mol·dm ⁻³) <i>Ewewigkonsentrasie (mol·dm⁻³)</i>	0,075	0,005	divide by 2 ✓ <i>deel deur 2</i>

$$K_c = \frac{[\text{H}_2\text{S}]}{[\text{H}_2]} \checkmark$$

$$= \frac{0,005}{0,075} \checkmark$$

$$= 0,067 \approx 0,07 \checkmark$$

No K_c expression, correct substitution/*Geen K_c -uitdrukking, korrekte substitusie*: Max./Maks. $\frac{8}{9}$

Wrong K_c expression /*Verkeerde K_c -uitdrukking*:
Max./Maks. $\frac{6}{9}$

IF/INDIEN: $[\text{S}] = 1$ in $K_c = \frac{[\text{H}_2\text{S}]}{[\text{H}_2][\text{S}]}$

No mark for K_c expression, but continue marking substitution and answer./*Geen punt vir K_c -uitdrukking, maar gaan voort om substitusie en antwoord na te sien.*

OPTION 2/OPSIE 2

$$n(\text{PbS}) = \frac{m}{M}$$

$$= \frac{2,39}{239} \checkmark$$

$$= 0,01 \text{ mol}$$

$$n(\text{H}_2\text{S})_{\text{reacted/gereageer}} = n(\text{PbS}) \checkmark = 0,01 \text{ mol}$$

$$= n(\text{H}_2\text{S})_{\text{equilibrium/ewewig}}$$

$$n(\text{H}_2\text{S})_{\text{formed/gevorm}} = n(\text{H}_2\text{S})_{\text{equilibrium/ewewig}} - n(\text{H}_2\text{S})_{\text{initial/aanvanklik}}$$

$$= 0,01 - 0 \checkmark$$

$$= 0,01 \text{ mol}$$

$$n(\text{H}_2)_{\text{reacted/gereageer}} = n(\text{H}_2\text{S})_{\text{formed/gevorm}} \checkmark = 0,01 \text{ mol}$$

$$n(\text{H}_2)_{\text{equilibrium/ewewig}} = n(\text{H}_2)_{\text{initial/aanvanklik}} - n(\text{H}_2)_{\text{reacted/gereageer}}$$

$$= 0,16 - 0,01 \checkmark$$

$$= 0,15 \text{ mol}$$

$$c(\text{H}_2) = \frac{n}{V}$$

$$= \frac{0,15}{2}$$

$$= 0,075 \text{ mol} \cdot \text{dm}^{-3}$$

$$c(\text{H}_2\text{S}) = \frac{n}{V}$$

$$= \frac{0,01}{2} \checkmark$$

$$= 0,005 \text{ mol} \cdot \text{dm}^{-3}$$

$$K_c = \frac{[\text{H}_2\text{S}]}{[\text{H}_2]} \checkmark$$

$$= \frac{0,005}{0,075} \checkmark$$

$$= 0,067 \approx 0,07 \checkmark$$

No K_c expression, correct substitution/Geen K_c -uitdrukking, korrekte substitusie: Max./Maks. $\frac{8}{9}$

Wrong K_c expression /Verkeerde K_c -uitdrukking: Max./Maks. $\frac{6}{9}$

IF/INDIEN: $[\text{S}] = 1$ in $K_c = \frac{[\text{H}_2\text{S}]}{[\text{H}_2][\text{S}]}$

No mark for K_c expression, but continue marking substitution and answer./Geen punt vir K_c -uitdrukking, maar gaan voort om substitusie en antwoord na te sien.

OPTION 3/OPSIE 3

	H ₂	H ₂ S	
Initial quantity (mol) <i>Aanvangshoeveelheid (mol)</i>	0,16	0	
Change (mol) <i>Verandering (mol)</i>	x	x ✓	ratio ✓ verhouding
Quantity at equilibrium (mol)/ <i>Hoeveelheid by ewewig (mol)</i>	0,16 - x ✓	x	
Equilibrium concentration (mol·dm ⁻³) <i>Ewewigkonsentrasie (mol·dm⁻³)</i>	$\frac{0,16 - x}{2}$	$\frac{x}{2}$	divide by 2 ✓ deel deur 2

$$n(\text{PbS}) = \frac{m}{M}$$

$$= \frac{2,39}{239} \checkmark$$

$$= 0,01 \text{ mol}$$

$$n(\text{H}_2\text{S})_{\text{equilibrium/by ewewig}} = n(\text{PbS}) \checkmark \therefore x = 0,01 \text{ mol}$$

$$[\text{H}_2]_{\text{equilibrium/by ewewig}} = \frac{0,16 - 0,01}{2} = 0,075 \text{ mol}\cdot\text{dm}^{-3}$$

$$[\text{H}_2\text{S}]_{\text{equilibrium/by ewewig}} = \frac{0,01}{2} = 0,005 \text{ mol}\cdot\text{dm}^{-3}$$

$$K_c = \frac{[\text{H}_2\text{S}]}{[\text{H}_2]} \checkmark$$

$$= \frac{0,005}{0,075} \checkmark$$

$$= 0,067 \approx 0,07 \checkmark$$

No K_c expression, correct substitution/Geen K_c-uitdrukking, korrekte substitusie: Max./Maks. $\frac{8}{9}$

Wrong K_c expression /Verkeerde K_c-uitdrukking: Max./Maks. $\frac{6}{9}$

IF/INDIEN: [S] = 1 in $K_c = \frac{[\text{H}_2\text{S}]}{[\text{H}_2][\text{S}]}$

No mark for K_c expression, but continue marking substitution and answer./Geen punt vir K_c-uitdrukking, maar gaan voort om substitusie en antwoord na te sien.

CALCULATIONS USING CONCENTRATION
BEREKENINGE WAT KONSENTRASIE GEBRUIK

Marking criteria/Nasinriglyne:

- Use/Gebruik $M(\text{PbS}) = 239 \text{ g}\cdot\text{mol}^{-1}$ in $n = \frac{m}{M}$ or in ratio calculation/ of in verhoudingsberekening. ✓
- Use ratio/Gebruik verhouding: $n(\text{H}_2\text{S})_{\text{equil/ewewig}} = n(\text{PbS})$ ✓
- Divide equilibrium $n(\text{H}_2\text{S})_{\text{equil}}$ & $n(\text{H}_2)_{\text{initial}}$ by 2 dm^3 . ✓
 Deel $n(\text{H}_2\text{S})_{\text{ewewig}}$ & $n(\text{H}_2)_{\text{aanvanklik}}$ deur 2 dm^3
- $[\text{H}_2\text{S}]_{\text{formed/gevorm}} = [\text{H}_2\text{S}]_{\text{equilibrium/ewewig}}$ ✓
- **USING** ratio/**GEBRUIK** verhouding: $\text{H}_2 : \text{H}_2\text{S} = 1 : 1$ ✓
- $[\text{H}_2]_{\text{equilibrium/ewewig}} = [\text{H}_2]_{\text{initial/aanvanklik}} - [\text{H}_2]_{\text{formed/gevorm}}$ ✓
- Correct K_c expression ✓
 Korrekte K_c uitdrukking.
- Substitution of concentrations into K_c expression. ✓
 Vervanging van konsentrasies in K_c -uitdrukking.
- Final answer/Finale antwoord: 0,07 ✓
Note/Let Wel: If not rounded/Indien nie afgerond nie: 0,067

OPTION 4/OPSIE 4

$$n(\text{PbS}) = \frac{m}{M} = \frac{2,39}{239} = 0,01 \text{ mol}$$

$$n(\text{H}_2\text{S})_{\text{equilibrium/by ewewig}} = n(\text{PbS}) \checkmark = 0,01 \text{ mol}$$

	H_2	H_2S
Initial concentration/Aanvangskonsentrasie ($\text{mol}\cdot\text{dm}^{-3}$)	$\frac{0,16}{2} = 0,08$	0
Change in concentration/Verandering in konsentrasie ($\text{mol}\cdot\text{dm}^{-3}$)	0,005	0,005 ✓
Equilibrium concentration/Ewewigskonsentrasie ($\text{mol}\cdot\text{dm}^{-3}$)	0,075	$\frac{0,01}{2} = 0,005$

$$K_c = \frac{[\text{H}_2\text{S}]}{[\text{H}_2]}$$

$$= \frac{0,005}{0,075}$$

$$= 0,067 \approx 0,07$$

No K_c expression, correct substitution/Geen K_c -uitdrukking, korrekte substitusie: Max./Maks. $\frac{8}{9}$

Wrong K_c expression /Verkeerde K_c -uitdrukking: Max./Maks. $\frac{6}{9}$

IF/INDIEN: $[\text{S}] = 1$ in $K_c = \frac{[\text{H}_2\text{S}]}{[\text{H}_2][\text{S}]}$

No mark for K_c expression, but continue marking substitution and answer./Geen punt vir K_c -uitdrukking, maar gaan voort om substitusie en antwoord na te sien.

OPTION 5/OPSIE 5

$$n(\text{PbS}) = \frac{m}{M}$$

$$= \frac{2,39}{239}$$

$$= 0,01 \text{ mol}$$

$$n(\text{H}_2\text{S})_{\text{equilibrium/by ewewig}} = n(\text{PbS}) \checkmark = 0,01 \text{ mol}$$

$$[\text{H}_2\text{S}]_{\text{equilibrium/by ewewig}} = \frac{n}{V}$$

$$= \frac{0,01}{2}$$

$$= 0,005 \text{ mol}\cdot\text{dm}^{-3}$$

$$[\text{H}_2]_{\text{initial/aanvanklik}} = \frac{n}{V}$$

$$= \frac{0,16}{2}$$

$$= 0,08 \text{ mol}\cdot\text{dm}^{-3}$$

$$[\text{H}_2\text{S}]_{\text{formed/gevorm}} = [\text{H}_2\text{S}]_{\text{equilibrium/by ewewig}} - [\text{H}_2\text{S}]_{\text{initial/aanvanklik}}$$

$$= 0,005 - 0 \checkmark$$

$$= 0,005 \text{ mol}\cdot\text{dm}^{-3}$$

$$[\text{H}_2]_{\text{reacted/gereageer}} = [\text{H}_2\text{S}]_{\text{formed/gevorm}} \checkmark = 0,005 \text{ mol}$$

$$[\text{H}_2]_{\text{equilibrium/ewewig}} = [\text{H}_2]_{\text{initial/aanvanklik}} - [\text{H}_2]_{\text{reacted/gereageer}}$$

$$= 0,08 - 0,005 \checkmark$$

$$= 0,075 \text{ mol}$$

$$K_c = \frac{[\text{H}_2\text{S}]}{[\text{H}_2]}$$

$$= \frac{0,005}{0,075}$$

$$= 0,067 \approx 0,07$$

No K_c expression, correct substitution/Geen K_c -uitdrukking, korrekte substitusie: Max./Maks. $\frac{8}{9}$

Wrong K_c expression /Verkeerde K_c -uitdrukking: Max./Maks. $\frac{6}{9}$

IF/INDIEN: $[\text{S}] = 1$ in $K_c = \frac{[\text{H}_2\text{S}]}{[\text{H}_2][\text{S}]}$

No mark for K_c expression, but continue marking substitution and answer./Geen punt vir K_c -uitdrukking, maar gaan voort om substitusie en antwoord na te sien.

(9)
[18]

QUESTION 7/VRAAG 7

7.1

7.1.1 Hydrolysis is the reaction (of a salt) with water. ✓✓
Hidrolise is die reaksie (van 'n sout) met water.
(2 or/of 0)

Accept/Aanvaar:

A chemical reaction in which water is a reactant.
'n Chemiese reaksie waarin water 'n reaktans is.

(2)

7.1.2 Smaller than (7)/Kleiner as (7) ✓

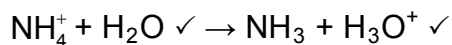

Accept/Aanvaar:

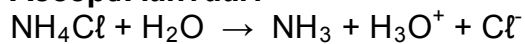

Note/Aantekening:

- Mark equation independently of first answer./Sien vergelyking onafhanklik van eerste antwoord na.
- If incorrect balancing/Indien verkeerde balansering: Max/Maks. $\frac{2}{3}$

Marking criteria for equation/Nasienriglyne vir vergelyking:

- Reactants ✓ Products ✓
Reaktanse Produkte
- Ignore double arrows and phases./Ignoreer dubbelpyle en fases.
- Marking rule 6.3.10/Nasienreël 6.3.10.

(3)

7.2

7.2.1

Marking guidelines/Nasienriglyne:

- Substitution of/Substitusie van $98 \text{ g} \cdot \text{mol}^{-1}$. ✓
- Final answer/Finale antwoord: $0,08 \text{ mol}$ ✓

Note/Let wel:

If not rounded/Indien nie afgerond nie: $(0,075 \text{ mol})$

OPTION 1/OPSIE 1

$$\begin{aligned} n &= \frac{m}{M} \\ &= \frac{7,35}{98} \\ &= 0,08 \text{ mol } \checkmark \quad (0,075 \text{ mol}) \end{aligned}$$

OPTION 2/OPSIE 2

$$\begin{aligned} 98 \text{ g } \checkmark &: 1 \text{ mol} \\ 7,35 &: 0,08 \text{ mol } \checkmark \end{aligned}$$

OPTION 3/OPSIE 3

$$\begin{aligned} c &= \frac{m}{MV} \\ &= \frac{7,35}{98 \times 0,5} \\ &= 0,15 \text{ mol} \cdot \text{dm}^{-3} \end{aligned}$$

$$\begin{aligned} n &= cV \\ &= 0,15 \times 0,5 \\ &= 0,08 \text{ mol } \checkmark \end{aligned}$$

(2)

7.2.2 **POSITIVE MARKING FROM QUESTION 7.2.1.**
POSITIEWE NASIEN VAN VRAAG 7.2.1.

OPTION 1/OPSIE 1	Marking guidelines/Nasienriglyne:
<p> $\text{pH} = -\log[\text{H}_3\text{O}^+] \checkmark$ $1,3 \checkmark = -\log[\text{H}_3\text{O}^+]$ $[\text{H}_3\text{O}^+] = 0,05 \text{ mol}\cdot\text{dm}^{-3}$ \downarrow $[\text{H}_2\text{SO}_4] = \frac{1}{2}[\text{H}_3\text{O}^+]$ $= \frac{1}{2} \times 0,05 \checkmark$ $= 0,025 \text{ mol}\cdot\text{dm}^{-3} \quad (0,03)$ \downarrow $n(\text{H}_2\text{SO}_4)_{\text{ex/oor}} = cV \checkmark$ $= 0,025 \times 0,5 \checkmark$ $= 0,0125 \text{ mol} \quad (0,02)$ \downarrow $n(\text{H}_2\text{SO}_4)_{\text{react/rea}} = 0,075 - 0,0125 \checkmark$ $= 0,0625 \text{ mol} \quad (0,06)$ \downarrow $n(\text{NaOH}) = 2n(\text{H}_2\text{SO}_4)$ $= 2 \times 0,0625 \checkmark$ $= 0,125 \text{ mol} \quad (0,12)$ </p>	<ul style="list-style-type: none"> Formula/Formule: $\text{pH} = -\log[\text{H}_3\text{O}^+] \checkmark$ Substitution of/Substitusie van 1,3 \checkmark Use $[\text{H}_2\text{SO}_4] : [\text{H}_3\text{O}^+] = 1 : 2 \checkmark$ Gebruik $[\text{H}_2\text{SO}_4] : [\text{H}_3\text{O}^+] = 1 : 2$ Formula/Formule: $c = \frac{n}{V} \checkmark$ Multiply by 0,5 dm^3 Vermenigvuldig met 0,5 $\text{dm}^3 \checkmark$ Subtract $n_{\text{initial}} - n_{\text{excess}} \checkmark$ Aftrek: $n_{\text{begin}} - n_{\text{oormaat}}$ Use $n(\text{NaOH}) : n(\text{H}_2\text{SO}_4) = 2:1 \checkmark$ Gebruik $n(\text{NaOH}) : n(\text{H}_2\text{SO}_4) = 2:1$ Substitution of $40 \text{ g}\cdot\text{mol}^{-1} \checkmark$ Vervanging van $40 \text{ g}\cdot\text{mol}^{-1}$ Final answer: $m = 5 \text{ g} \checkmark$ Finale antwoord: $m = 5 \text{ g}$ <p>Range/Gebied: 4,8 – 5,6 g</p>
OR/OF	
<p> $n(\text{NaOH}) = \frac{m}{M}$ $0,125 = \frac{m}{40} \checkmark$ $m = 5 \text{ g} \checkmark \quad (4,8 \text{ g})$ </p>	<p> $1 \text{ mol} \quad : \quad 40 \text{ g} \checkmark$ $0,125 \text{ mol} \quad : \quad 5 \text{ g} \checkmark$ </p>

<p>OPTION 2/OPSIE 2</p>	<p>Marking guidelines/Nasienriglyne:</p>
<p> $\text{pH} = -\log[\text{H}_3\text{O}^+] \checkmark$ $1,3 \checkmark = -\log[\text{H}_3\text{O}^+]$ $[\text{H}_3\text{O}^+] = 0,05 \text{ mol}\cdot\text{dm}^{-3}$ $n(\text{H}_3\text{O}^+)_{\text{ex/oor}} = cV \checkmark$ $= (0,05)(0,5) \checkmark$ $= 0,025 \text{ mol} \quad (0,03)$ $n(\text{H}_3\text{O}^+)_{\text{in/aanv}} = 2n(\text{H}_2\text{SO}_4) \checkmark$ $= 0,075 \times 2 \checkmark$ $= 0,15 \text{ mol} \quad (0,16)$ $n(\text{H}_3\text{O}^+)_{\text{react/reageer}} = 0,15 - 0,025 \checkmark$ $= 0,125 \text{ mol} \quad (0,13)$ $n(\text{NaOH}) = n(\text{H}_3\text{O}^+) \checkmark$ $= 0,125 \text{ mol} \quad (0,13)$ </p>	<ul style="list-style-type: none"> • Formula/Formule: $\text{pH} = -\log[\text{H}_3\text{O}^+] \checkmark$ • Substitution of/Substitusie van 1,3 \checkmark • Formula/Formule: $c = \frac{n}{V} \checkmark$ • Multiply by 0,5 dm^3 <i>Vermenigvuldig met 0,5 dm^3 \checkmark</i> • Use $n(\text{H}_2\text{SO}_4) : n(\text{H}_3\text{O}^+) = 1 : 2 \checkmark$ <i>Gebruik $n(\text{H}_2\text{SO}_4) : n(\text{H}_3\text{O}^+) = 1 : 2$</i> • Subtract $n_{\text{initial}} - n_{\text{excess}} \checkmark$ <i>Aftrek: $n_{\text{begin}} - n_{\text{oormaat}}$</i> • Use $n(\text{H}_3\text{O}^+) : n(\text{NaOH}) = 1 : 1 \checkmark$ <i>Gebruik $n(\text{H}_3\text{O}^+) : n(\text{NaOH}) = 1 : 1$</i> • Substitution of $40 \text{ g}\cdot\text{mol}^{-1} \checkmark$ <i>Vervanging van $40 \text{ g}\cdot\text{mol}^{-1}$</i> • Final answer: $m = 5 \text{ g} \checkmark$ <i>Finale antwoord: $m = 5 \text{ g}$</i> <p><i>Range/Gebied: 4,8 – 5,6 g</i></p>
<p style="text-align: center;">OR/OF</p> <p> $n(\text{NaOH}) = \frac{m}{M}$ $0,125 = \frac{m}{40} \checkmark$ $m = 5 \text{ g} \checkmark \quad (5,2 \text{ g})$ </p>	<p> $1 \text{ mol} : 40 \text{ g} \checkmark$ $0,125 \text{ mol} : 5 \text{ g} \checkmark$ </p>

OPTION 3/OPSIE 3	Marking guidelines/Nasienriglyne:
<p>Q7.2.1 $[H_2SO_4]_{in/aanv} = \frac{n}{V} \checkmark$ $= \frac{0,075}{0,5} \checkmark$ $= 0,15 \text{ mol} \cdot \text{dm}^{-3} \quad (0,16)$</p> <p>$[H_3O^+]_{in/aanv} = 2[H_2SO_4]$ $= 2 \times 0,15 \checkmark$ $= 0,3 \text{ mol} \cdot \text{dm}^{-3} \quad (0,32)$</p> <p>$\text{pH} = -\log[H_3O^+] \checkmark$ $1,3 \checkmark = -\log[H_3O^+]$ $[H_3O^+] = 0,05 \text{ mol} \cdot \text{dm}^{-3}$</p> <p>$[H_3O^+]_{react/rea} = 0,3 - 0,05 \checkmark$ $= 0,25 \text{ mol} \cdot \text{dm}^{-3} \quad (0,27)$</p> <p>$[H_2SO_4]_{react/rea} = \frac{1}{2}[H_3O^+]$ $= \frac{1}{2} \times 0,25$ $= 0,125 \text{ mol} \cdot \text{dm}^{-3} \quad (0,14)$</p>	<ul style="list-style-type: none"> • Formula/Formule: $c = \frac{n}{V} \checkmark$ • Divide by $0,5 \text{ dm}^3$ <i>Deel deur $0,5 \text{ dm}^3 \checkmark$</i> • Use $[H_3O^+] : [H_2SO_4] = 2:1 \checkmark$ <i>Gebruik $[H_3O^+] : [H_2SO_4] = 2:1$</i> • Formula/Formule: $\text{pH} = -\log[H_3O^+] \checkmark$ • Substitution of/Substitusie van $1,3 \checkmark$ • Subtract $[H_3O^+]_{initial} - [H_3O^+]_{excess} \checkmark$ <i>Aftrek: $[H_3O^+]_{begin} - [H_3O^+]_{oormaat}$</i> • Use $n(\text{NaOH}) : n(\text{H}_2\text{SO}_4) = 2:1 \checkmark$ <i>Gebruik $n(\text{NaOH}) : n(\text{H}_2\text{SO}_4) = 2:1$</i> <p>OR/OF</p> <p>Use $[H_2SO_4] : [NaOH] = 1 : 2 \checkmark$ <i>Gebruik $[H_2SO_4] : [NaOH] = 1 : 2$</i></p> <ul style="list-style-type: none"> • Substitution of $40 \text{ g} \cdot \text{mol}^{-1} \checkmark$ <i>Vervanging van $40 \text{ g} \cdot \text{mol}^{-1}$</i> • Final answer: $m = 5 \text{ g} \checkmark$ <i>Finale antwoord: $m = 5 \text{ g}$</i> <p><i>Range/Gebied: 4,8 – 5,6 g</i></p>
OR/OF	
<p>$n(\text{H}_2\text{SO}_4)_{react/reageer} = cV$ $= (0,125)(0,5)$ $= 0,0625 \text{ mol} \quad (0,07)$</p> <p>$n(\text{NaOH}) = 2n(\text{H}_2\text{SO}_4)$ $= 2 \times 0,0625 \checkmark$ $= 0,125 \text{ mol} \quad (0,14)$</p> <p>$n(\text{NaOH}) = \frac{m}{M}$ $0,125 = \frac{m}{40} \checkmark$ $m = 5 \text{ g} \checkmark \quad (5,6 \text{ g})$</p>	<p>$[H_2SO_4] : [NaOH]$ $1 : 2$ $0,125 : 0,25 \checkmark \quad (0,28)$</p> <p>$m = cMV$ $= 0,25 \times 40 \checkmark \times 0,5$ $= 5 \text{ g} \checkmark \quad (5,6 \text{ g})$</p>

(9)
[16]

QUESTION 8/VRAAG 8

8.1

8.1.1 AgNO_3 / Silver nitrate ✓
AgNO₃ / Silwernittraat (1)

8.1.2 $\text{Ni} \rightarrow \text{Ni}^{2+} + 2\text{e}^-$ ✓✓

Marking guidelines/Nasienriglyne:			
• $\text{Ni} \rightleftharpoons \text{Ni}^{2+} + 2\text{e}^-$	$\frac{1}{2}$	$\text{Ni}^{2+} + 2\text{e}^- \rightleftharpoons \text{Ni}$	$\frac{0}{2}$
$\text{Ni}^{2+} + 2\text{e}^- \leftarrow \text{Ni}$	$\frac{2}{2}$	$\text{Ni}^{2+} + 2\text{e}^- \rightarrow \text{Ni}$	$\frac{0}{2}$
• Ignore if charge omitted on electron. / <i>Ignoreer indien lading weggelaat op elektron.</i>			
• If charge (+) omitted on Ni^{2+} / <i>Indien lading (+) weggelaat op Ni^{2+}: Max./Maks: $\frac{1}{2}$</i>			
Example/Voorbeeld: $\text{Ni} \rightarrow \text{Ni}^{2+} + 2\text{e}^-$ ✓			

(2)

8.1.3 $\text{Ni} + 2\text{Ag}^+ \rightarrow \text{Ni}^{2+} + 2\text{Ag}$ ✓ Bal ✓

OR/OF

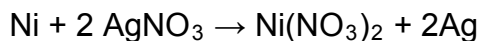

Notes/Aantekeninge:		
• Reactants ✓	Products ✓	Balancing: ✓
<i>Reaktanse</i>	<i>Produkte</i>	<i>Balansering</i>
• Ignore double arrows. / <i>Ignoreer dubbelpyle.</i>		
• Marking rule 6.3.10 / <i>Nasienreël 6.3.10.</i>		

(3)

8.2

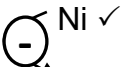
8.2.1  Ni ✓

Ni is a stronger reducing agent. / Ni has a higher reducing ability. / Ni is the anode. / Ni loses electrons. / Ni is oxidised. ✓
Ni is die sterker reduseermiddel. / Ni het sterker reduseer vermoë. / Ni is die anode. / Ni verloor elektrone. / Ni word geoksideer. (2)

8.2.2 $\text{Ni}(\text{s}) \mid \text{Ni}^{2+}(\text{aq}) \parallel \text{Ag}^+(\text{aq}) \mid \text{Ag}(\text{s})$

OR/OF

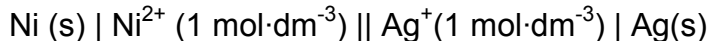

Accept/Aanvaar:



(3)

8.2.3

<p>OPTION 1/OPSIE 1</p> $E_{\text{cell}}^{\theta} = E_{\text{reduction}}^{\theta} - E_{\text{oxidation}}^{\theta} \checkmark$ $= 0,80 \checkmark - (-0,27) \checkmark$ $= 1,07 \text{ V} \checkmark$	<p>Notes/Aantekeninge</p> <ul style="list-style-type: none"> Accept any other correct formula from the data sheet./Aanvaar enige ander korrekte formule vanaf gegewensblad. Any other formula using unconventional abbreviations, e.g. $E^{\circ}_{\text{cell}} = E^{\circ}_{\text{OA}} - E^{\circ}_{\text{RA}}$ followed by correct substitutions./Enige ander formule wat onkonvensionele afkortings gebruik bv. $E^{\circ}_{\text{sel}} = E^{\circ}_{\text{OM}} - E^{\circ}_{\text{RM}}$ gevolg deur korrekte vervangings: $\frac{3}{4}$
<p>OPTION 2/OPSIE 2</p> $\text{Ag}^+ + \text{e}^- \rightarrow \text{Ag} \quad \checkmark$ $\text{Ni} \rightarrow \text{Ni}^{2+} + 2\text{e}^- \quad \checkmark$ <hr/> $\text{Ag}^+ + \text{Ni} \rightarrow \text{Ag} + \text{Ni}^{2+} \quad \checkmark$	$E^{\theta} = 0,80 \text{ V} \checkmark$ $E^{\theta} = +0,27 \text{ V} \checkmark$ $E^{\theta} = +1,07 \text{ V} \checkmark$

(4)

8.2.4 Increases / Verhoog \checkmark

(1)

[16]

QUESTION 9/VRAAG 9

9.1 Endothermic / Endotermies \checkmark

(1)

9.2 Anode \checkmark



Connected to the positive terminal of the battery. \checkmark
Geskakel aan positiewe terminaal van battery.

(2)

9.3

9.3.1 Chlorine (gas) / Cl_2 / Chloor(gas) \checkmark

(1)

9.3.2 Hydrogen (gas) / H_2 / Waterstof(gas) \checkmark

(1)

9.3.3 $2\text{H}_2\text{O}(\text{l}) + 2\text{e}^- \rightarrow \text{H}_2(\text{g}) + 2\text{OH}^-(\text{aq}) \checkmark \checkmark$

Ignore phases/Ignoreer fases

Notes/Aantekeninge	
$\text{H}_2(\text{g}) + 2\text{OH}^-(\text{aq}) \leftarrow 2\text{H}_2\text{O}(\text{l}) + 2\text{e}^- \quad (\frac{2}{2})$	$2\text{H}_2\text{O}(\text{l}) + 2\text{e}^- \rightleftharpoons \text{H}_2(\text{g}) + 2\text{OH}^-(\text{aq})$
$(\frac{1}{2})$	
$\text{H}_2(\text{g}) + 2\text{OH}^-(\text{aq}) \rightleftharpoons 2\text{H}_2\text{O}(\text{l}) + 2\text{e}^- \quad (\frac{0}{2})$	$2\text{H}_2\text{O}(\text{l}) + 2\text{e}^- \leftarrow \text{H}_2(\text{g}) + 2\text{OH}^-(\text{aq})$
$(\frac{0}{2})$	

(2)

9.4 Basic / Basies \checkmark



OR/OF Alkaline / Alkalies

OH^- (ions) / NaOH / Strong base forms. \checkmark
 OH^- (-ione) / NaOH / Sterk basis vorm.

(2)

QUESTION 10/VRAAG 10

10.1

10.1.1 Haber (process) / *Haberproses* ✓ (1)

10.1.2 Contact process / Catalytic oxidation of SO₂ ✓
Kontakproses / Katalitiese oksidasie van SO₂ (1)

10.1.3 Sulphur trioxide / SO₃ / *Swaweltrioksied* ✓ (1)

10.1.4 SO₃ + H₂SO₄ ✓ → H₂S₂O₇ ✓ Bal. ✓

Notes/Aantekeninge

- Reactants ✓ Products ✓ Balancing ✓
Reaktanse Produkte Balansering
- Ignore/*Ignoreer* ⇌ and phases/*en fases*.
- Marking rule 6.3.10/*Nasienreël 6.3.10*

(3)

10.1.5 H₂SO₄ ✓ + 2NH₃ ✓ → (NH₄)₂SO₄ ✓ Bal. ✓

Notes/Aantekeninge

- Reactants ✓✓ Products ✓ Balancing ✓
Reaktanse Produkte Balansering
- Ignore/*Ignoreer* ⇌ and phases/*en fases*.
- Marking rule 6.3.10/*Nasienreël 6.3.10*

(4)

10.2

Marking guidelines/Nasienriglyne:

- Calculate the mass of fertiliser./Bereken die massa kunsmis.
- Add %N and %P OR/OF mass N and mass P.
 Tel %N en %P OR/OF massa N en massa P bymekaar.
- Subtraction/Aftrekking: $100 - (\%N + \%P)$
 OR/OF $m(\text{fertiliser/kunsmis}) - [m(N) + m(P)]$
 OR/OF $\% \text{fertiliser/kunsmis} - [\%N + \%P]$
- Final answer/Finale antwoord: 8:1:5

OPTION 1/OPSIE 1

$$m(\text{fertiliser/kunsmis}) = \frac{36}{100} \times 20 \checkmark$$

$$= 7,2 \text{ kg}$$

$$\%N = \frac{4,11}{7,2} \times 100$$

$$= 57,08\%$$

$$\%P = \frac{0,51}{7,2} \times 100$$

$$= 7,08\%$$

$$\%K = \frac{100 - \checkmark (57,08 + 7,08) \checkmark}{100}$$

$$= 35,84\%$$

$$57,08 : 7,08 : 35,84$$

$$8 : 1 : 5 \checkmark$$

OPTION 2/OPSIE 2

$$m(\text{fertiliser/kunsmis}) = \frac{36}{100} \times 20 \checkmark$$

$$= 7,2 \text{ kg}$$

$$m(K) = \frac{7,2 - \checkmark (4,11 + 0,51) \checkmark}{100}$$

$$= 2,58 \text{ kg}$$

$$4,11 : 0,51 : 2,58$$

$$8 : 1 : 5 \checkmark$$

OPTION 3/OPSIE 3

$$\%N = \frac{4,11}{20} \times 100 = 20,55\%$$

$$\%P = \frac{0,51}{20} \times 100 = 2,55\%$$

$$\%K = \frac{36 - \checkmark (20,55 + 2,55) \checkmark}{100} = 12,9\%$$

$$20,55 : 2,55 : 12,9$$

$$8 : 1 : 5 \checkmark$$

(4)
 [14]

TOTAL/TOTAAL: 150