



basic education

Department:
Basic Education
REPUBLIC OF SOUTH AFRICA

**NASIONALE
SENIOR SERTIFIKAAT**

GRAAD 12

FISIESE WETENSKAPPE: FISIKA (V1)

NOVEMBER 2016

PUNTE: 150

TYD: 3 uur

Hierdie vraestel bestaan uit 16 bladsye en 3 gegewensblaaië.

INSTRUKSIES EN INLIGTING

1. Skryf jou sentrumnommer en eksamennommer in die toepaslike ruimtes op die ANTWOORDEBOEK.
2. Hierdie vraestel bestaan uit 10 vrae. Beantwoord AL die vrae in die ANTWOORDEBOEK.
3. Begin ELKE vraag op 'n NUWE bladsy in die ANTWOORDEBOEK.
4. Nommer die antwoorde korrek volgens die nommeringstelsel wat in hierdie vraestel gebruik is.
5. Laat EEN reël oop tussen twee subvrae, byvoorbeeld tussen VRAAG 2.1 en VRAAG 2.2.
6. Jy mag 'n nieprogrammeerbare sakrekenaar gebruik.
7. Jy mag toepaslike wiskundige instrumente gebruik.
8. Jy word aangeraai om die aangehegte GEGEWENSBLAAIE te gebruik.
9. Toon ALLE formules en substitusies in ALLE berekeninge.
10. Rond jou finale numeriese antwoorde tot 'n minimum van TWEE desimale plekke af.
11. Gee kort (bondige) motiverings, besprekings ensovoorts waar nodig.
12. Skryf netjies en leesbaar.

VRAAG 1: MEERVOUDIGEKEUSE-VRAE

Verskeie opsies word as moontlike antwoorde op die volgende vrae gegee. Skryf die vraagnommer (1.1–1.10) neer, kies die antwoord en maak 'n kruisie (X) oor die letter (A–D) van jou keuse in die ANTWOORDEBOEK.

VOORBEELD:

1.11 A B C D

1.1 Die geneigdheid van 'n voorwerp om in rus te bly of om sy uniforme beweging in 'n reguitlyn voort te sit, staan as ... bekend.

A traagheid

B versnelling

C Newton se Derde Wet

D Newton se Tweede Wet

(2)

1.2 Die massa van 'n ruimtevaarder op Aarde is M. Op 'n hoogte gelyk aan twee maal die radius van die Aarde, sal die **massa** van die ruimtevaarder ... wees.

A $\frac{1}{4}$ M

B $\frac{1}{9}$ M

C M

D 2 M

(2)

1.3 'n Voorwerp word vertikaal opwaarts van die grond af gegooi.

Watter EEN van die volgende is KORREK rakende die rigting van die versnelling van die voorwerp soos dit opwaarts en dan afwaarts beweeg? Ignoreer die effekte van lugweerstand.

| | VOORWERP WAT OPWAARTS BEWEEG | VOORWERP WAT AFWAARTS BEWEEG |
|---|---------------------------------|---------------------------------|
| A | Afwaarts | Opwaarts |
| B | Opwaarts | Afwaarts |
| C | Afwaarts | Afwaarts |
| D | Opwaarts | Opwaarts |

(2)

1.4 'n Persoon laat 'n glasbottel vanaf 'n sekere hoogte op 'n betonvloer val en die bottel breek. Die persoon laat val dan 'n tweede, identiese glasbottel vanaf dieselfde hoogte op 'n dik wolmat, maar die bottel breek nie.

Watter EEN van die volgende is KORREK vir die tweede bottel in vergelyking met die eerste bottel vir dieselfde momentumverandering?

| | GEMIDDELDE KRAG OP TWEDE BOTTEL | KONTAKTYD MET MAT |
|---|------------------------------------|-------------------|
| A | Groter | Kleiner |
| B | Kleiner | Kleiner |
| C | Groter | Groter |
| D | Kleiner | Groter |

(2)

1.5 'n Blok met massa m beweeg uit rus vanaf die bopunt van 'n wrywinglose skuinsvlak **QR**, soos hieronder getoon.

Die totale meganiese energie van die blok is E_Q by punt **Q** en E_R by punt **R**. Die blok se kinetiese energie by punt **Q** en **R** is onderskeidelik K_Q en K_R .

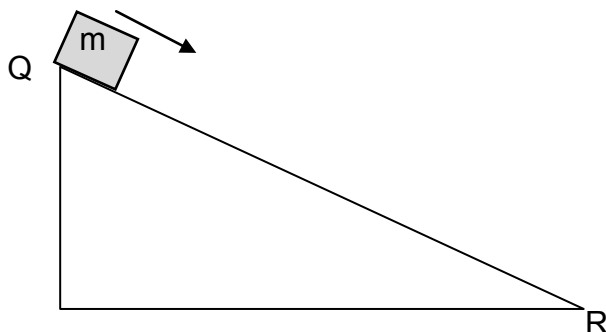

Watter EEN van die stellings oor die totale meganiese energie en die kinetiese energie van die blok by punt **Q** en **R** onderskeidelik is KORREK?

| | TOTALE MEGANIESE ENERGIE E | KINETIESE ENERGIE K |
|---|----------------------------|---------------------|
| A | $E_Q > E_R$ | $K_Q = K_R$ |
| B | $E_Q = E_R$ | $K_Q < K_R$ |
| C | $E_Q = E_R$ | $K_Q = K_R$ |
| D | $E_Q < E_R$ | $K_Q > K_R$ |

(2)

1.6 Die diagram hieronder toon die posisies van twee stilstaande luisteraars, **P** en **Q**, relatief tot 'n motor wat teen 'n konstante snelheid na luisteraar **Q** beweeg. Die toeter van die motor stel klank vry. Luisteraars **P** en **Q** en die bestuurder hoor almal die klank van die toeter.



Watter EEN van die volgende is 'n KORREKTE beskrywing van die frekwensie van die klank wat **P** en **Q** hoor *in vergelyking met dit wat die bestuurder hoor*?

| | FREKWENSIE VAN DIE KLANK WAT P HOOR | FREKWENSIE VAN DIE KLANK WAT Q HOOR |
|---|-------------------------------------|-------------------------------------|
| A | Laer | Hoër |
| B | Hoër | Hoër |
| C | Laer | Laer |
| D | Hoër | Laer |

(2)

1.7 Twee ladings, $+Q$ en $-Q$, word op 'n afstand d vanaf 'n negatiewe lading $-q$ geplaas. Die ladings, $+Q$ en $-Q$, word op lyne wat loodreg op mekaar is, gevind, soos in die diagram hieronder getoon.

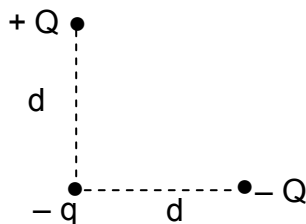

Watter EEN van die volgende pyltjies dui die rigting van die netto krag wat op lading $-q$ inwerk as gevolg van die teenwoordigheid van lading $+Q$ en $-Q$ KORREK aan?

| | |
|---|--|
| A | |
| B | |
| C | |
| D | |

(2)

- 1.8 Leerders ondersoek die verwantskap tussen stroom (I) en potensiaalverskil (V) by 'n konstante temperatuur vir drie verskillende resistors, **X**, **Y** en **Z**.

Hulle verkry die grafieke hieronder.

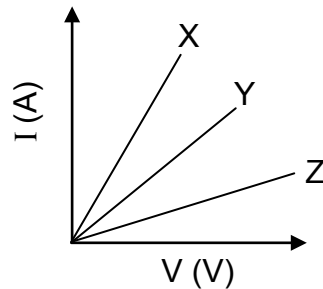

Die weerstande van **X**, **Y** en **Z** is R_X , R_Y en R_Z onderskeidelik.

Watter EEN van die volgende gevolgtrekkings oor die weerstand van die resistors is KORREK?

- A $R_Z > R_Y > R_X$
- B $R_X = R_Y = R_Z$
- C $R_X > R_Y > R_Z$
- D $R_X > R_Y$ en $R_Y < R_Z$ (2)

- 1.9 Watter EEN van die volgende veranderinge kan tot 'n toename in die emk van 'n WS-generator lei sonder om sy frekwensie te verander?

- A Verlaag die weerstand van die spoel.
- B Vergroot die oppervlakte van die spoel.
- C Verhoog die weerstand van die spoel.
- D Verlaag die rotasiespoed. (2)

- 1.10 Die golflengte van 'n monochromatiese ligbron **P** is twee keer dié van 'n monochromatiese ligbron **Q**. Die energie van 'n foton van ligbron **P** sal ... van 'n foton van bron **Q** wees.

- A 'n kwart van die energie
 - B die helfte van die energie
 - C gelyk aan die energie
 - D twee keer die energie (2)
- [20]

VRAAG 2 (Begin op 'n nuwe bladsy.)

'n Leerder bou 'n speelding wat hy kan stoot deur twee blokke met massa 1,5 kg en 3 kg onderskeidelik te gebruik. Die blokke word met 'n massalose, onrekbare toutjie verbind.

Die leerder pas dan 'n krag van 25 N teen 'n hoek van 30° op die 1,5 kg-blok toe deur middel van 'n ligte stewige staaf wat veroorsaak dat die speelding oor 'n plat, ruwe, horisontale oppervlak beweeg, soos in die diagram hieronder getoon.

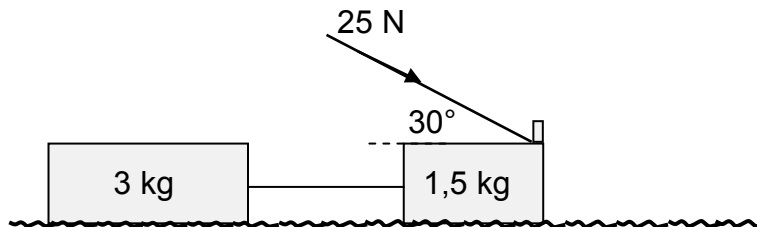

Die kinetiese wrywingkoeffisiënt (μ_k) tussen die oppervlak en elke blok is 0,15.

- 2.1 Stel Newton se Tweede Bewegingswet in woorde. (2)
- 2.2 Bereken die grootte van die kinetiese wrywingskrag wat op die 3 kg-blok inwerk. (3)
- 2.3 Teken 'n benoemde vrye kragtediagram wat AL die kragte toon wat op die 1,5 kg-blok inwerk. (5)
- 2.4 Bereken die grootte van die:
- 2.4.1 Kinetiese wrywingskrag wat op die 1,5 kg-blok inwerk (3)
- 2.4.2 Spanning in die toutjie wat die twee blokke verbind (5)
- [18]**

VRAAG 3 (Begin op 'n nuwe bladsy.)

'n Bal word vanaf die bokant van 'n 20 m hoë gebou laat val. Ignoreer die effek van lugweerstand.

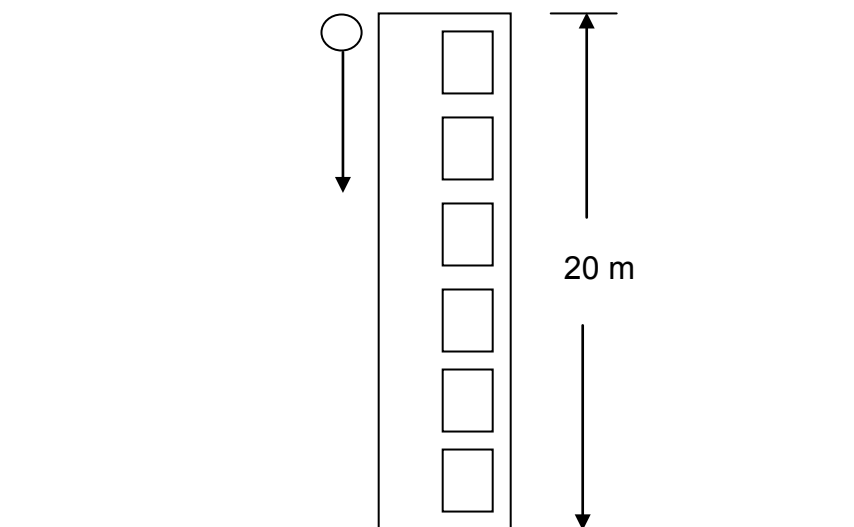

- 3.1 Definieer die term *vryval*. (2)
- 3.2 Bereken die:
- 3.2.1 Spoed waarteen die bal die grond tref (4)
- 3.2.2 Tyd wat dit die bal neem om die grond te bereik (3)
- 3.3 Skets 'n snelheid-tyd-grafiek vir die beweging van die bal (geen waardes vereis nie). (2)
- [11]**

VRAAG 4 (Begin op 'n nuwe bladsy.)

Die grafiek hieronder toon hoe die momentum van motor **A** met verloop van tyd verander *net voor* en *net nadat* dit kop teen kop met motor **B** bots.

Motor **A** het 'n massa van 1 500 kg, terwyl die massa van motor **B** 900 kg is. Motor **B** het voor die botsing teen 'n konstante snelheid van $15 \text{ m}\cdot\text{s}^{-1}$ wes beweeg. Neem oos as positief en beskou die sisteem as geïsoleerd.

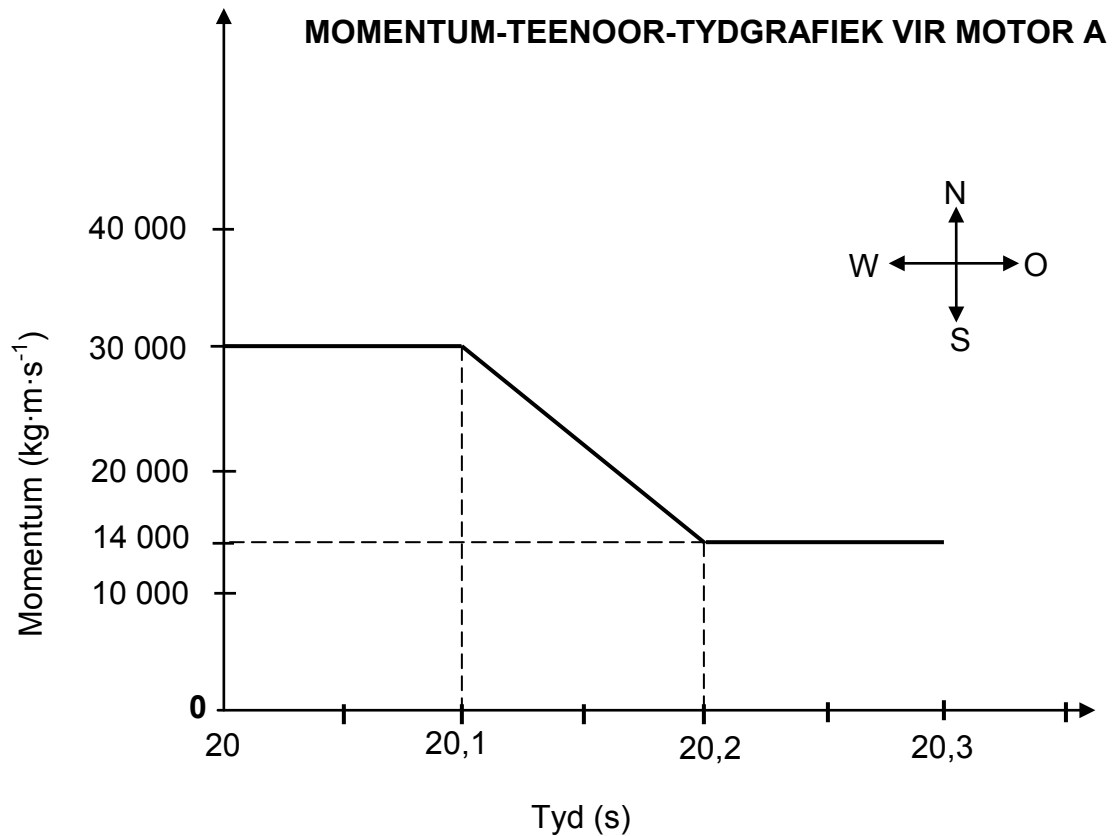

4.1 Wat verstaan jy onder die term *geïsoleerde sisteem* soos dit in fisika gebruik word? (1)

Gebruik die inligting in die grafiek om die volgende vrae te beantwoord.

- 4.2 Bereken die:
- 4.2.1 Grootte van die snelheid van motor **A** net voor die botsing (3)
 - 4.2.2 Snelheid van motor **B** net na die botsing (5)
 - 4.2.3 Grootte van die netto gemiddelde krag wat tydens die botsing op motor **A** inwerk (4)
- [13]**

VRAAG 5 (Begin op 'n nuwe bladsy.)

'n Pendulum met 'n skietlood met massa 5 kg word in rus op 'n hoogte van h meter bo die grond gehou. Wanneer dit losgelaat word, bots dit met 'n blok met massa 2 kg wat by punt **A** in rus is.

Die skietlood swaai verby **A** en kom vir 'n oomblik tot rus by 'n posisie $\frac{1}{4}h$ bo die grond.

Die diagramme hieronder is NIE volgens skaal geteken NIE.

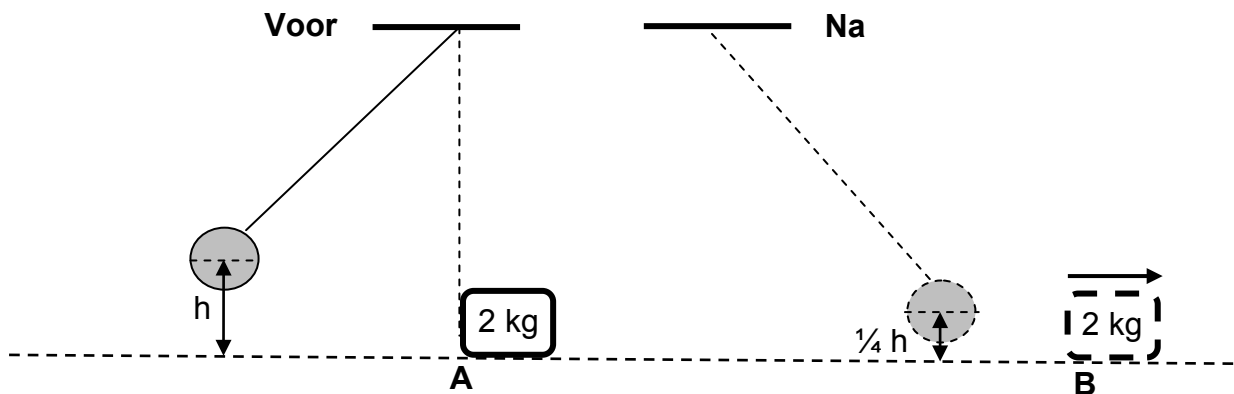

Onmiddellik na die botsing begin die 2 kg-blok teen 'n konstante spoed van $4,95 \text{ m}\cdot\text{s}^{-1}$ vanaf **A** na **B** beweeg.

Ignoreer wrywingseffekte en aanvaar dat geen verlies aan meganiese energie tydens die botsing voorkom nie.

5.1 Bereken die:

5.1.1 Kinetiese energie van die blok onmiddellik na die botsing (3)

5.1.2 Hoogte h (4)

Die blok beweeg van punt **B** met 'n snelheid van $4,95 \text{ m}\cdot\text{s}^{-1}$ teen 'n ruwe skuinsvlak op na punt **C**. Die spoed van die blok by punt **C** is $2 \text{ m}\cdot\text{s}^{-1}$. Punt **C** is 0,5 m bo die horisontaal, soos in die diagram hieronder getoon.

Tydens die beweging vanaf **B** na **C** werk 'n uniforme wrywingskrag op die blok in.

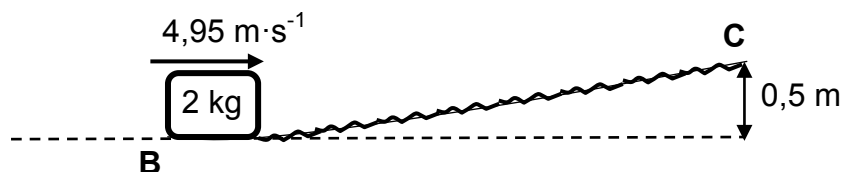

5.2 Stel die werk-energie-stelling in woorde. (2)

5.3 Gebruik energiebeginsels om die arbeid wat deur die wrywingskrag verrig word, te bereken wanneer die 2 kg-blok vanaf punt **B** na punt **C** beweeg. (4)

[13]

VRAAG 6 (Begin op 'n nuwe bladsy.)

- 6.1 'n Ambulans beweeg teen 'n konstante snelheid van $30 \text{ m}\cdot\text{s}^{-1}$ na 'n stilstaande luisteraar toe. Die sirene van die ambulans stel klankgolwe met 'n golflengte van $0,28 \text{ m}$ vry. Neem die spoed van klank in lug as $340 \text{ m}\cdot\text{s}^{-1}$.
- 6.1.1 Stel die Doppler-effek in woorde. (2)
- 6.1.2 Bereken die frekwensie van die klankgolwe wat deur die sirene voortgebring word soos dit deur die bestuurder van die ambulans gehoor word. (3)
- 6.1.3 Bereken die frekwensie van die klankgolwe wat deur die sirene voortgebring word soos dit deur die luisteraar gehoor word. (5)
- 6.1.4 Hoe sal die antwoord op VRAAG 6.1.3 verander indien die spoed van die ambulans MINDER AS $30 \text{ m}\cdot\text{s}^{-1}$ is? Skryf slegs VERHOOG, VERLAAG of BLY DIESELFDE. (1)
- 6.2 'n Waarneming van die spektrum van 'n afgeleë ster toon aan dat dit weg van die Aarde af beweeg.
- Verduidelik, ten opsigte van die frekwensies van die spektraallyne, hoe dit moontlik is om tot die gevolgtrekking te kom dat die ster weg van die Aarde af beweeg. (2)
- [13]**

VRAAG 7 (Begin op 'n nuwe bladsy.)

7.1 In 'n eksperiment om die verwantskap tussen die elektrostatische krag, F_E , en afstand, r , tussen twee **identiese**, positief gelaaiede sfer te verifieer, is die grafiek hieronder verkry.

GRAFIEK VAN F_E TEENOOR $\frac{1}{r^2}$

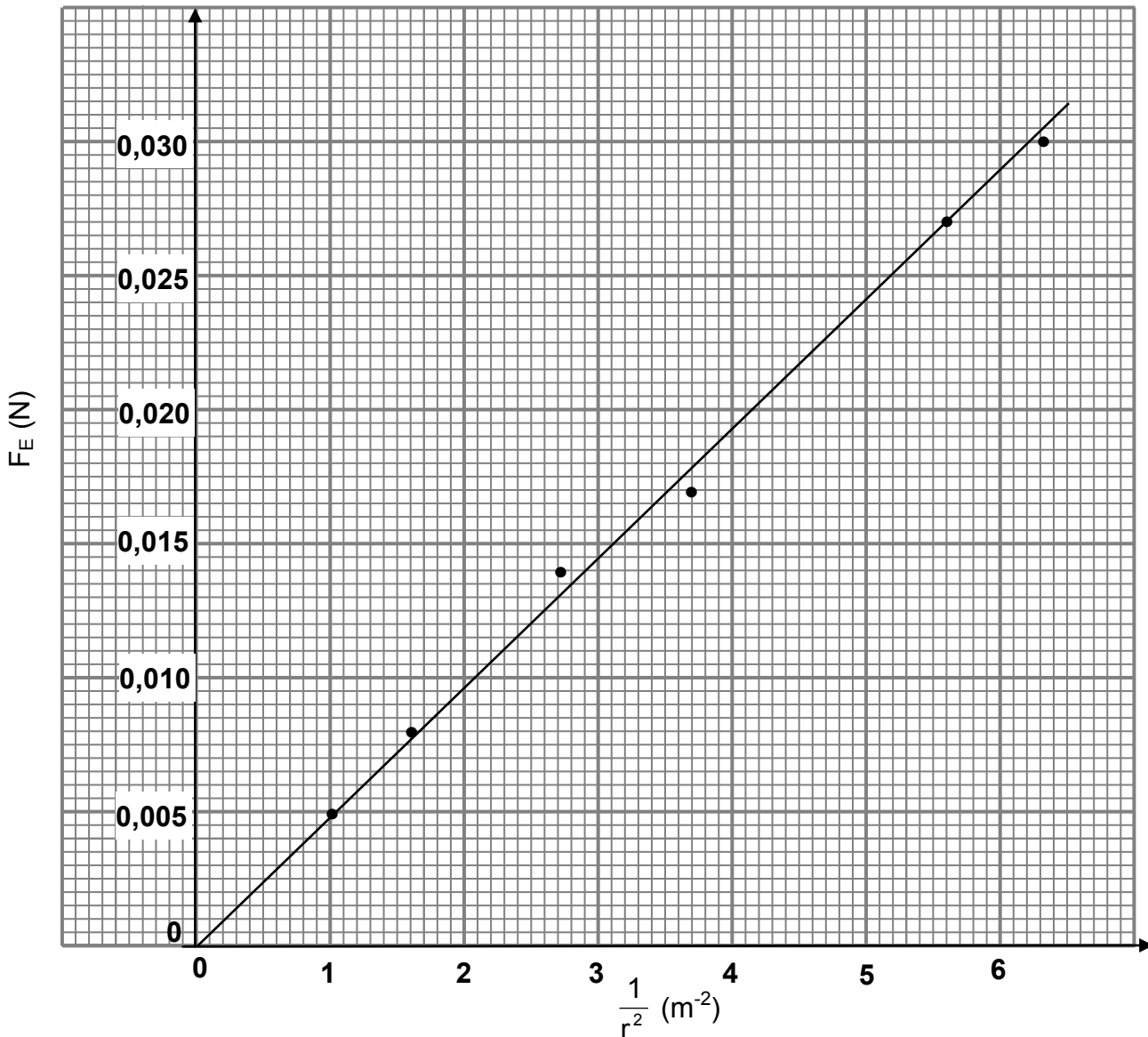

- 7.1.1 Stel Coulomb se wet in woorde. (2)
- 7.1.2 Skryf die afhanklike veranderlike van die eksperiment neer. (1)
- 7.1.3 Watter verwantskap tussen die elektrostatische krag F_E en die kwadraat van die afstand, r^2 , tussen die gelaaiede sfer kan uit die grafiek afgelei word? (1)
- 7.1.4 Gebruik die inligting in die grafiek om die lading op elke sfer te bereken. (6)

7.2 'n Gelaaide sfeer, **A**, dra 'n lading van $-0,75 \mu\text{C}$.

7.2.1 Teken 'n diagram wat die elektrieseveld-lyne rondom sfeer **A** toon. (2)

Sfeer **A** word 12 cm vanaf 'n ander gelaaide sfeer, **B**, in 'n reguitlyn in 'n vakuum geplaas, soos hieronder getoon. Sfeer **B** dra 'n lading van $+0,8 \mu\text{C}$. Punt **P** is 9 cm regs van sfeer **A** geleë.

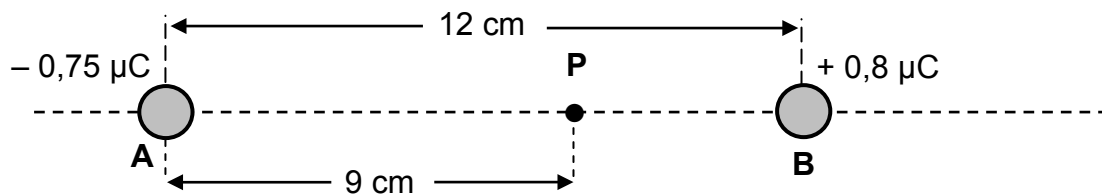

7.2.2 Bereken die grootte van die netto elektriese veld by punt **P**. (5)
[17]

VRAAG 8 (Begin op 'n nuwe bladsy.)

8.1 In die stroombaan hieronder het die battery 'n emk (ϵ) van 12 V en 'n interne weerstand van $0,2 \Omega$. Die weerstande van die verbindingsdrade is weglaatbaar.

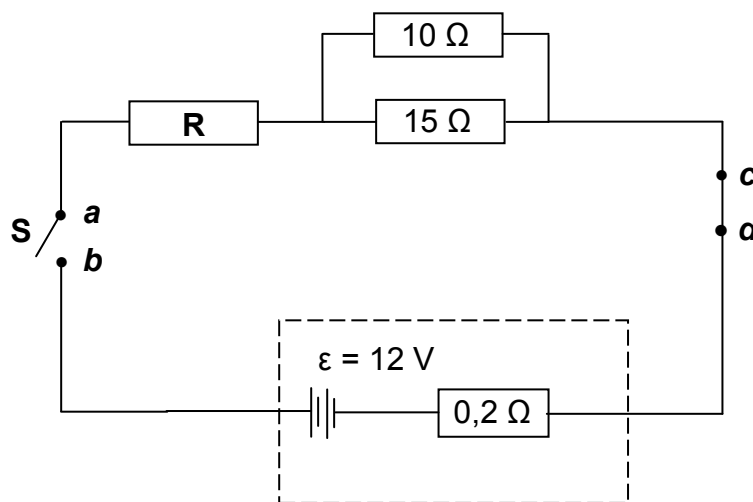

8.1.1 Definieer die term *emk van 'n battery*. (2)

8.1.2 Skakelaar **S** is oop. 'n Hoëweerstand-voltmeter is oor punt **a en b** geskakel. Wat sal die lesing op die voltmeter wees? (1)

8.1.3 Skakelaar **S** word nou gesluit. Dieselfde voltmeter word nou oor punt **c en d** geskakel. Wat sal die lesing op die voltmeter wees? (1)

Wanneer skakelaar **S** gesluit word, is die potensiaalverskil oor die terminale van die battery 11,7 V.

Bereken die:

8.1.4 Stroom in die battery (3)

8.1.5 Effektiewe weerstand van die **parallele** tak (2)

8.1.6 Weerstand van resistor **R** (4)

8.2 'n Battery met 'n emk van 12 V en 'n interne weerstand van $0,2 \Omega$ word in serie geskakel met 'n baie klein elektriese motor en 'n resistor, **T**, met onbekende weerstand, soos in die stroombaan hieronder getoon.

Die motor is **X** watt, 3 volt gemerk, en funksioneer teen optimale toestande.

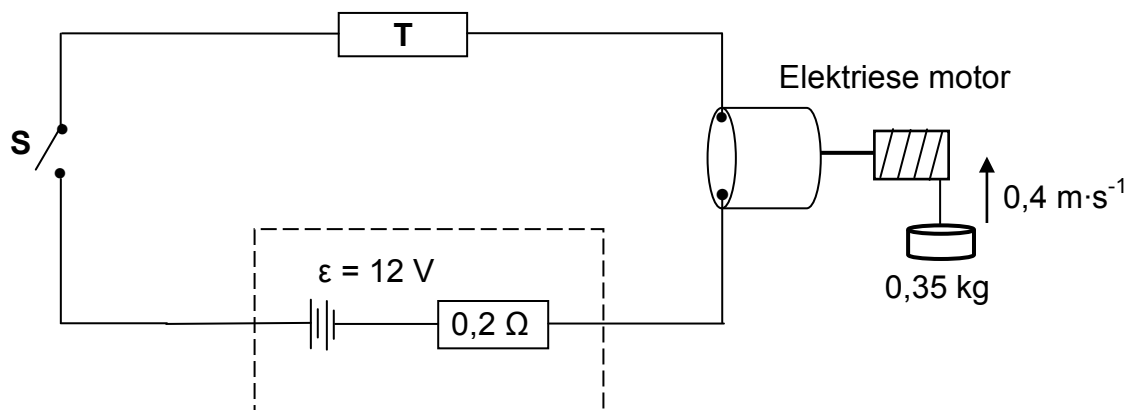

Wanneer skakelaar **S** gesluit is, hys die motor 'n massa van $0,35 \text{ kg}$ vertikaal opwaarts teen 'n konstante snelheid van $0,4 \text{ m}\cdot\text{s}^{-1}$. Aanvaar dat daar geen energie-omskakeling na hitte en klank is nie.

Bereken die waarde van:

8.2.1 **X** (3)

8.2.2 Die weerstand van resistor **T** (5)

[21]

VRAAG 9 (Begin op 'n nuwe bladsy.)

- 9.1 'n Generator word hieronder getoon. Neem aan dat die spoel in 'n vertikale posisie is.

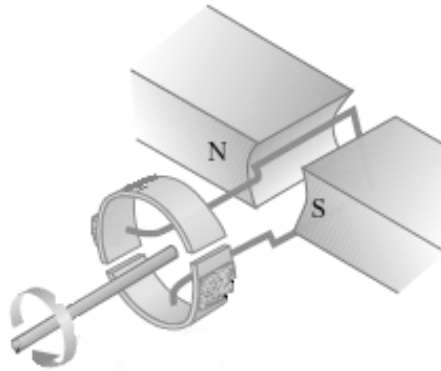

- 9.1.1 Is die generator hierbo WS of GS? Gee 'n rede vir die antwoord. (2)

- 9.1.2 Skets 'n geïnduseerde-emk-teenoortyd-grafiek vir EEN volledige rotasie van die spoel. (Die spoel begin draai vanaf die vertikale posisie.) (2)

- 9.2 'n WS-generator werk teen 'n maksimum emk van 340 V. Dit word aan 'n broodrooster en 'n ketel gekoppel, soos in die diagram hieronder getoon.

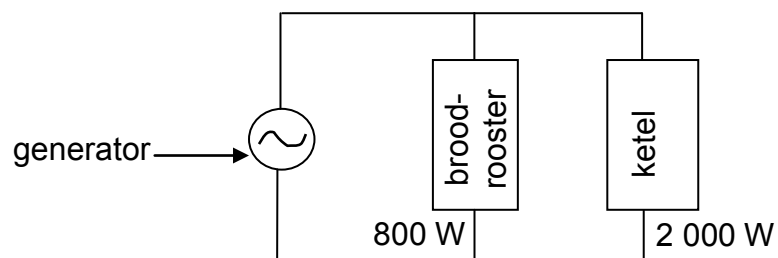

Die broodrooster is 800 W gemerk, terwyl die ketel 2 000 W gemerk is. Beide werk onder optimale toestande.

Bereken die:

- 9.2.1 wvk-stroom wat deur die broodrooster vloei (3)

- 9.2.2 Totale wvk-stroom wat deur die generator gelewer word (4)

[11]

VRAAG 10 (Begin op 'n nuwe bladsy.)

- 10.1 'n Leerder ondersoek die foto-elektriese effek vir twee verskillende metale, silwer en natrium, deur lig van verskillende frekwensies te gebruik. Die maksimum kinetiese energie van die vrygestelde foto-elektrone word teenoor die frekwensie van die lig vir elk van die metale geteken, soos getoon in die grafieke hieronder.

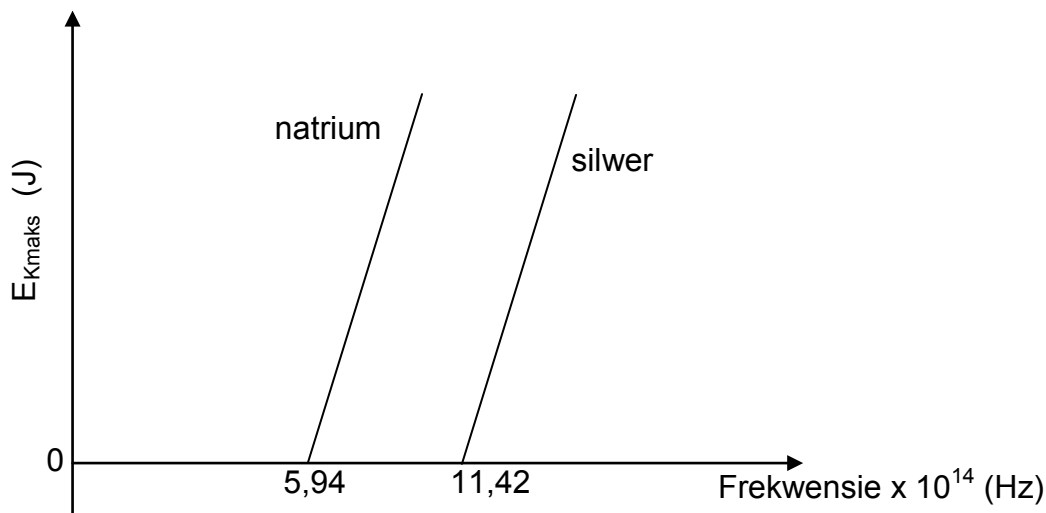

- 10.1.1 Definieer die term *drumpelfrekwensie*. (2)
- 10.1.2 Watter metaal, natrium of silwer, het die grootste arbeidsfunksie? Verduidelik die antwoord. (3)
- 10.1.3 Noem die fisiese konstante wat deur die helling van die grafieke verteenwoordig word. (1)
- 10.1.4 In watter metaal sal die vrygestelde foto-elektrone die grootste maksimum kinetiese energie hê indien lig met dieselfde frekwensie op elk van die metale geskyn word? (1)
- 10.2 In 'n ander foto-elektriese eksperiment word blou lig wat van 'n gloeilamp verkry is, op 'n metaalplaat geskyn en elektrone word vrygestel.
- Die golflengte van die blou lig is 470×10^{-9} m, en die gloeilamp is 60 mW gemerk. Die gloeilamp is slegs 5% effektief.
- 10.2.1 Bereken die getal fotone wat per sekonde op die metaalplaat sal inval as aanvaar word dat al die lig vanaf die gloeilamp op die metaalplaat inval. (5)
- 10.2.2 Skryf, **sonder enige verdere berekening**, die getal elektrone neer wat per sekonde vanaf die metaal vrygestel word. (1)

[13]**TOTAAL: 150**

**DATA FOR PHYSICAL SCIENCES GRADE 12
PAPER 1 (PHYSICS)**

**GEGEWENS VIR FISIESTE WETENSKAPPE GRAAD 12
VRAESTEL 1 (FISIKA)**

TABLE 1: PHYSICAL CONSTANTS/TABEL 1: FISIESTE KONSTANTES

| NAME/NAAM | SYMBOL/SIMBOOL | VALUE/WAARDE |
|--|----------------|---|
| Acceleration due to gravity <i>Swaartekragversnelling</i> | g | 9,8 m·s ⁻² |
| Universal gravitational constant <i>Universele gravitasiekonstant</i> | G | 6,67 x 10 ⁻¹¹ N·m ² ·kg ⁻² |
| Speed of light in a vacuum <i>Spoed van lig in 'n vakuum</i> | c | 3,0 x 10 ⁸ m·s ⁻¹ |
| Planck's constant <i>Planck se konstante</i> | h | 6,63 x 10 ⁻³⁴ J·s |
| Coulomb's constant <i>Coulomb se konstante</i> | k | 9,0 x 10 ⁹ N·m ² ·C ⁻² |
| Charge on electron <i>Lading op elektron</i> | e | 1,6 x 10 ⁻¹⁹ C |
| Electron mass <i>Elektronmassa</i> | m _e | 9,11 x 10 ⁻³¹ kg |
| Mass of the Earth <i>Massa van die Aarde</i> | M | 5,98 x 10 ²⁴ kg |
| Radius of the Earth <i>Radius van die Aarde</i> | R _E | 6,38 x 10 ⁶ m |

TABLE 2: FORMULAE/TABEL 2: FORMULES

MOTION/BEWEGING

| | |
|---|---|
| $v_f = v_i + a \Delta t$ | $\Delta x = v_i \Delta t + \frac{1}{2} a \Delta t^2$ or/of $\Delta y = v_i \Delta t + \frac{1}{2} a \Delta t^2$ |
| $v_f^2 = v_i^2 + 2a\Delta x$ or/of $v_f^2 = v_i^2 + 2a\Delta y$ | $\Delta x = \left(\frac{v_i + v_f}{2} \right) \Delta t$ or/of $\Delta y = \left(\frac{v_i + v_f}{2} \right) \Delta t$ |

FORCE/KRAG

| | |
|---|---|
| $F_{net} = ma$ | $p = mv$ |
| $f_s^{max} = \mu_s N$ | $f_k = \mu_k N$ |
| $F_{net} \Delta t = \Delta p$ $\Delta p = mv_f - mv_i$ | $w = mg$ |
| $F = G \frac{m_1 m_2}{d^2}$ or/of $F = G \frac{m_1 m_2}{r^2}$ | $g = G \frac{M}{d^2}$ or/of $g = G \frac{M}{r^2}$ |

WORK, ENERGY AND POWER/ARBEID, ENERGIE EN DRYWING

| | |
|---|--|
| $W = F \Delta x \cos \theta$ | $U = mgh$ or/of $E_p = mgh$ |
| $K = \frac{1}{2} mv^2$ or/of $E_k = \frac{1}{2} mv^2$ | $W_{net} = \Delta K$ or/of $W_{net} = \Delta E_k$ $\Delta K = K_f - K_i$ or/of $\Delta E_k = E_{kf} - E_{ki}$ |
| $W_{nc} = \Delta K + \Delta U$ or/of $W_{nc} = \Delta E_k + \Delta E_p$ | $P = \frac{W}{\Delta t}$ |
| $P_{ave} = Fv_{ave}$ / $P_{gemid} = Fv_{gemid}$ | |

WAVES, SOUND AND LIGHT/GOLWE, KLANK EN LIG

| | |
|--|--|
| $v = f \lambda$ | $T = \frac{1}{f}$ |
| $f_L = \frac{v \pm v_L}{v \pm v_s} f_s$ $f_L = \frac{v \pm v_L}{v \pm v_b} f_b$ | $E = hf$ or/of $E = h \frac{c}{\lambda}$ |
| $E = W_o + E_{k(max)}$ or/of $E = W_o + K_{max}$ where/waar | |
| $E = hf$ and/en $W_o = hf_o$ and/en $E_{k(max)} = \frac{1}{2} mv_{max}^2$ or/of $K_{max} = \frac{1}{2} mv_{max}^2$ | |

ELECTROSTATICS/ELEKTROSTATIKA

| | |
|---|----------------------|
| $F = \frac{kQ_1Q_2}{r^2}$ | $E = \frac{kQ}{r^2}$ |
| $V = \frac{W}{q}$ | $E = \frac{F}{q}$ |
| $n = \frac{Q}{e}$ or/of $n = \frac{Q}{q_e}$ | |

ELECTRIC CIRCUITS/ELEKTRIESE STROOMBANE

| | |
|--|---|
| $R = \frac{V}{I}$ | emf (ϵ) = I(R + r) emk (ϵ) = I(R + r) |
| $R_s = R_1 + R_2 + \dots$ $\frac{1}{R_p} = \frac{1}{R_1} + \frac{1}{R_2} + \dots$ | $q = I \Delta t$ |
| $W = Vq$ $W = VI \Delta t$ $W = I^2R \Delta t$ $W = \frac{V^2 \Delta t}{R}$ | $P = \frac{W}{\Delta t}$ $P = VI$ $P = I^2R$ $P = \frac{V^2}{R}$ |

ALTERNATING CURRENT/WISSELSTROOM

| | |
|--|---|
| $I_{rms} = \frac{I_{max}}{\sqrt{2}}$ / $I_{wgk} = \frac{I_{maks}}{\sqrt{2}}$ | $P_{ave} = V_{rms} I_{rms}$ / $P_{gemiddeld} = V_{wgk} I_{wgk}$ |
| $V_{rms} = \frac{V_{max}}{\sqrt{2}}$ / $V_{wgk} = \frac{V_{maks}}{\sqrt{2}}$ | $P_{ave} = I_{rms}^2 R$ / $P_{gemiddeld} = I_{wgk}^2 R$ |
| | $P_{ave} = \frac{V_{rms}^2}{R}$ / $P_{gemiddeld} = \frac{V_{wgk}^2}{R}$ |



basic education

Department:
Basic Education
REPUBLIC OF SOUTH AFRICA

**NATIONAL
SENIOR CERTIFICATE
NASIONALE
SENIOR SERTIFIKAAT**

GRADE/GRAAD 12

**PHYSICAL SCIENCES: PHYSICS (P1)
FISIESE WETENSKAPPE: FISIKA (V1)**

NOVEMBER 2016

MEMORANDUM

MARKS/PUNTE: 150

**This memorandum consists of 19 pages.
*Hierdie memorandum bestaan uit 19 bladsye.***

QUESTION 1/VRAAG 1

- 1.1 A ✓✓ (2)
 - 1.2 C ✓✓ (2)
 - 1.3 C ✓✓ (2)
 - 1.4 D ✓✓ (2)
 - 1.5 B ✓✓ (2)
 - 1.6 A ✓✓ (2)
 - 1.7 C ✓✓ (2)
 - 1.8 A ✓✓ (2)
 - 1.9 B ✓✓ (2)
 - 1.10 B ✓✓ (2)
- [20]**

QUESTION 2/VRAAG 2

2.1 When a resultant/net force acts on an object, the object will accelerate in the (direction of the net/resultant force). The acceleration is directly proportional to the net force ✓ and inversely proportional to the mass ✓ of the object.
Wanneer 'n netto krag op 'n voorwerp inwerk, versnel die voorwerp in die rigting van die netto krag teen 'n versnelling direk eweredig aan die krag en omgekeerd eweredig aan die massa van die voorwerp.

OR/OF

The resultant/net force acting on the object is equal (is directly proportional to) to the rate of change of momentum of an object (in the direction of the force). ✓✓

Die resulterende/netto krag wat op 'n voorwerp inwerk, is gelyk aan (is direk eweredig aan) die tempo van verandering van momentum van die voorwerp (in die rigting van die netto krag).

2.2

| | |
|---|-----|
| $f_k = \mu_k N \checkmark = \mu_k mg$ $= (0,15)(3)(9,8) \checkmark$ $= 4,41 \text{ N} \checkmark$ | (3) |
|---|-----|

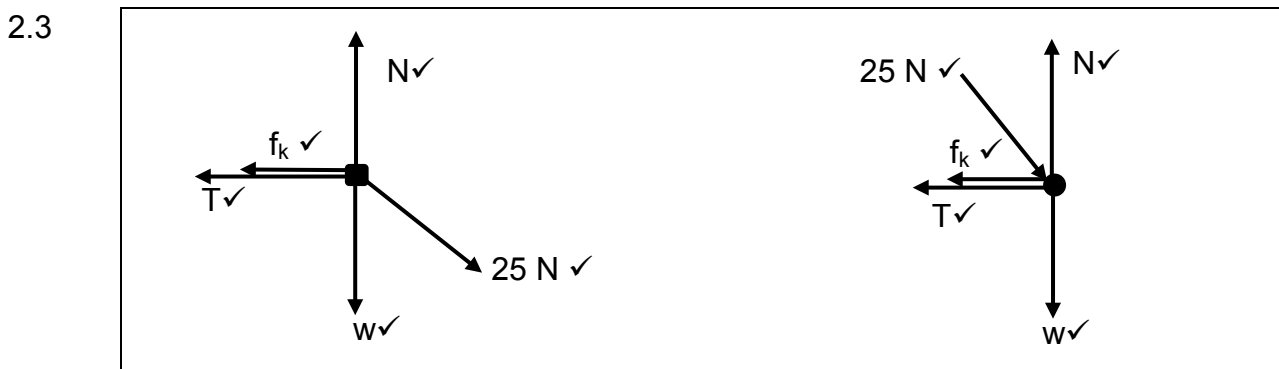

| Accepted Labels/Aanvaarde benoemings | |
|---|---|
| W | F_g/F_w /force of Earth on block/weight/14,7 N/mg/gravitational force F_g/F_w /krag van Aarde op blok/gewig/14,7 N/mg/gravitasiekrag |
| N | F_N/F_{normal} /normal force $F_N/F_{normaal}$ /normalekrag |
| T | Tension/ F_T <i>Spanning</i> / F_T |
| f_k | $f_{kinetic}$ friction/ <i>kinetiesewrywing</i> / $f_{f/w}/f//F_{f/w}$ kinetic friction/ <i>kinetiesewrywing</i> |
| 25 N | $F_{applied}/F_A/F$ $F_{toegepas}/F_A/F$ |

| | | | |
|-------|--|--|-----|
| 2.4.1 | <p>OPTION 1/OPSIE 1</p> $f_k = \mu_k N = \mu_k(25\sin 30^\circ + mg)$ $= 0,15[(25\sin 30^\circ) + (1,5)(9,8)]$ $= 4,08 \text{ N}$ | <p>OPTION 2/OPSIE 2</p> $f_k = \mu_k N = \mu_k(25\cos 60^\circ + mg)$ $= 0,15[(25\cos 60^\circ) + (1,5)(9,8)]$ $= 4,08 \text{ N}$ | (3) |
|-------|--|--|-----|

| | |
|-------|--|
| 2.4.2 | <p>POSITIVE MARKING FROM QUESTION 2.2 AND QUESTION 2.4.1 POSITIEWE NASIEN VANAF VRAAG 2.2 EN VRAAG 2.4.1</p> <p>OPTION 1/OPSIE 1</p> <p>For the 1,5 kg block/<i>Vir die 1,5 kg blok</i></p> $F_{net} = ma$ $F_x + (-T) + (-f_k) = ma$ $25 \cos 30^\circ - T - f_k = 1,5a$ $(25 \cos 30^\circ - T) - 4,08 = 1,5a$ $17,571 - T = 1,5a \dots\dots\dots(1)$ <p>For the 3 kg block <i>Vir die 3 kg blok</i></p> $T - f_k = 3a$ $T - 4,41 = 3a \dots\dots\dots(2)$ $13,161 = 4,5 a$ $a = 2,925 \text{ m}\cdot\text{s}^{-2}$ $T = 13,19 \text{ N}$ <p style="text-align: right;">(13,17 N – 13,19 N)</p> <p style="text-align: right;">✓ either one enigeen</p> |
|-------|--|

| | | | |
|---|----------------------------------|--|----------------------------------|
| <p>OPTION 2/OPSIE 2 For the 1,5 kg block/Vir die 1,5 kg blok $F_{net} = ma$ $F_x + (-T) + (-f_k) = ma$ ✓ $25 \cos 30^\circ - T - f_k = 1,5a$ $(25 \cos 30^\circ - T) - 4,08 \checkmark = 1,5a$ $17,571 - T = 1,5a \dots\dots\dots(1)$</p> <p>For the 3 kg block Vir die 3 kg blok $T - f_k = 3a$ $T - 4,41 \checkmark = 3a \dots\dots\dots(2)$</p> <p>$35,142 - 2T = T - 4,41$ $T = 13,18 \text{ N} \checkmark$</p> | <p>✓ either one enigeeen</p> | <p>OPTION 3/OPSIE 3 For the 1,5 kg block/Vir die 1,5 kg blok $F_{net} = ma$ $F_x + (-T) + (-f_k) = ma$ ✓ $25 \cos 30^\circ - T - f_k = 1,5a$ $(25 \cos 30^\circ - T) - 4,08 \checkmark = 1,5a$ $17,571 - T = 1,5a \dots\dots\dots(1)$ $a = \frac{17,571 - T}{1,5}$</p> <p>For the 3 kg block Vir die 3 kg blok $T - f_k = 3a$ $T - 4,41 \checkmark = 3a \dots\dots\dots(2)$ $a = \frac{T - 4,41}{3}$ $\frac{17,571 - T}{1,5} = \frac{T - 4,41}{3}$ $T = 13,18 \text{ N} \checkmark$</p> | <p>✓ either one enigeeen</p> |
|---|----------------------------------|--|----------------------------------|

(5)
[18]

QUESTION 3/VRAAG 3

- 3.1 The motion of an object under the influence of gravity/weight/gravitational force only / Motion in which the only force acting is the gravitational force. ✓✓
 Die beweging van 'n voorwerp slegs onder die invloed van swaartekrag/gewig gravitasiekrag.
 Beweging waarin die enigste krag wat op die liggaam inwerk, die gravitasiekrag is.

(2)

| | | | |
|--|----------------------------------|--|----------------------------------|
| <p>3.2.1 OPTION 1/OPSIE 1 Upwards positive/Opwaarts positief: $v_f^2 = v_i^2 + 2a\Delta y \checkmark$ $= 0^2 + (2)(-9,8) \checkmark (-20) \checkmark$ $v_f = 19,80 \text{ m}\cdot\text{s}^{-1} \checkmark$</p> <p>Downwards positive Afwaarts positief $v_f^2 = v_i^2 + 2a\Delta y \checkmark$ $= 0^2 + (2)(9,8) \checkmark (20) \checkmark$ $v_f = 19,80 \text{ m}\cdot\text{s}^{-1} \checkmark$</p> | <p>✓ either one enigeeen</p> | <p>OPTION 2/OPSIE 2 Upwards positive/Opwaarts positief: $\Delta y = v_i\Delta t + \frac{1}{2} a\Delta t^2$ $-20 = 0 + \frac{1}{2} (-9,8) \Delta t^2 \checkmark$ $\Delta t = 2,02 \text{ s}$ $v_f = v_i + a\Delta t$ $= 0 + (-9,8)(2,02) \checkmark$ $= -19,80 \text{ m}\cdot\text{s}^{-1}$ $= 19,80 \text{ m}\cdot\text{s}^{-1} \checkmark$</p> <p>Downwards positive Afwaarts positief $\Delta y = v_i\Delta t + \frac{1}{2} a\Delta t^2$ $20 = 0 + \frac{1}{2} (9,8) \Delta t^2 \checkmark$ $\Delta t = 2,02 \text{ s}$ $v_f = v_i + a\Delta t$ $= 0 + (9,8)(2,02) \checkmark$ $= 19,80 \text{ m}\cdot\text{s}^{-1} \checkmark$</p> | <p>✓ either one enigeeen</p> |
|--|----------------------------------|--|----------------------------------|

| | |
|--|--|
| <p>OPTION 3/OPSIE 3</p> $(E_{\text{mech}})_{\text{Top/Bo}} = (E_{\text{mech}})_{\text{Ground/Grond}}$ $(E_P + E_K)_{\text{Top}} = (E_P + E_K)_{\text{Bottom/Onder}}$ $(mgh + \frac{1}{2} mv^2)_{\text{Top/Bo}} = (mgh + \frac{1}{2} mv^2)_{\text{Bottom/Onder}}$ $(9,8)(20) + 0 \checkmark = (0 + \frac{1}{2} v_f^2) \checkmark$ $v_f = 19,80 \text{ m}\cdot\text{s}^{-1} \checkmark$ | <div style="border: 1px solid black; padding: 5px; width: fit-content; margin: auto;"> <p>✓ 1 mark for any 1 punt vir enige</p> </div> |
| <p>OPTION 4/OPSIE 4</p> $W_{\text{nc}} = \Delta E_p + \Delta E_k \checkmark$ $0 = mg\Delta h + \frac{1}{2} m\Delta v^2$ $0 \checkmark = m(9,8)(0 - 20) + \frac{1}{2} m(v_f^2 - 0) \checkmark$ $v_f = 19,80 \text{ m}\cdot\text{s}^{-1} \checkmark$ | |
| <p>OPTION 5/OPSIE 5</p> $W_{\text{net}} = \Delta E_k \checkmark$ $mg\Delta x \cos 0^\circ = \frac{1}{2} m(v_f^2 - 0)$ $\frac{m(9,8)(20)(1) \checkmark}{v_f} = \frac{1}{2} mv_f^2 \checkmark$ $v_f = 19,80 \text{ m}\cdot\text{s}^{-1} \checkmark$ | |

(4)

3.2.2

POSITIVE MARKING FROM QUESTION 3.2.1/POSITIEWE NASIEN VANAF VRAAG 3.2.1

OPTION 1/OPSIE 1
Downwards positive/Afwaarts positief

$$v_f = v_i + a\Delta t \checkmark$$

$$19,80 = 0 + (9,8)\Delta t \checkmark$$

$$\Delta t = 2,02 \text{ s} \checkmark$$

Upwards positive/Opwaarts positief

$$v_f = v_i + a\Delta t \checkmark$$

$$-19,80 = 0 + (-9,8)\Delta t \checkmark$$

$$\Delta t = 2,02 \text{ s} \checkmark$$

OPTION 2/OPSIE 2
Upwards positive/Opwaarts positief:

$$\Delta y = v_i\Delta t + \frac{1}{2} a\Delta t^2 \checkmark$$

$$-20 = 0 + \frac{1}{2} (-9,8) \Delta t^2 \checkmark$$

$$\Delta t = 2,02 \text{ s} \checkmark$$

Downwards Positive/Afwaarts positief

$$\Delta y = v_i\Delta t + \frac{1}{2} a\Delta t^2 \checkmark$$

$$20 = 0 + \frac{1}{2} (9,8) \Delta t^2 \checkmark$$

$$\Delta t = 2,02 \text{ s} \checkmark$$

OPTION 3/OPSIE 3
Downwards positive/Afwaarts positief:

$$\Delta y = \left(\frac{v_i + v_f}{2} \right) \Delta t \checkmark$$

$$20 = \left(\frac{0 + 19,80}{2} \right) (\Delta t) \checkmark$$

$$\Delta t = 2,02 \text{ s} \checkmark$$

Upwards positive/Opwaarts positief:

$$\Delta y = \left(\frac{v_i + v_f}{2} \right) \Delta t \checkmark$$

$$-20 = \left(\frac{0 - 19,80}{2} \right) (\Delta t) \checkmark$$

$$\Delta t = 2,02 \text{ s} \checkmark$$

(3)

3.3 **Downward positive/Afwaarts positief**

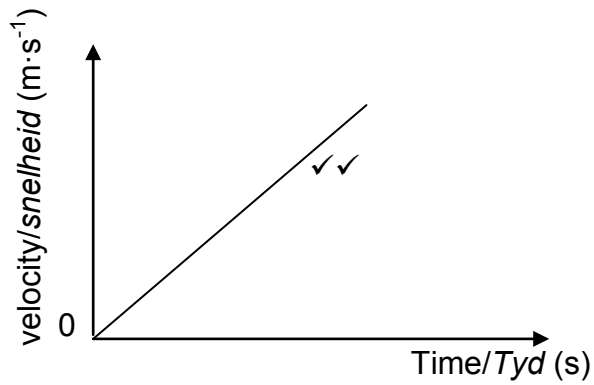

Upward positive/Opwaarts positief

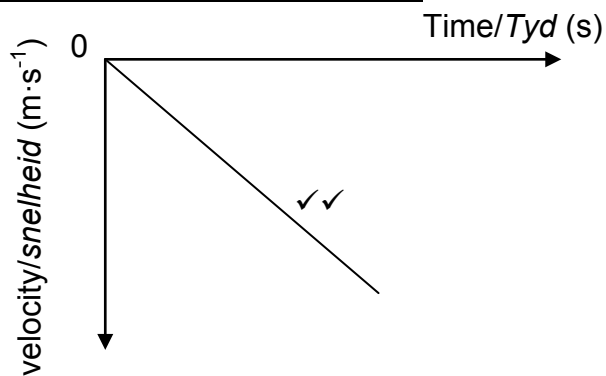

Notes/Aantekeninge

| | |
|----|--|
| ✓✓ | Straight line through the origin. <i>Reguitlyn deur die oorsprong</i> |
|----|--|

(2)
[11]

QUESTION 4/VRAAG 4

- 4.1 A system on which the resultant/net external force is zero/*n Sisteem waarop die resulterende krag/netto eksternekrag nul is* ✓
A system which excludes external forces /*n Sisteem wat eksterne kragte uitlaat.* (1)

4.2.1

| | |
|--|-----|
| <p><u>OPTION 1/OPSIE 1</u> $p = mv$ ✓ $30\,000 = (1\,500)v$ ✓ $v = 20\text{ m}\cdot\text{s}^{-1}$ ✓</p> | (3) |
| <p><u>OPTION 2/OPSIE 2</u> $\Delta p = mv_f - mv_i$ ✓ $0 = (1\,500)v_f - 30\,000$ ✓ $v = 20\text{ m}\cdot\text{s}^{-1}$ ✓</p> | |

4.2.2 **POSITIVE MARKING FROM QUESTION 4.2.1/POSITIEWE NASIEN VANAF VRAAG 4.2.1**

| | |
|---|-----|
| <p><u>OPTION 1/OPSIE 1</u> $\sum p_i = \sum p_f$ $m_1 v_{1i} + m_2 v_{2i} = m_1 v_{1f} + m_2 v_{2f}$ } ✓ 1 mark for any/1 punt vir enige $30\,000 + (900)(-15)$ ✓ = $14\,000 + 900v_B$ ✓ $\therefore v_B = 2,78\text{ m}\cdot\text{s}^{-1}$ ✓ east/oos ✓ (Accept/Aanvaar: to the right/na regs)</p> | (5) |
| <p><u>OPTION 2/OPSIE 2</u> $\Delta p_A = -\Delta p_B$ $p_f - p_i = -(mv_f - mv_i)$ } 1 mark for any/1 punt vir enige $14\,000 - 30\,000$ ✓ = $900v_f - 900(-15)$ ✓ $v_f = 2,78\text{ m}\cdot\text{s}^{-1}$ ✓ east/oos ✓ (Accept/Aanvaar: to the right/na regs)</p> | |

4.2.3

| | |
|--|-----|
| <p><u>OPTION 1/OPSIE 1</u> Slope/Helling = $\frac{\Delta p}{\Delta t} = F_{net}$ ✓ $= \frac{(14\,000 - 30\,000)}{(20,2 - 20,1)}$ ✓ $= -160\,000$ $F_{net} = 160\,000\text{ N}$ ✓</p> | (5) |
| <p><u>OPTION 2/OPSIE 2</u> $F_{net}\Delta t = \Delta p$ ✓ $F_{net}(0,1)$ ✓ = $14\,000 - 30\,000$ ✓ $F_{net} = -160\,000\text{ N}$ $F_{net} = 160\,000\text{ N}$ ✓</p> | |
| <p><u>POSITIVE MARKING FROM QUESTION 4.2.2/POSITIEWE NASIEN VANAF VRAAG 4.2.2</u> <u>OPTION 3/OPSIE 3</u> $F_{net}\Delta t = \Delta p$ ✓ $F_{net}(0,1)$ ✓ = $900[(2,78) - (-15)]$ ✓ $F_{net} = 160\,020\text{ N}$ $F_A = -F_B$ $F_{net} = 160\,020\text{ N}$ ✓</p> | |

| | |
|--|--|
| <p>OPTION 4/OPSIE 4</p> <p>$p = mv$ $14\ 000 = 1\ 500v_f \checkmark$ $v_f = 9,33\ \text{m}\cdot\text{s}^{-1}$</p> | |
| <p>$F_{\text{net}} = \frac{m(v_f - v_i)}{\Delta t} \checkmark = \frac{1500(9,33 - 20)}{0,1} \checkmark$ $= -160\ 050$ $= 160\ 050\ \text{N} \checkmark$</p> | <p>$v_f = v_i + a\Delta t$ $9,33 = 20 + a(0,1)$ $a = -106,7\ \text{m}\cdot\text{s}^{-2}$</p> <p>$F_{\text{net}} = ma \checkmark$ $= 1\ 500(-106,7) \checkmark$ $F_{\text{net}} = -160\ 050\ \text{N}$ $F_{\text{net}} = 160\ 050\ \text{N} \checkmark$</p> |

(4)
[13]

QUESTION 5/VRAAG 5

5.1.1 $E_k/K = \frac{1}{2}mv^2 \checkmark$
 $= \frac{1}{2}(2)(4,95)^2 \checkmark$
 $= 24,50\ \text{J} \checkmark$

(3)

5.1.2 **POSITIVE MARKING FROM QUESTION 5.1.1/POSITIEWE NASIEN VANAF**

5.1.1

OPTION 1/OPSIE 1

$E_{\text{mech before}} = E_{\text{mech after}}$
 $[(E_{\text{mech}})_{\text{bob}} + (E_{\text{mech}})_{\text{block}}]_{\text{before/voor}} = [(E_{\text{mech}})_{\text{Block}} + (E_{\text{mech}})_{\text{bob}}]_{\text{after/na}}$
 $(mgh + \frac{1}{2}mv^2)_{\text{before/voor}} = (mgh + \frac{1}{2}mv^2)_{\text{after/na}}$
 $(5)(9,8)h + 0 + 0 \checkmark = 5(9,8)\frac{1}{4}h + 0 + 24,50 \checkmark$
 $h = 0,67\ \text{m} \checkmark$

Any one/
Enige een ✓

OPTION 2/OPSIE 2

$W_{\text{nc}} = \Delta E_p + \Delta E_k$
 $0 = \Delta E_p + \Delta E_k$
 $-\Delta E_p = \Delta E_k$
 $-[(5)(9,8)(\frac{1}{4}h) - (5)(9,8)h] \checkmark = 24,50 \checkmark$
 $h = 0,67\ \text{m} \checkmark$

Any one/
Enige een ✓

OPTION 3/OPSIE 3

Loss E_p bob = Gain in E_k of block ✓
 $mg(\frac{3}{4}h) = 24,5$
 $(5)(9,8)(\frac{3}{4}h) \checkmark = 24,5 \checkmark$
 $h = 0,67\ \text{m} \checkmark$

(4)

OPTION 4 / OPSIE 4

Before/Voor

$(mgh + \frac{1}{2}mv^2)_{\text{top/bo}} = (mgh + \frac{1}{2}mv^2)_{\text{bottom/onder}}$
 $(5)(9,8)h + 0 = (5)(9,8)h_o + \frac{1}{2}(5)v^2$
 $v_i^2 = 19,6h - 19,6h_o$

After/Na

$(mgh + \frac{1}{2}mv^2)_{\text{bottom/onder}} = (mgh + \frac{1}{2}mv^2)_{\text{top/bo}}$
 $(5)(9,8)h_o + \frac{1}{2}(5)v_f^2 = (5)(9,8)(\frac{1}{4}h) + 0$
 $v_f^2 = 4,9h - 19,6h_o$

$E_{\text{mech/meg before collision/voor botsing}} = E_{\text{mech/meg after collision/na botsing}} \checkmark$

$\frac{1}{2}mv_i^2(\text{bob/skietlood}) + 0 = \frac{1}{2}mv_f^2(\text{bob/skietlood}) + \frac{1}{2}mv^2(\text{block/blok})$
 $\frac{1}{2}(5)(19,6h - 19,6h_o) \checkmark = \frac{1}{2}(5)(4,9h - 19,6h_o) + 24,5 \checkmark$
 $h = 0,67\ \text{m} \checkmark$

- 5.2 The net/total work done on an object is equal ✓ to the change in the object's kinetic energy ✓
Die netto/totale arbeid op 'n voorwerp verrig is gelyk aan die verandering in die kinetiese energie van die voorwerp.

OR/OF

The work done on an object by a resultant/net force is equal to the change in the object's kinetic energy.

Die arbeid verrig op 'n voorwerp deur 'n resulterende/netto krag is gelyk aan die voorwerp se verandering in kinetiese energie.

(2)

- 5.3

OPTION 1/OPSIE 1

$$W_{\text{net}} = \Delta E_K \checkmark$$

$$W_f + mg\Delta y \cos\theta = \frac{1}{2}m(v_f^2 - v_i^2)$$

$$W_f + (2)(9,8)(0,5)\cos 180^\circ \checkmark = \frac{1}{2}(2)(2^2 - 4,95^2) \checkmark$$

$$W_f = -10,7 \text{ J} \checkmark$$

OPTION 2/OPSIE 2

$$W_{\text{nc}} = \Delta E_K + \Delta U \checkmark$$

$$W_{\text{nc}} = \Delta E_K + \Delta E_P \checkmark$$

$$W_f = \frac{1}{2}(2)(2^2 - 4,95^2) \checkmark + (2)(9,8)(0,5-0) \checkmark$$

$$= -10,7 \text{ J} \checkmark$$

(4)

[13]

QUESTION 6/VRAAG 6

- 6.1.1 It is the (apparent) change in frequency (or pitch) of the sound (detected by a listener) ✓ because the sound source and the listener have different velocities relative to the medium of sound propagation. ✓
Dit is die verandering in frekwensie (of toonhoogte) van die klank (waargeneem deur 'n luisteraar) omdat die klankbron en die luisteraar verskillende snelhede relatief tot die medium van klankvoortplanting het.

OR/OF

An (apparent) change in (observed/detected) frequency (pitch), (wavelength) ✓ as a result of the relative motion between a source and an observer ✓ (listener).

'n Skynbare verandering in (waargenome) frekwensie (toonhoogte), (golflengte) as gevolg van die relatiewe beweging tussen die bron en 'n waarnemer/luisteraar.

(2)

- 6.1.2 $v = f\lambda \checkmark$
 $340 = f(0,28) \checkmark$
 $f_s = 1\,214,29 \text{ Hz} \checkmark$

(3)

6.1.3 **POSITIVE MARKING FROM QUESTION 6.1.2/POSITIEWE NASIEN VANAF VRAAG 6.1.2**

$$f_L = \frac{v \pm v_L}{v \pm v_s} f_s \text{ OR/OF } f_L = \frac{v \pm v_L}{v \pm v_s} \times \frac{v}{\lambda_s} \text{ OR/OF } f_L = \frac{v}{v - v_s} f_s \text{ OR/OF } f_L = \frac{f_s}{1 - \frac{v_s}{v}} \checkmark$$

$$f_L = \left(\frac{340}{340 - 30}\right) 1214,29 \checkmark \text{ OR/OF } f_L = \left(\frac{340}{340 - 30}\right) \times \frac{340}{0,28} \text{ OR/OF } f_L = \frac{1214,29}{1 - \frac{30}{340}}$$

$$= 1\,331,80 \text{ Hz} \checkmark \quad (1\,331,80 \text{ Hz} - 1\,335,72 \text{ Hz}) \quad (5)$$

6.1.4 Decreases/Verlaag ✓ (1)

6.2 The spectral lines of the star are/should be shifted towards the lower frequency ✓ end, which is the red end (red shift) of the spectrum. ✓

Die spektraallyne van die van die ster is verskuif na die laer frekwensie ent, wat die rooi ent van die spektrum is.

(2)
[13]

QUESTION 7/VRAAG 7

7.1.1 The (magnitude of the) electrostatic force exerted by one (point) charge on another is directly proportional to the product of the charges ✓ and inversely proportional to the square of the distance between their (centres) them. ✓

Die (grootte) van die elektrostatiese krag wat een (punt) lading op 'n ander uitoefen, is direk eweredig aan die produk van die ladings en omgekeerd eweredig aan die kwadraat van die afstand tussen hul middelpunte.

(2)

7.1.2 F_E /Electrostatic force/Elektrostatiese krag ✓ (1)

7.1.3 The electrostatic force is inversely proportional to the square of the distance between the charges ✓

Die elektrostatiese krag is omgekeerd eweredig aan die kwadraat van die afstand tussen die ladings

OR/OF

The electrostatic force is directly proportional to the inverse of the square of the distance between the charged spheres (charges). ✓

Die elektrostatiese krag is direk eweredig aan omgekeerde van die kwadraat van die afstand tussen die gelaaiede sfere (ladings).

OR/OF

$$F \propto \frac{1}{r^2} \checkmark$$

OR/OF

They are inversely proportional to each other /Hulle is omgekeerd eweredig aan mekaar

(1)

7.1.4

| | |
|--|---|
| <p>OPTION 1/OPSIE 1</p> <p>Slope/Helling = $\frac{\Delta F_E}{\Delta \frac{1}{r^2}} = \frac{(0,027 - 0)}{(5,6 - 0)}$ ✓</p> <p style="margin-left: 40px;">$= 4,82 \times 10^{-3} \text{ N} \cdot \text{m}^2 \quad (4,76 \times 10^{-3} - 5 \times 10^{-3})$</p> <p>Slope/Helling = $F_E r^2 = kQ_1 Q_2 = kQ^2$ ✓</p> <p>$4,82 \times 10^{-3} = \frac{9 \times 10^9 Q^2}{()}$ ✓</p> <p>$\therefore Q = 7,32 \times 10^{-7} \text{ C}$ ✓</p> <p>OPTION 2/OPSIE 2</p> <p>Accept any pair of points on the line/Aanvaar enige paar punte op die lyn</p> <p>$F = \frac{kQ_1 Q_2}{r^2}$ ✓</p> <p>$() = \frac{(9 \times 10^9) Q^2}{()}$ ✓ ✓</p> <p>$Q = 7,32 \times 10^{-7} \text{ C}$ ✓ $(7,32 \times 10^{-7} - 7,45 \times 10^{-7} \text{ C})$</p> <p>Examples/Voorbeelde</p> <p>$(0,005) = \frac{(9 \times 10^9) Q^2}{(1)}$ ✓ ✓</p> <p>$Q = 7,45 \times 10^{-7} \text{ C}$ ✓</p> <p>$(0,027) = \frac{(9 \times 10^9) Q^2}{(\frac{1}{5,6})}$ ✓ ✓</p> <p>$Q = 7,32 \times 10^{-7} \text{ C}$ ✓</p> | <p>1 mark for using slope/ 1 punt vir die gebruik van helling</p> |
|--|---|

(6)

7.2.1

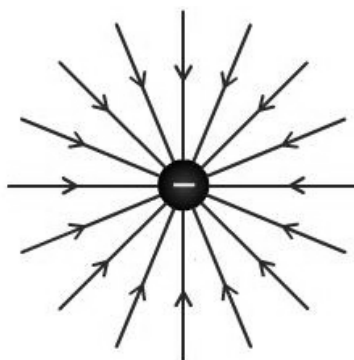

| Criteria for drawing electric field: Kriteria vir teken van elektriese veld: | Marks/Punte |
|---|--------------------|
| Direction / Rigting | ✓ |
| Field lines radially inward/Veldlyne radiaal inwaarts | ✓ |

7.2.2

$$E = \frac{kQ}{r^2} \checkmark$$

Take right as positive/Neem regs as positief

$$E_{PA} = \frac{(9 \times 10^9)(0,75 \times 10^{-6})}{(0,09)^2} \checkmark$$

$$= 8,33 \times 10^5 \text{ N}\cdot\text{C}^{-1} \text{ to the left/na links}$$

$$E_{PB} = \frac{(9 \times 10^9)(0,8 \times 10^{-6})}{(0,03)^2} \checkmark$$

$$= 8 \times 10^6 \text{ N}\cdot\text{C}^{-1} \text{ to the left/na links}$$

$$E_{\text{net}} = E_{PA} + E_{PB}$$

$$= [-8,33 \times 10^5 + (-8 \times 10^6)] \checkmark$$

$$= -8,83 \times 10^6$$

$$= 8,83 \times 10^6 \text{ N}\cdot\text{C}^{-1} \checkmark$$

1 mark for the addition of same signs/
1 punt vir optelling van dieselfde tekens

Take left as positive/Neem links as positief

$$E_{PA} = \frac{(9 \times 10^9)(0,75 \times 10^{-6})}{(0,09)^2} \checkmark$$

$$= 8,33 \times 10^5 \text{ N}\cdot\text{C}^{-1} \text{ to the left/na links}$$

$$E_{PB} = \frac{(9 \times 10^9)(0,8 \times 10^{-6})}{(0,03)^2} \checkmark$$

$$= 8 \times 10^6 \text{ N}\cdot\text{C}^{-1} \text{ to the left/na links}$$

$$E_{\text{net}} = E_{PA} + E_{PB}$$

$$= (8,33 \times 10^5 + 8 \times 10^6) \checkmark$$

$$= 8,83 \times 10^6 \text{ N}\cdot\text{C}^{-1} \checkmark$$

1 mark for the addition of same signs/
1 punt vir optelling van dieselfde tekens

(5)
[17]

QUESTION 8/VRAAG 8

8.1.1 (Maximum) energy provided (work done) by a battery per coulomb/unit charge passing through it ✓✓ / *Energie verskaf (arbeid verrig) deur 'n battery per coulomb/eenheid lading wat daardeur vloei.* (2)

8.1.2 12 (V)✓ (1)

8.1.3 0 (V) / Zero/nul ✓ (1)

8.1.4 $\epsilon = I(R + r)$ } ✓
 $\epsilon = V_{\text{ext}} + V_{\text{int}}$ }
 $12 = 11,7 + Ir$
 $0,3 = I_{\text{tot}}(0,2)$ ✓
 $I_{\text{tot}} = 1,5 \text{ A}$ ✓

OR/OF

$V = IR$ ✓ (Accept/Aanvaar: $V_{\text{lost}} = Ir$)

$0,3 = I_{\text{tot}}(0,2)$ ✓

$I_{\text{tot}} = 1,5 \text{ A}$ ✓

(3)

8.1.5

| OPTION 1/OPSIE 1 | OPTION 2/OPSIE 2 |
|--|---|
| $\left. \begin{aligned} \frac{1}{R_{\parallel}} &= \frac{1}{R_1} + \frac{1}{R_2} \\ \frac{1}{R} &= \frac{1}{10} + \frac{1}{15} \end{aligned} \right\} \begin{array}{l} \checkmark \text{ Any one} \\ \text{Enigeen} \end{array}$ $R = 6 \Omega$ ✓ | $\left. \begin{aligned} R_{\parallel} &= \frac{R_1 R_2}{R_1 + R_2} \\ &= \frac{(10)(15)}{10 + 15} \end{aligned} \right\} \begin{array}{l} \checkmark \text{ Any one} \\ \text{Enigeen} \end{array}$ $= 6 \Omega$ ✓ |

(2)

8.1.6

| POSITIVE MARKING FROM QUESTIONS 8.1.4 AND 8.1.5/POSITIEWE NASIEN VANAF VRAE 8.1.4 EN 8.1.5 | |
|---|--|
| OPTION 1/OPSIE 1 | OR/OF |
| $V = IR$ ✓ $11,7 \checkmark = \underline{1,5(6 + R)}$ ✓ $R = 1,8 \Omega$ ✓ | $V = IR$ ✓ $11,7 = 1,5R$ ✓ $R = 7,8 \Omega$ \downarrow $R_R = 7,8 - 6$ ✓ $= 1,8 \Omega$ ✓ |

| |
|--|
| <p>OPTION 2/OPSIE 2</p> $\varepsilon = I(R + r) \checkmark$ $12 = 1,5(R + 0,2) \checkmark$ $R = 7,8 \Omega$ <p style="text-align: center;">↓</p> $R_R = 7,8 - 6 \checkmark$ $= 1,8 \Omega \checkmark$ |
| <p>OPTION 3/OPSIE 3</p> $V_{ } = IR_{ }$ $= (6)(1,5) \checkmark$ $= 9 \text{ V}$ $V_R = IR \checkmark$ $(11,7 - 9) = (1,5)R \checkmark$ $R = 1,8 \Omega \checkmark$ |

(4)

8.2.1

| |
|--|
| $P_{\text{avelgemid}} = Fv_{\text{avelgemid}} \checkmark = mg(v_{\text{avelgemid}})$ $= (0,35)(9,8)(0,4) \checkmark$ $= 1,37 \text{ W} \checkmark$ <p>OR/OF</p> $P = \frac{W_{\text{nc}}}{\Delta t} \checkmark = \frac{\Delta E_k + \Delta E_p}{\Delta t} = \frac{0 + (0,35)(9,8)(0,4 - 0)}{1} \checkmark = 1,37 \text{ W} \checkmark$ <p>OR/OF</p> $P = \frac{W}{\Delta t} \checkmark = \frac{E_p}{\Delta t} = \frac{(0,35)(9,8)(0,4)}{1} \checkmark = 1,37 \text{ W} \checkmark$ |
|--|

(3)

8.2.2

| | |
|--|---|
| <p>POSITIVE MARKING FROM QUESTION 8.2.1/POSITIEWE NASIEN VANAF VRAAG 8.2.1</p> | |
| <p>OPTION 1/OPSIE 1</p> $P = VI$ $1,37 = (3)I \checkmark$ $I = 0,46 \text{ A}$ $\varepsilon = V_{\text{ext}} + V_{\text{int}}$ $= V_T + V_X + V_{\text{int}}$ $12 = V_T + 3 + (0,2)(0,46) \checkmark$ $V_T = 8,91 \text{ V}$ $V_T = IR_T$ $8,91 = (0,46)R_T \checkmark$ $R_T = 19,37 \Omega \checkmark$ | <p>OPTION 2/OPSIE 2</p> $P = \frac{V^2}{R}$ $1,37 = \frac{3^2}{R} \checkmark$ $R = 6,57 \Omega$ $P = VI$ $1,37 = (3)I \checkmark$ $I = 0,46 \text{ A}$ $\varepsilon = I(R + r)$ $12 = 0,46(6,57 + R_T + 0,2) \checkmark$ $R_T = 19,38 \Omega \checkmark$ |

OPTION 3/OPSIE 3

$$P = VI \checkmark$$

$$1,37 = (3)I \checkmark$$

$$I = 0,46 \text{ A}$$

$$P_{\text{tot}} = P_r + P_{\text{motor}} + P_T$$

$$(12)(0,46) \checkmark = (0,46)^2(0,2) + 1,37 + (0,46)^2 R_T \checkmark$$

$$R_T = 19,41 \Omega \checkmark$$

OR/OF

$$P = VI \checkmark$$

$$1,37 = (3)I \checkmark$$

$$I = 0,46 \text{ A}$$

$$P_{\text{tot}} = P_r + P_{\text{motor}} + P_T$$

$$(12)(0,46) = (0,46)^2(0,2) + 1,37 + P_T \checkmark$$

$$P_T = 4,07 \text{ W}$$

$$P = I^2 R$$

$$4,07 = (0,46)^2 R_T \checkmark$$

$$R_T = 19,49 \Omega \checkmark$$

OPTION 4/OPSIE 4

$$P = VI$$

$$1,37 = (3)I \checkmark$$

$$I = 0,46 \text{ A}$$

✓ Any one
Enigeen

$$\epsilon = I(R + r)$$

$$12 = (0,46)(R + 0,2) \checkmark$$

$$R = 25,87 \Omega$$

$$V = IR$$

$$3 = (0,46)R \checkmark$$

$$R = 6,52 \Omega$$

$$R_T = 25,87 - 6,52$$

$$= 19,35 \Omega \checkmark$$

$$P = I^2 R$$

$$1,37 = (0,46)^2 R \checkmark$$

$$R = 6,47 \Omega$$

$$R_T = 25,87 - 6,47$$

$$= 19,4 \Omega \checkmark$$

$$P_{\text{motor}} = \frac{V^2}{R}$$

$$1,37 = \frac{3^2}{R} \checkmark$$

$$R = 6,56 \Omega$$

$$R_T = 25,87 - 6,56$$

$$= 19,31 \Omega \checkmark$$

(5)
[21]

QUESTION 9/VRAAG 9

9.1.1 DC/GS-generator ✓

Uses split ring/commutator/*Gebruik spleetring/kommutator* ✓

(2)

9.1.2

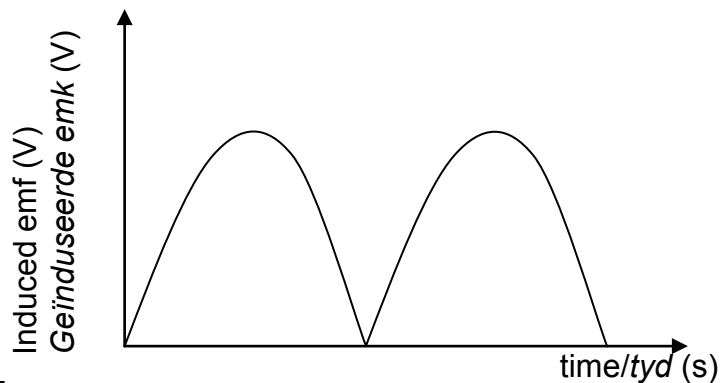

OR/OF

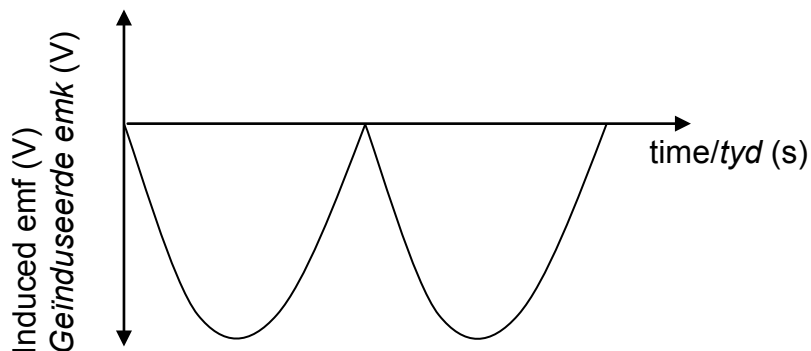

(2)

9.2.1

| | |
|--|---|
| <p>OPTION 1/OPSIE 1</p> $V_{\text{rms/wgk}} = \frac{V_{\text{max/maks}}}{\sqrt{2}}$ $P_{\text{ave/gem}} = V_{\text{rms/wgk}} I_{\text{rms/wgk}} \checkmark$ $800 = \frac{340}{\sqrt{2}} (I_{\text{rms/wgk}}) \checkmark$ <hr/> $I_{\text{rms/wgk}} = 3,33 \text{ A} \checkmark$ | <p>OR/OF</p> $V_{\text{rms/wgk}} = \frac{V_{\text{max/maks}}}{\sqrt{2}} = \frac{340}{\sqrt{2}} = 240,416$ $P_{\text{ave/gem}} = V_{\text{rms/wgk}} I_{\text{rms/wgk}} \checkmark$ $800 = I_{\text{rms/wgk}} (240,416) \checkmark$ $I_{\text{rms/wgk}} = 3,33 \text{ A} \checkmark$ |
|--|---|

OPTION 2/OPSIE 2

$$P_{\text{ave/gem}} = \left(\frac{V_{\text{rms/wgk}}^2}{R} \right) = \frac{(V_{\text{max/maks}}^2)}{(2)(R)}$$

✓ { $800 = \frac{(340)^2}{(\sqrt{2})^2(R)}$

$R = 72,25 \Omega$

$$P_{\text{ave/gem}} = I_{\text{rms/wgk}}^2 R$$

$$800 = I_{\text{rms/wgk}}^2 (72,25) \checkmark$$

$$I_{\text{rms/wgk}} = 3,33 \text{ A} \checkmark$$

$V_{\text{rms/wgk}} = I_{\text{rms/wgk}} R$

$I_{\text{rms/wgk}} = \frac{240,416}{72,25} \checkmark$

$= 3,33 \text{ A} \checkmark$

(3)

9.2.2 **POSITIVE MARKING FROM QUESTION 9.2.1**
POSITIEWE NASIEN VANAF VRAAG 9.2.1
OPTION 1/OPSIE 1

$P_{\text{ave/gemid}} = V_{\text{rms/wgk}} I_{\text{rms/wgk}} \checkmark$

for the kettle/vir die ketel:

$$2000 = \frac{340}{\sqrt{2}} (I_{\text{rms/wgk}}) \checkmark$$

$I_{\text{rms/wgk}} = 8,32 \text{ A}$

$I_{\text{tot}} = (8,32 + 3,33) \checkmark$

$= 11,65 \text{ A} \checkmark$

OPTION 2/OPSIE 2

$$P_{\text{ave/gemid}} = \left(\frac{V_{\text{rms/wgk}}^2}{R} \right) \checkmark = \frac{(V_{\text{max/maks}}^2)}{(2)(R)}$$

$800 = \frac{(340)^2}{(\sqrt{2})^2(R)} \checkmark$

$R = 72,25 \Omega$

$2000 = \frac{(340)^2}{(\sqrt{2})^2(R_{2000})}$

$R = 28,9 \Omega$

$$R = \frac{(28,9)(72,25)}{(28,9 + 72,25)} = 20,64 \Omega$$

$\frac{1}{R} = \frac{1}{R_1} + \frac{1}{R_2}$

$V_{\text{rms/wgk}} = I_{\text{rms/wgk}} R$

$240,42 = I_{\text{rms/wgk}} (20,64) \checkmark$

$I_{\text{rms/wgk}} = 11,65 \text{ A} \checkmark$

OPTION 3/OPSIE 3

$$P_{\text{ave/gemid}} = V_{\text{rms/wgk}} I_{\text{rms/wgk}} \checkmark = \frac{V_{\text{max/maks}} I_{\text{max/maks}}}{2}$$

$$2\,800 \checkmark = \frac{(340) I_{\text{max/maks}} \checkmark}{2}$$

$$I_{\text{max/maks}} = 16,47 \text{ A}$$

$$I_{\text{rms}} = \frac{I_{\text{max/maks}}}{\sqrt{2}} = \frac{16,47}{\sqrt{2}}$$

$$I_{\text{rms/wgk}} = 11,65 \text{ A} \checkmark$$

OPTION 4/OPSIE 4

$$P_{\text{ave/gemid}} = V_{\text{rms/wgk}} I_{\text{rms/wgk}} \checkmark$$

$$2\,800 \checkmark = \frac{340}{\sqrt{2}} I_{\text{rms/wgk}} \checkmark$$

$$I_{\text{rms/wgk}} = 11,65 \text{ A} \checkmark$$

OPTION 5/OPSIE 5

$$P_T : P_K$$

$$800 : 2\,000 \checkmark$$

$$1 : 2,5$$

$$I_T : I_K$$

$$3,33 : 8,325 \checkmark$$

$$I_{\text{rms}} = 3,33 + 8,325 \checkmark \\ = 11,66 \text{ A} \checkmark$$

(4)
[11]

QUESTION 10/VRAAG 10

- 10.1.1 The minimum frequency (of a photon/light) needed✓ to emit electrons from (the surface of) a metal. (substance) ✓
Die minimum frekwensie (van 'n foton/lic) benodig om elektrone vanaf die (oppervlakte van)'n metaal (stof) vry te stel

OR/OF

- The frequency (of a photon/light) needed✓ to emit electrons from (the surface of) a metal. (substance) with zero kinetic energy✓
Die frekwensie (van 'n foton/lic) benodig om elektrone vanaf die (oppervlakte van)'n metaal (stof) met nul/geen kinetiese energie vry te stel

(2)

10.1.2 Silver/Silwer✓

Threshold/cutoff frequency (of Ag) is higher/Drumpel/afsnryfrekwensie (van Ag) is hoër✓

$$W_o \propto f_o / W_o = hf_o \checkmark$$

OR/OF

To eject electrons with the same kinetic energy from each metal, light of a higher frequency/energy is required for silver. ✓ Since $E = W_o + E_{k(max)}$ (and E_k is constant), the higher the frequency/energy of the photon/light required, the greater is the work function/ W_o .✓

Om elektrone met dieselfde kinetiese energie van elke metal vry te stel, is lig van hoër frekwensie benodig vir silwer. Aangesien $E = W_o + E_{k(max)}$ (en $E_{k(max)}$ is konstant) word fotone/lig van hoër frekwensie/energie benodig, dus is arbeidsfunksie hoër

(3)

10.1.3 Planck's constant /Planck se konstante ✓

(1)

10.1.4 Sodium/Natrium✓

(1)

10.2.1 Energy radiated per second by the blue light /Energie per sekonde uitgestraal

deur die bloulig = $(\frac{5}{100})(60 \times 10^{-3}) \checkmark = 3 \times 10^{-3} \text{ J}\cdot\text{s}^{-1}$

$$E_{\text{photon/foton}} = \frac{hc}{\lambda} \checkmark$$
$$= \frac{(6,63 \times 10^{-34})(3 \times 10^8)}{470 \times 10^{-9}} \checkmark$$
$$= 4,232 \times 10^{-19} \text{ J}$$

Total number of photons incident per second/Totale aantal fotone wat per

sekonde inval = $\frac{3 \times 10^{-3}}{4,232 \times 10^{-19}} \checkmark$

$$= 7,09 \times 10^{15} \checkmark$$

(5)

10.2.2 **POSITIVE MARKING FROM QUESTION 10.2.1**
POSITIEWE NASIEN VANAF VRAAG 10.2.1

$7,09 \times 10^{15}$ (electrons per second/elektron per sekonde) ✓

OR/OF

Same number as that calculated in Question 10.2.1 above/Dieselfde as die in Vraag 10.2.1 hierbo bereken

(1)

[13]

TOTAL/TOTAAL: 150